

Short manual
External venetian blinds

2019





All short manuals for download



[↓ External venetian blinds](#)



[↓ Awnings](#)



[↓ Facade awnings](#)

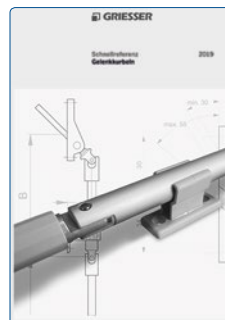

[↓ Articulated cranks](#)



[↓ Window shutters](#)



[↓ Connection technique](#)

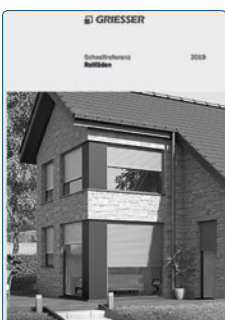

[↓ Rolling shutters](#)



[↓ Covers](#)



External venetian blinds

Table of contents

Metalunic® V Metalunic® V Sinus	5
Grinotex® III Grinotex® III Sinus	33
Lamisol® III	75
Lamisol® III System	121
Lamisol® III Vento	151
Aluflex®	179
Solomatic® II	239
Solomatic® II System	303
Annex	333
Index	339

 The information and values given refer to our products in their standard version according to the brochure and intended use/application.

Metalunic® V | Metalunic® V Sinus

Limit dimensions	6
Built-in system	7
Built-in system with cover	7
Header dimensions Heights of package	8
Slat profiles	9
Darkening	10
Guide rail	11
Sections Details	12
Sections for crank drive (MBMA)	13
Guide rail installation (principle)	14
Guide rail fastenings (principle)	16
Guide extension and facet	21
Guide rail cut-outs in windowsill area	22
Fastening points	24
Connected systems	28
Technical data of motors	30



Limit dimensions

Single blind

Operation	Width min. (bk)	Width ¹ max. (bk)	Height min. (hl)	Height max. (hl)	Surface ² max. [m ²]
Crank drive	500	2800	440	4000	6.5
Motor drive	700				8

Connected systems

Operation	Width ¹ max. (bk)	Height max. (hl)	Blinds max.	Blinds per system	Surface ² max. [m ²]
Crank drive	8400	4000	3	2	5
Motor drive			2	2	4.8

¹ For buildings and high-rise structures, which are exposed to high winds, this maximum value should be decreased as required. Also see wind classes data sheet.

² If crank drive is in slat area: maximum surface area and crank position available on request.

Inclined installation

Metalunic® V Sinus

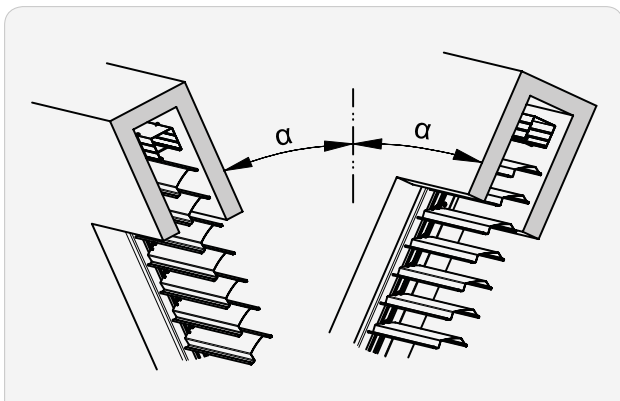

Bracket from the vertical [α]	Width max. (bk)
max. 25°	1800

⚠ Reduce maximum loading with inclined installation by 20 %.

i Protect blinds angled towards the outside from the effects of weathering (snow, ice).

Built-in system

Vertical section: Metalunic® V

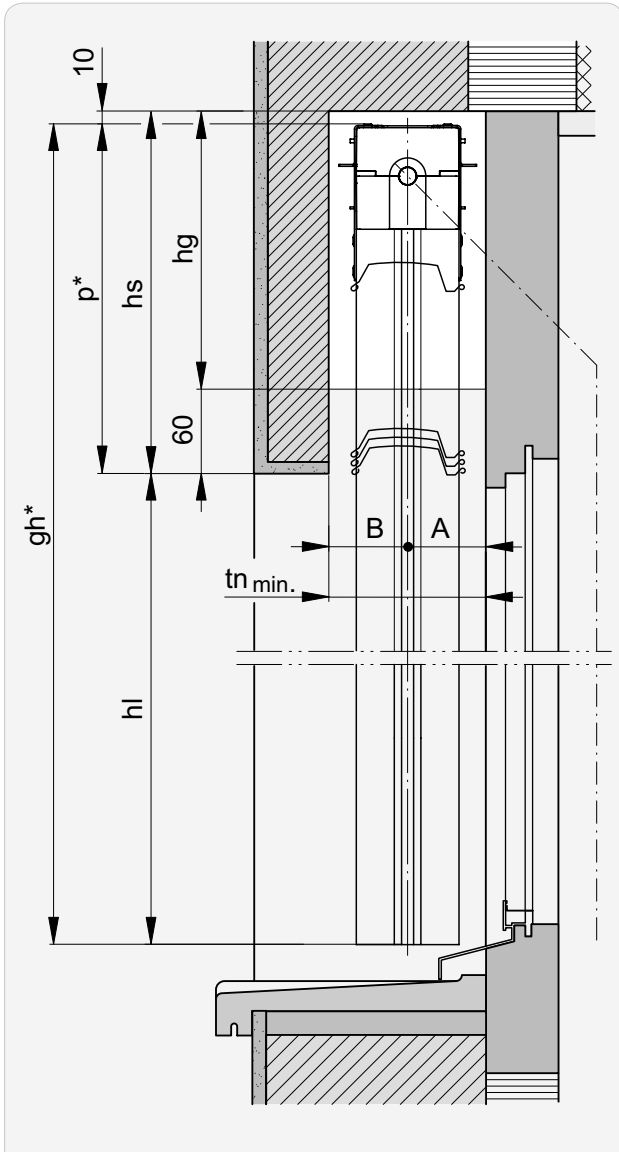

Built-in system with cover

Vertical section: Metalunic® V Sinus

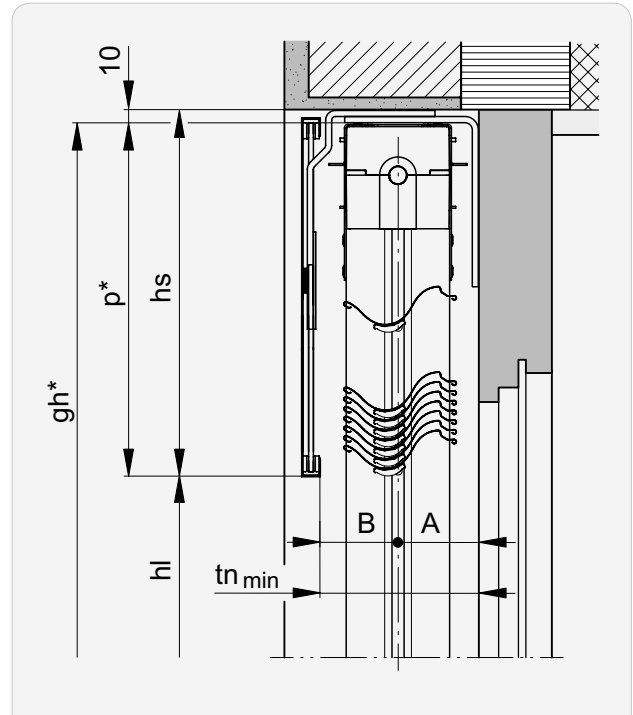

i * Due to the split arrangement of the chain, **gh** and /or **p** can be reduced by up to 15 mm compared to the ordering dimensions.

Horizontal section

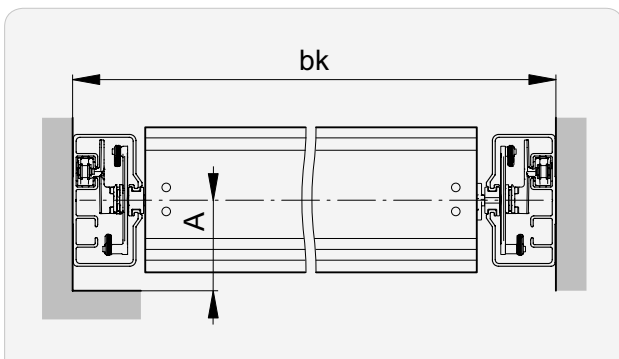

Header dimensions | Heights of package

Metalunic® V

hl →l	P min.	hs ¹	hl →l	P min.	hs ¹
1100	260	270	2550	410	420
1150	265	275	2600	420	430
1200	270	280	2700	425	435
1250	275	285	2750	435	445
1350	285	295	2850	440	450
1400	290	300	2900	450	460
1450	295	305	3000	460	470
1500	300	310	3050	465	475
1550	305	315	3100	470	480
1650	315	325	3150	475	485
1700	320	330	3200	480	490
1800	330	340	3300	490	500
1850	340	350	3350	500	510
1950	345	355	3450	505	515
2000	355	365	3500	515	525
2100	360	370	3600	520	530
2150	370	380	3700	530	540
2250	380	390	3750	540	550
2300	385	395	3850	545	555
2400	395	405	3900	555	565
2450	400	410	3950	560	570
2500	405	415	4000	565	575

tn min.	A	B
120*	60	60

Metalunic® V Sinus

hl →l	P min.	hs ¹	hl →l	P min.	hs ¹
1150	260	270	2550	405	415
1200	265	275	2600	415	425
1300	270	280	2650	420	430
1350	280	290	2700	425	435
1450	290	300	2800	430	440
1500	295	305	2850	440	450
1550	300	310	2900	445	455
1600	305	315	2950	450	460
1650	310	320	3000	455	465
1750	320	330	3100	465	475
1800	330	340	3200	470	480
1900	335	345	3250	480	490
1950	345	355	3350	490	500
2050	350	360	3400	495	505
2100	360	370	3500	505	515
2150	365	375	3550	510	520
2200	370	380	3650	520	530
2250	375	385	3700	530	540
2300	380	390	3800	535	545
2350	385	395	3850	545	555
2400	390	400	3950	550	560
2500	400	410	4000	560	570

tn min.	A	B
120*	60	60

¹ With gearbox in slat area: **hs + 20**.

² **Depending on the angle** of the gearbox output, **tn min.** should be **increased by 5 ... 10 mm** in this area.

* + possible addition for protruding weatherboard or doorknobs.

i Header dimensions are approximate values which may exhibit **negative or positive deviations** depending on the technical circumstances. **A dimensional tolerance of ±5 mm** is observed for the header height.

Slat profiles

Metalunic® V

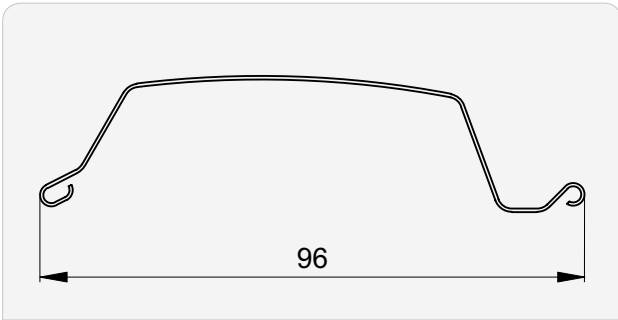

Metalunic® V Sinus

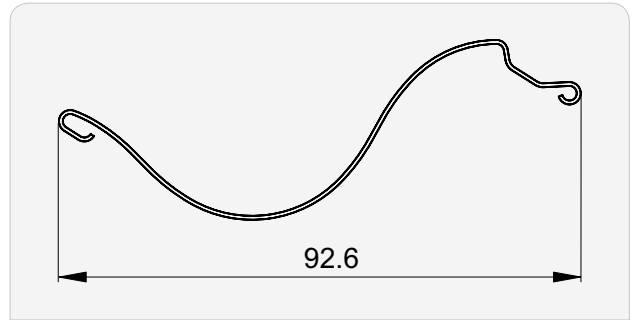

Darkening

Horizontal: Darkening profile

The following measures make it possible to achieve ideal shading results:

Locate the guides outside of the clear dimension of the window glass, if possible



Continuous fixing bracket

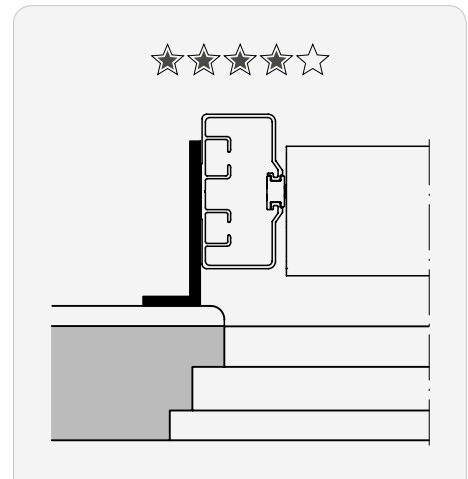

Vertical

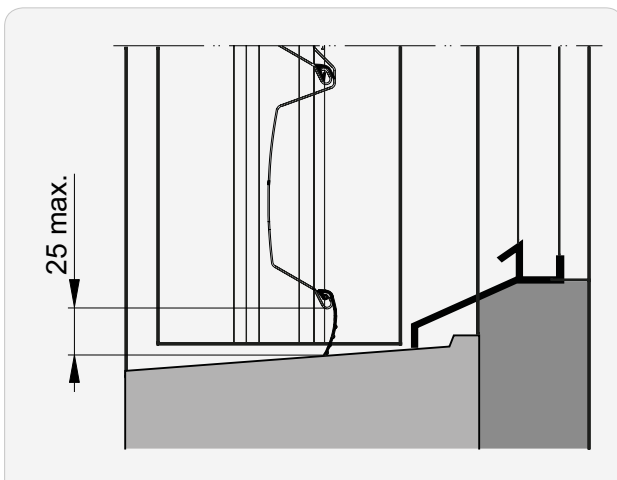

Guide rail

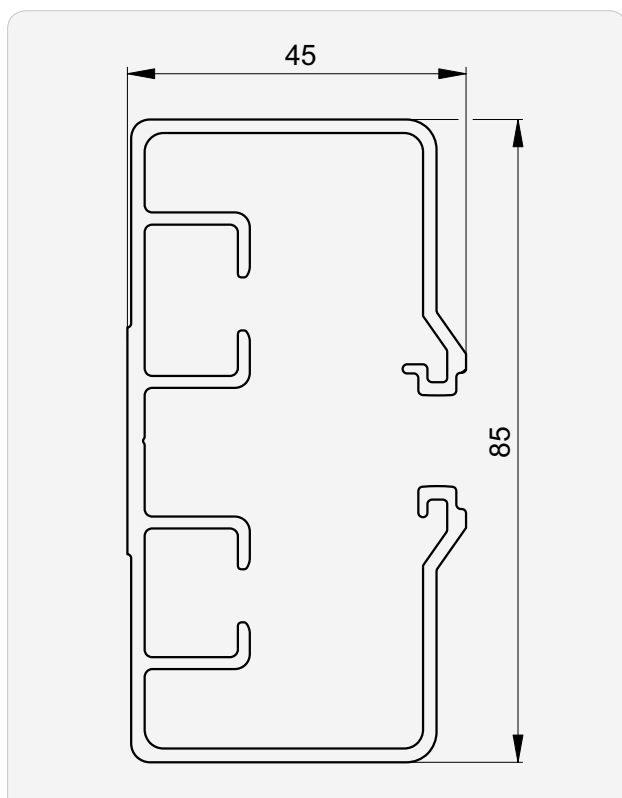

➔ Distance between guides FD	28	➔ Guide rail fastenings	16
➔ Fastening points	24	➔ Guide rail cut-outs in windowsill area.....	22
➔ Guide extension and facet.....	21	➔ Integrated guides	15

Sections | Details

Detail for bottom: Metalunic® V

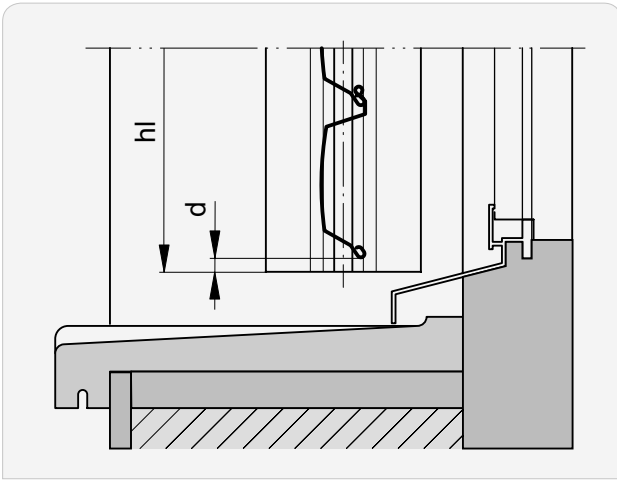

Detail for bottom: Metalunic® V Sinus

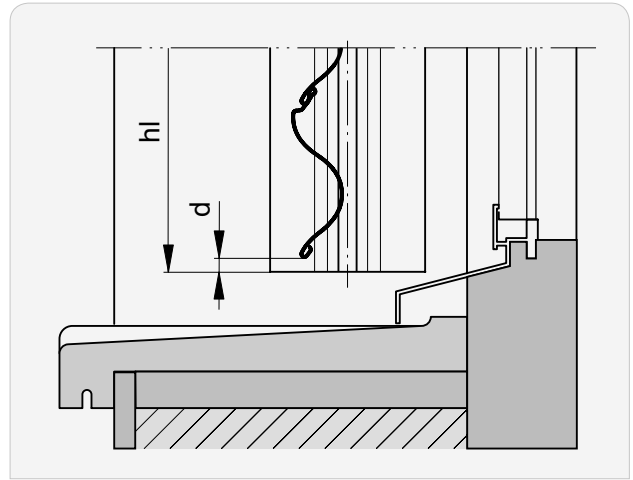

d (d-dimension)

6 ± 5

i **d-dimension** may vary with different blind dimensions.

Sections for crank drive (MBMA)

outside bk

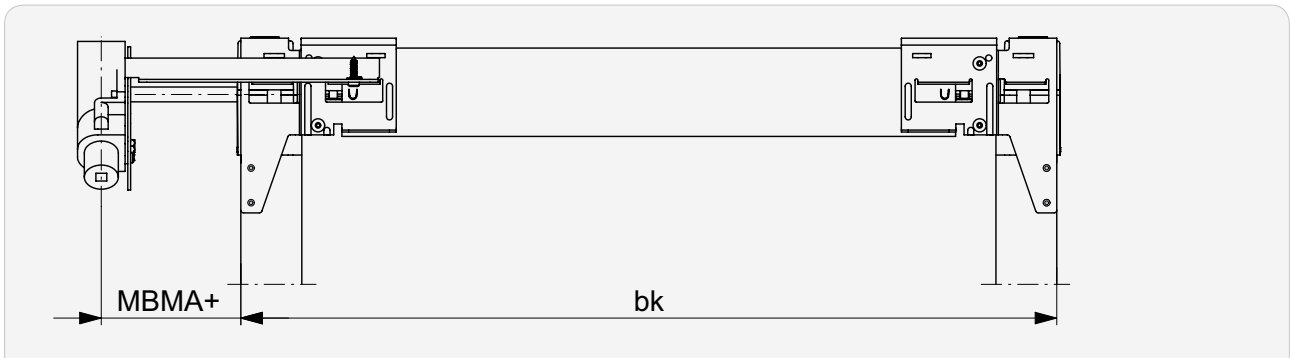

within bk

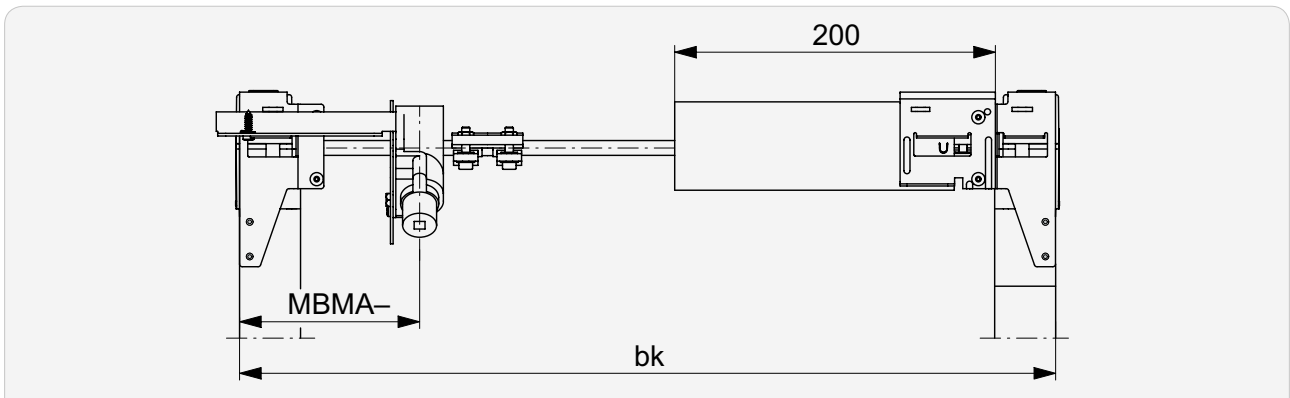

Gearbox inside housing

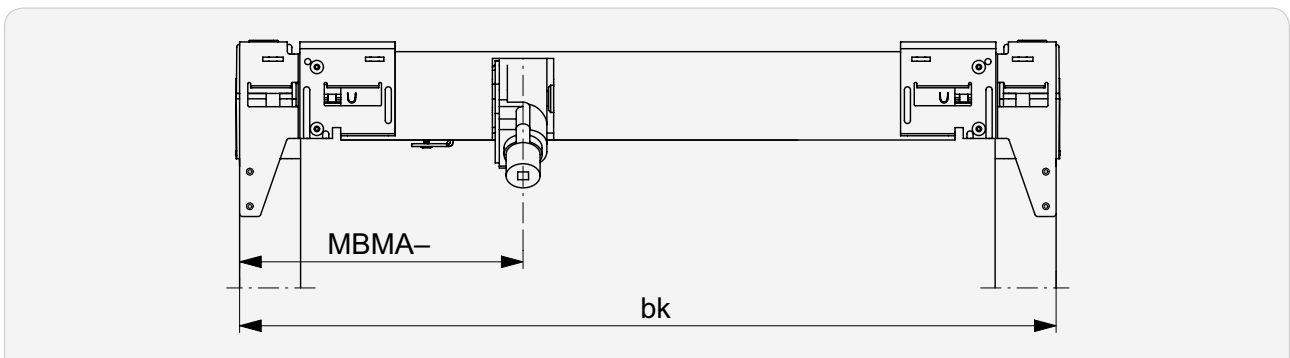

MBMA+

25 ... 160

* Gearbox inside housing

MBMA-

90 ... 210

211 ... (bk/2)*

Guide rail installation (principle)

Guides attached (to soffit) | Type A

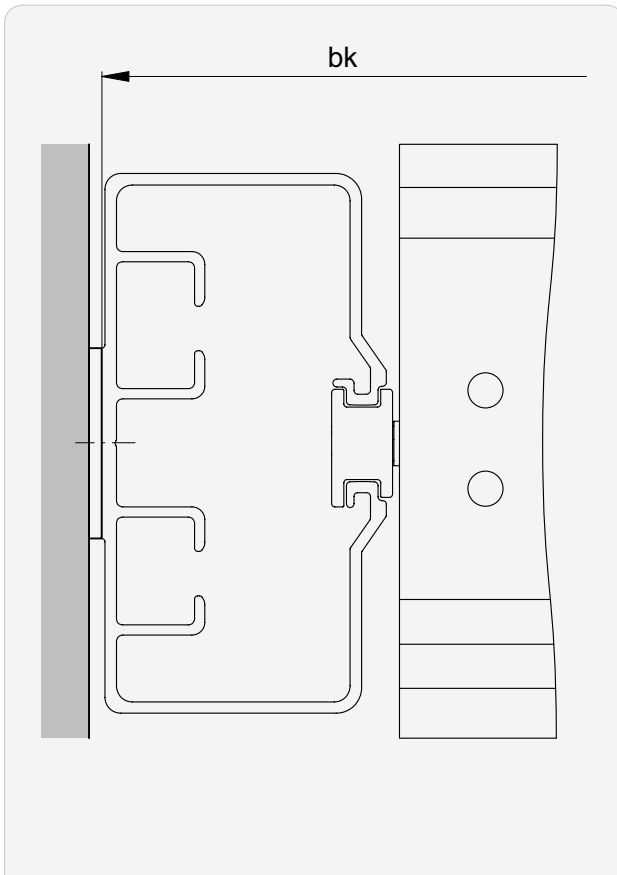

Guides suspended

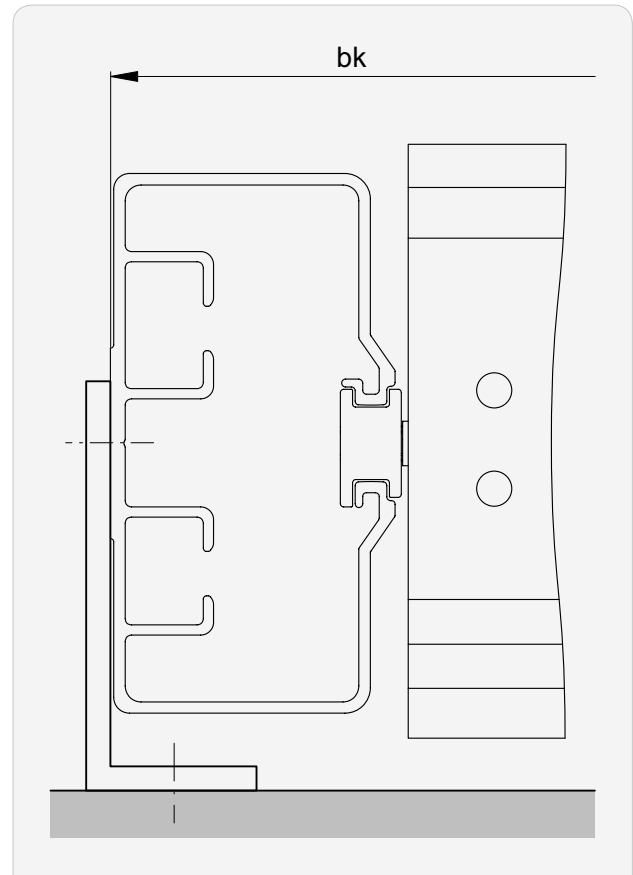

i Observe possible guide rail spacer for **bk**.
Standard: 2 mm

►► Guide rail installation (principle)

Guides recessed

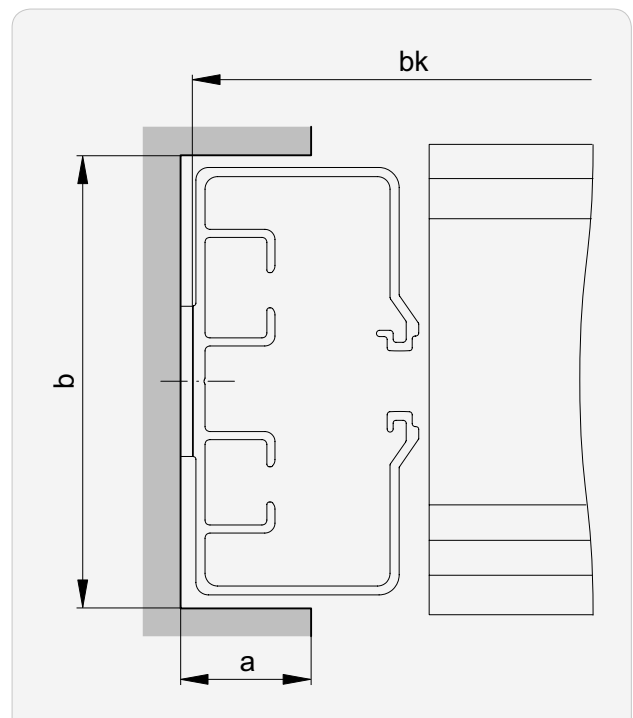
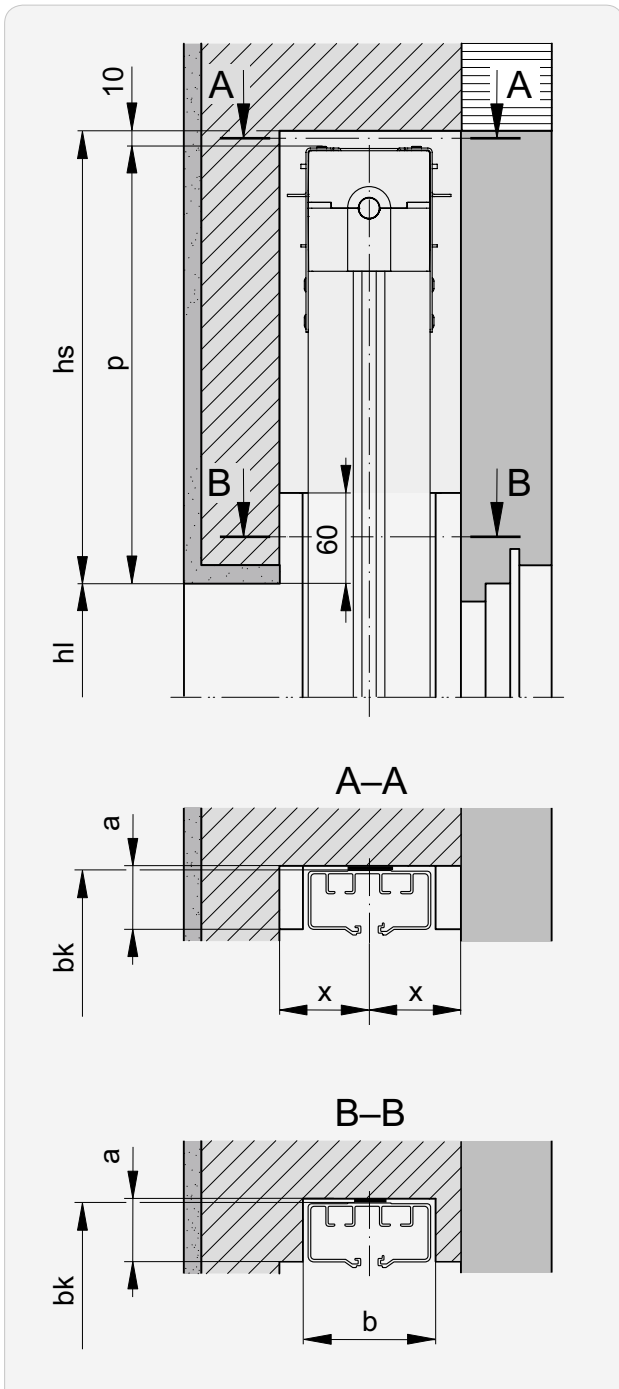

Version	x min.
Crank drive	60
Motor drive	50

a	b
≤40	≥90

Guide rail fastenings (principle)

Overview

														Type	
A	B	Bd	C	Cd	E	F	G	H	Kv	M	T	Tv	V	Wv	
●	●	●	●	●	●	●	-	-	-	-	●	-	●	-	

- applicable without restrictions

A Soffit installation

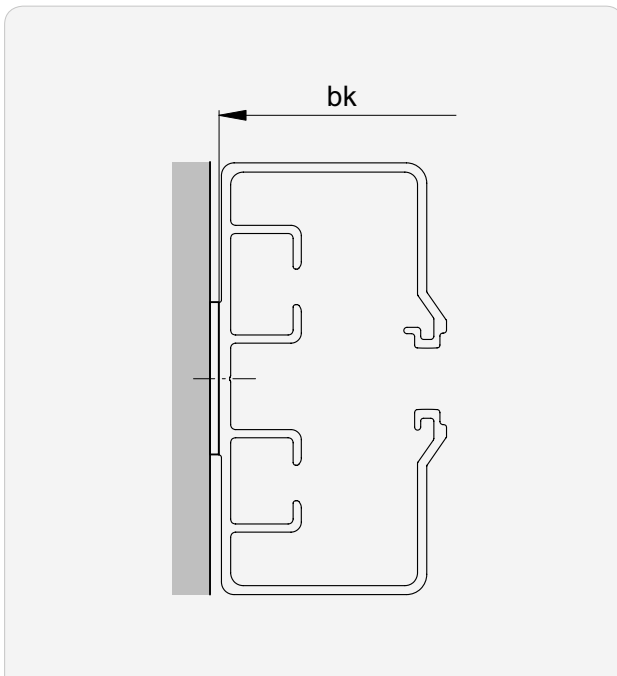

- i** Observe possible guide rail spacer for **bk**.
Standard: 2 mm

►► Guide rail fastenings (principle)

B Installation with fastening bracket

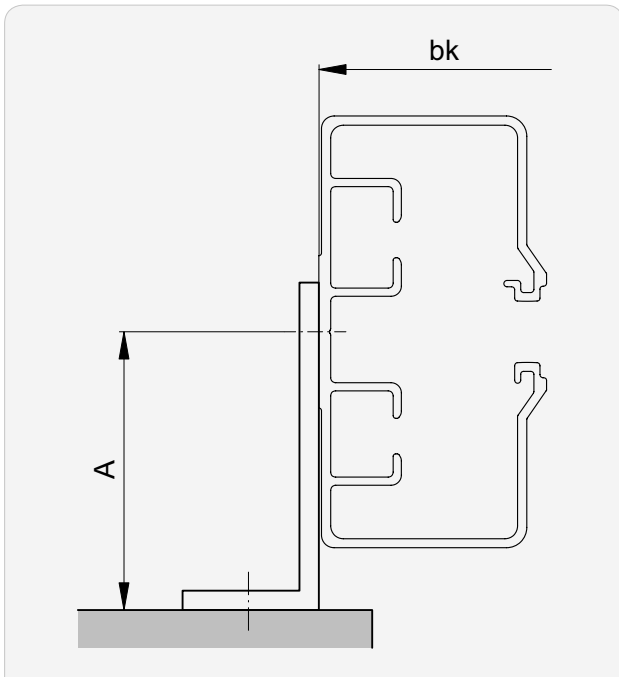

Bracket outwards

C Installation with fastening bracket

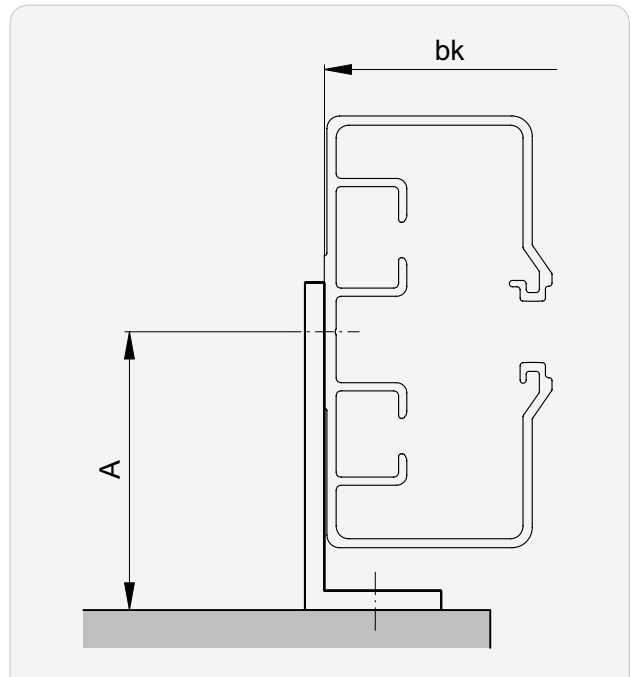

Bracket inwards

Fastening bracket for types B and C

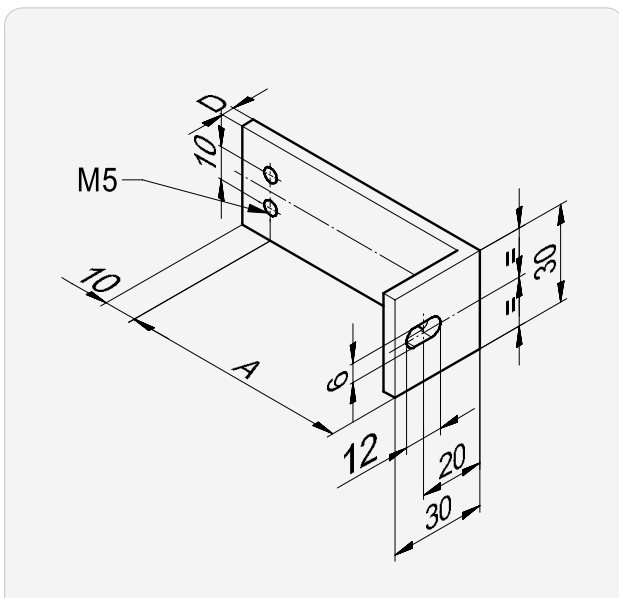

A*	D
20... 115	4

Fastening bracket 70mm for types B and C

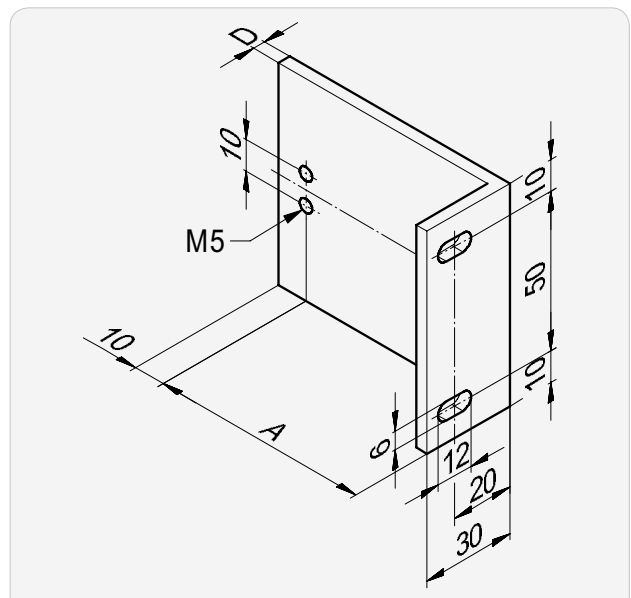

A*	D
20... 115	4
120... 215	5

i For suspended guide rails always with **brackets 70mm**.

i If the **projection is ≥ 120**, all products are fastened with a **70mm bracket**.

* in 5 mm steps

►► Guide rail fastenings (principle)

Bd Installation with continuous fastening bracket

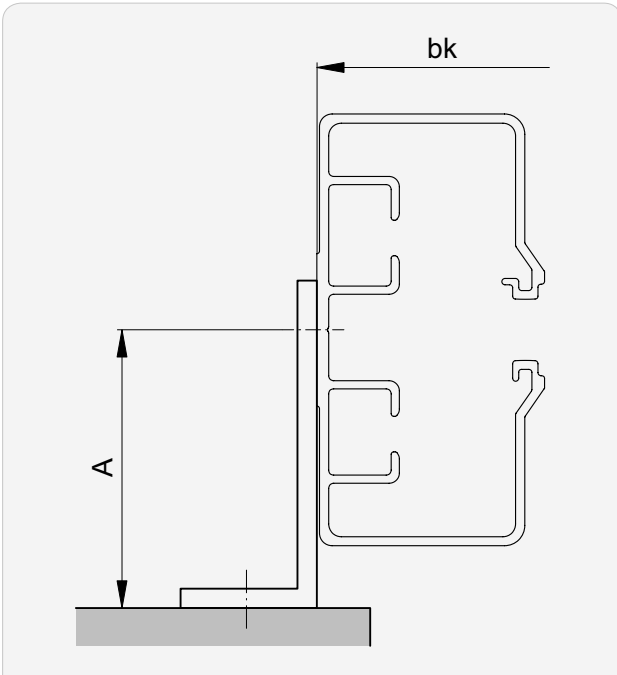

Bracket outwards

Cd Installation with continuous fastening bracket

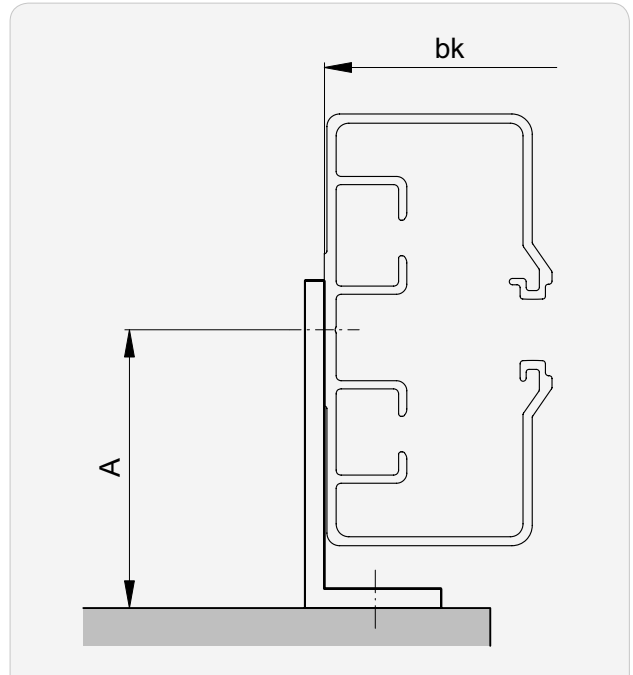

Bracket inwards

Continuous fastening bracket for types Bd and Cd

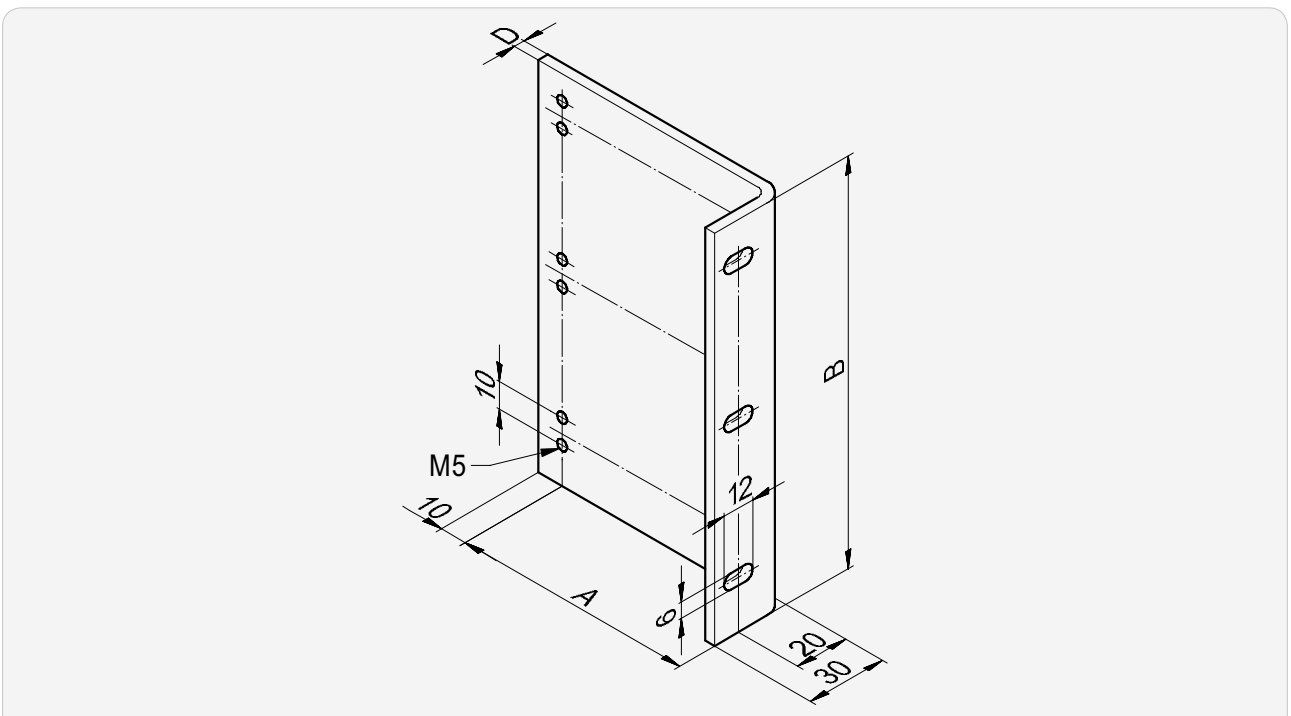

A*
20 ... 300

D
always 4

* in 5 mm steps

►► Guide rail fastenings (principle)

E|F Installation with fastening lug

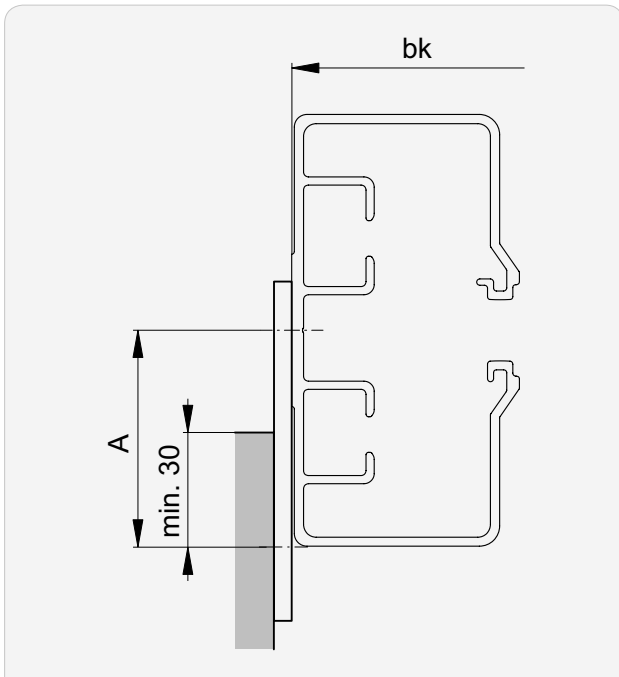

inwards / outwards

T Installation with T-bracket

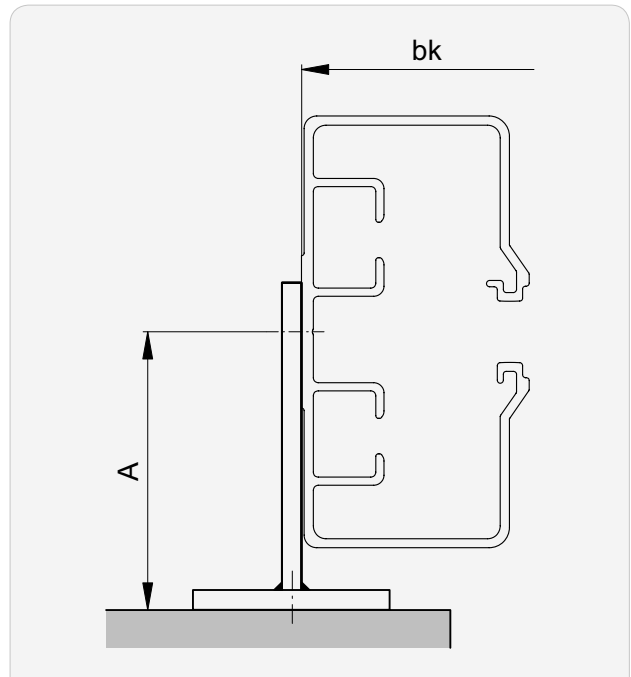

Fastening lug for type E | F

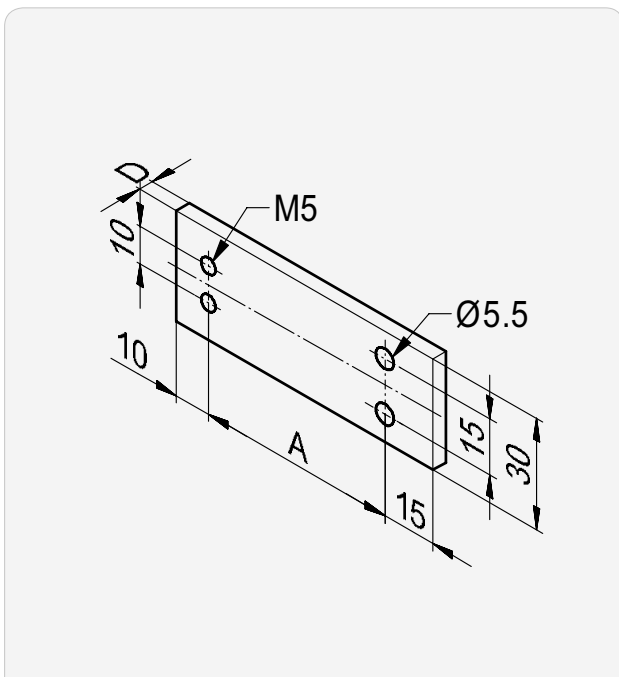

A*	D
50... 115	4
120... 125	5

T-bracket for type T

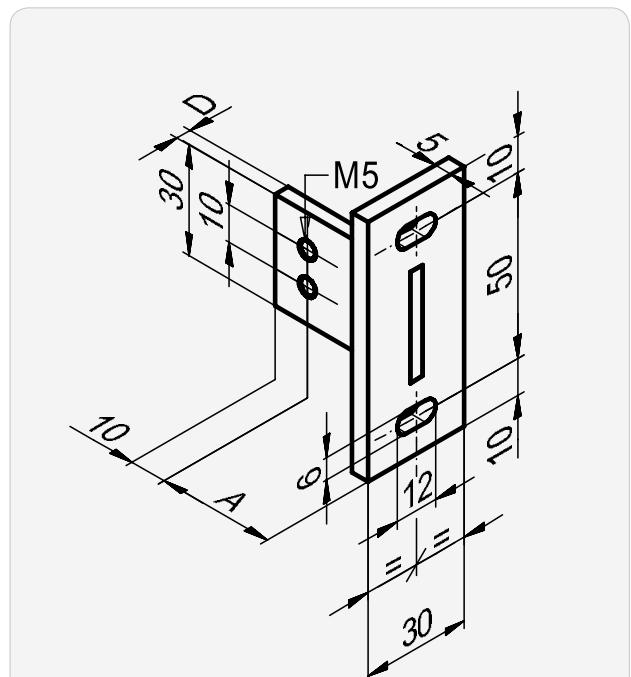

A*	D
20... 115	4
120... 215	5

* in 5 mm steps

►► Guide rail fastenings (principle)

V Installation with one bracket

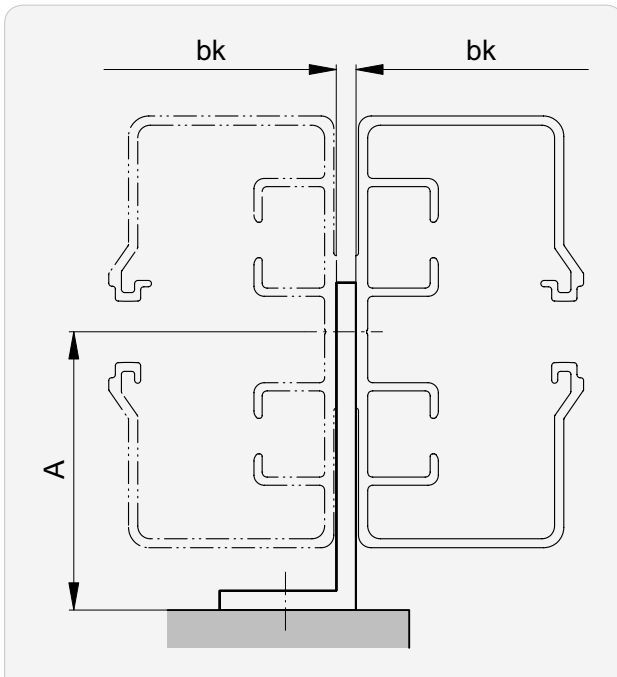

The blind on the right uses the fastening for the blind on the left.

Guide extension and facet

Extension

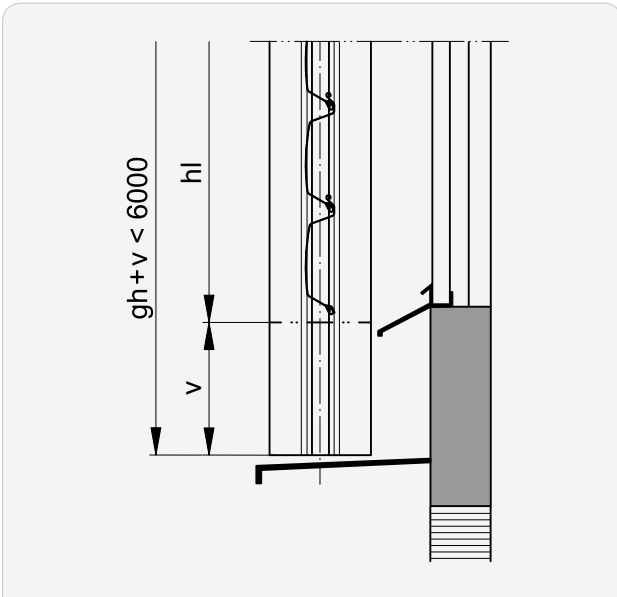

v
0...3000

Facet

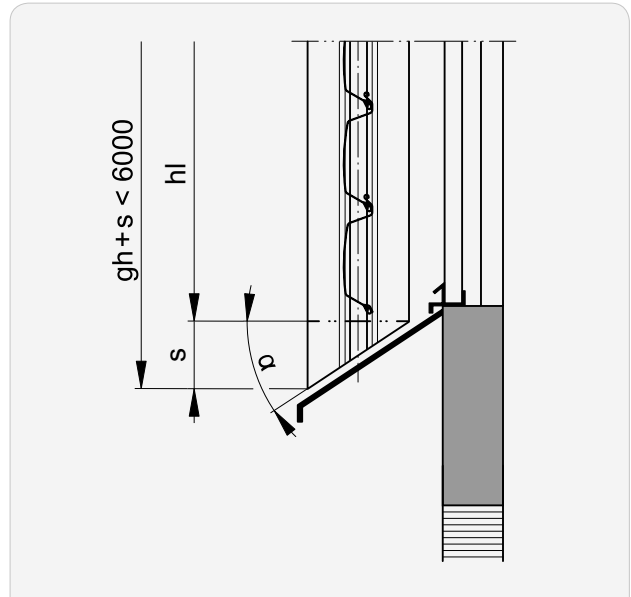

alpha
5...60°

Extension and facet

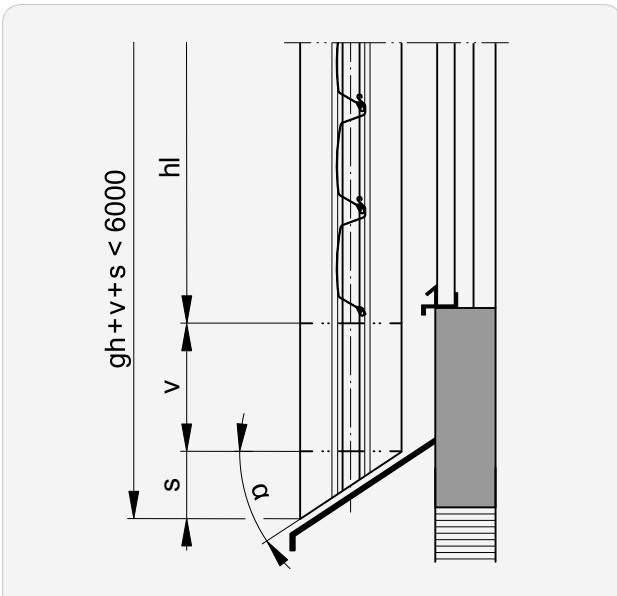

v
0...3000

alpha
5...60°

Angling at the guides

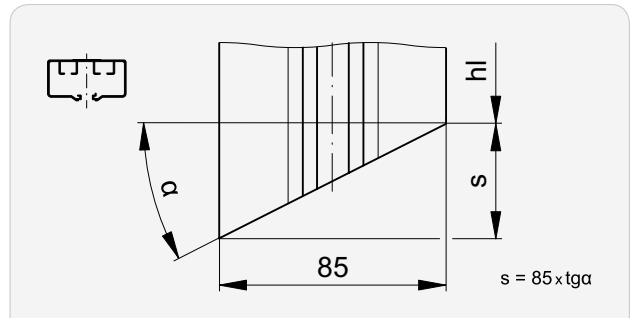

alpha	s	alpha	s	alpha	s	alpha	s	alpha	s
5	7	15	23	25	40	35	60	45	85
6	9	16	24	26	41	36	62	46	88
7	10	17	26	27	43	37	64	47	91
8	12	18	28	28	45	38	66	48	94
9	13	19	29	29	47	39	69	49	98
10	15	20	31	30	49	40	71	50	101
11	17	21	33	31	51	41	74	51	105
12	18	22	34	32	52	42	77	52	109
13	20	23	36	33	55	43	79	53	113
14	21	24	38	34	57	44	82	54	117

Guide rail cut-outs in windowsill area

! Rear cut-out in combination with inner cut-out not possible!

Rear cut-out | with extension / with extension and facet

Extension

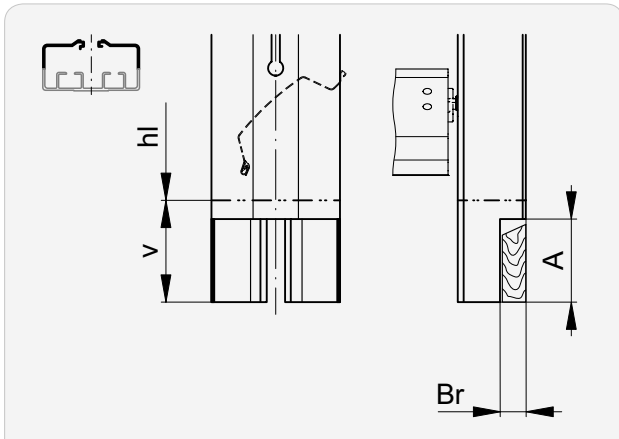

$$A \leq v$$

0 ... 130

Br

0 ... 13

17 ... 25

Extension and facet

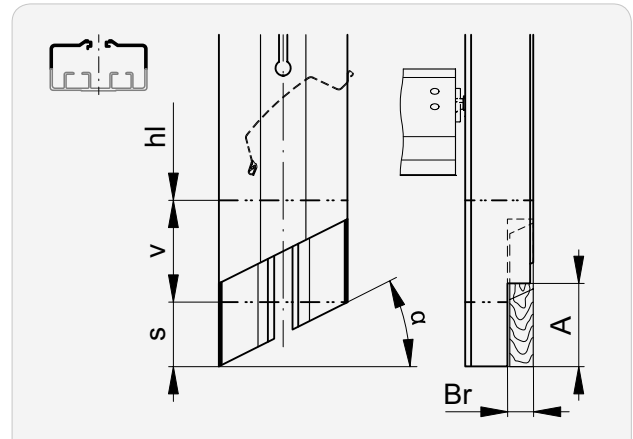

$$A \leq (v + s)$$

0 ... 35

Br

0 ... 13

17 ... 25

α

0° ... 30°

Inner cut-out | without / with extension

Without extension

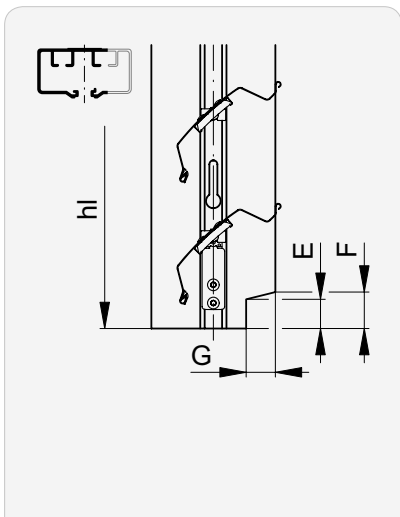

E

0 ... 20

F

0 ... 25

G

0 ... 20

Extension | $v \leq F$

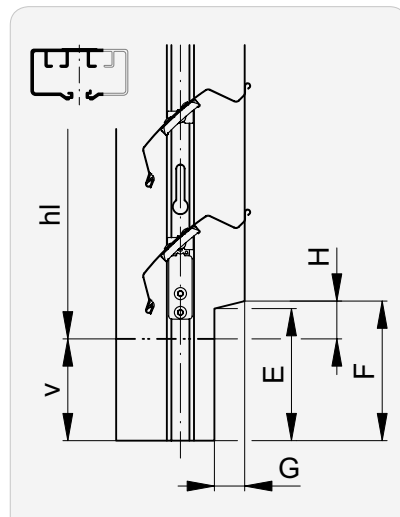

E

0 ... 130

F

0 ... 180

G

0 ... 20

H

0 ... 25

Extension | $v > F$

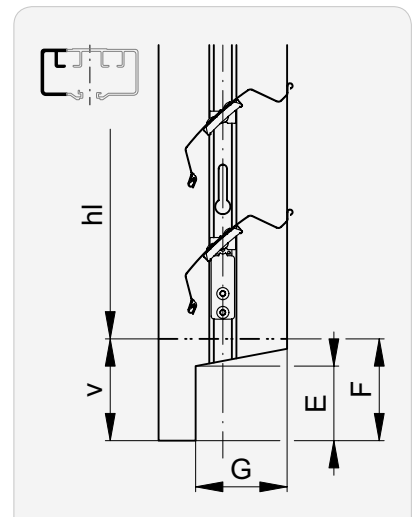

E

0 ... 130

F

0 ... 180

G

0 ... 20
37 ... 48
54 ... 78

v Guide rail extension: 0 ... 3000

►► Guide rail cut-outs in windowsill area

Inner cut-out | with facet

Facet | $s \leq F$

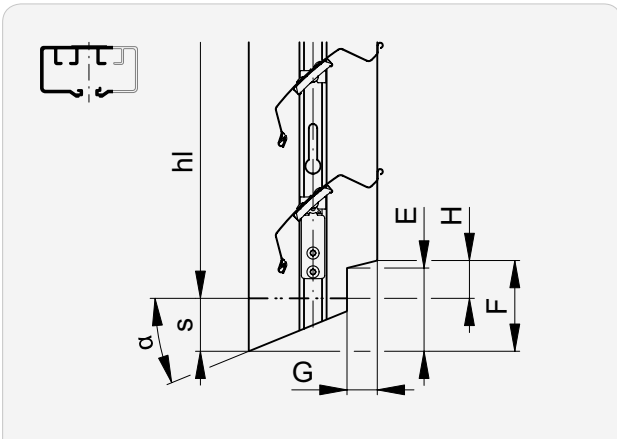

E	F	G	H
0...130	0...180	0...20	0...25

Facet | $s > F$

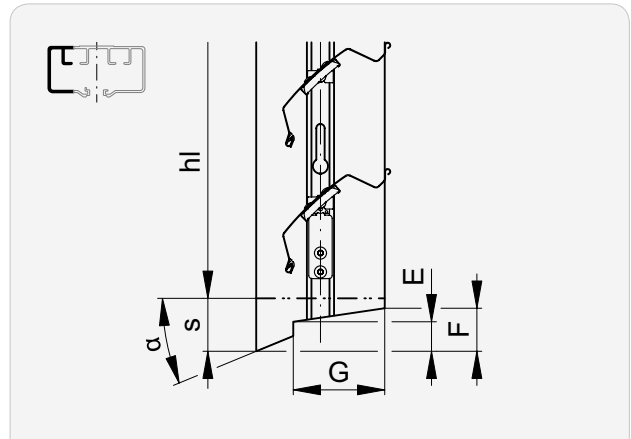

E	F	G
0...130	0...180	0...20
		37...48
		54...78

Inner cut-out | with extension and facet

Extension and facet | $(v + s) \leq F$

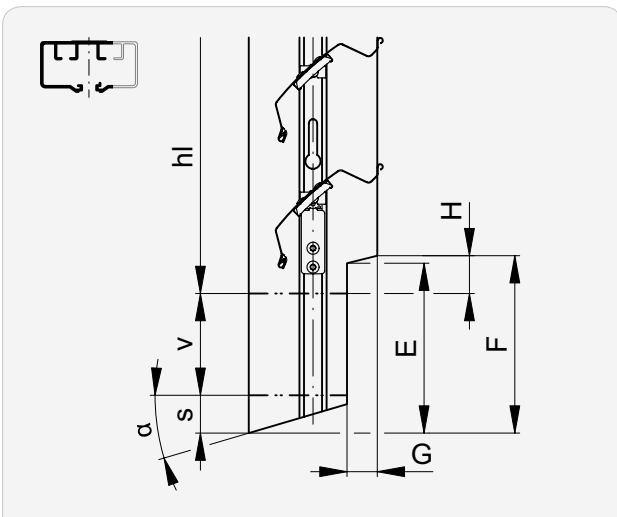

E	F	G	H
0...130	0...180	0...20	0...25

Extension and facet | $(v + s) > F$

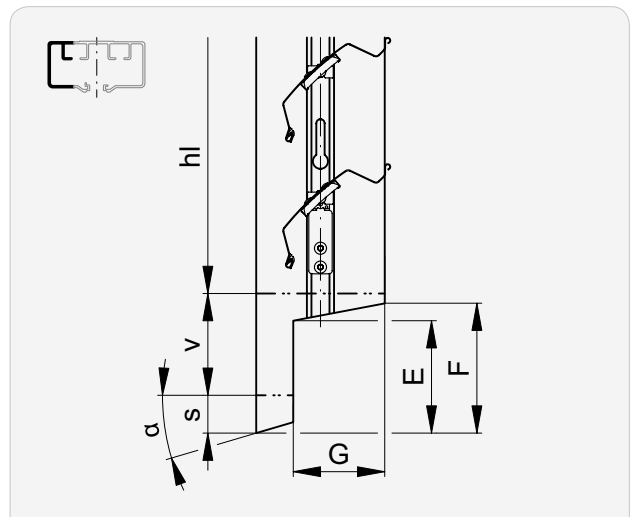

E	F	G
0...130	0...180	0...20
		37...48
		54...78

v Guide rail extension: 0...3000

Fastening points

Without extension

Z	AS
≤ 1500	2
1501 ... 2700	3
2701 ... 3900	4
3901 ... 5100	5
> 5100	6

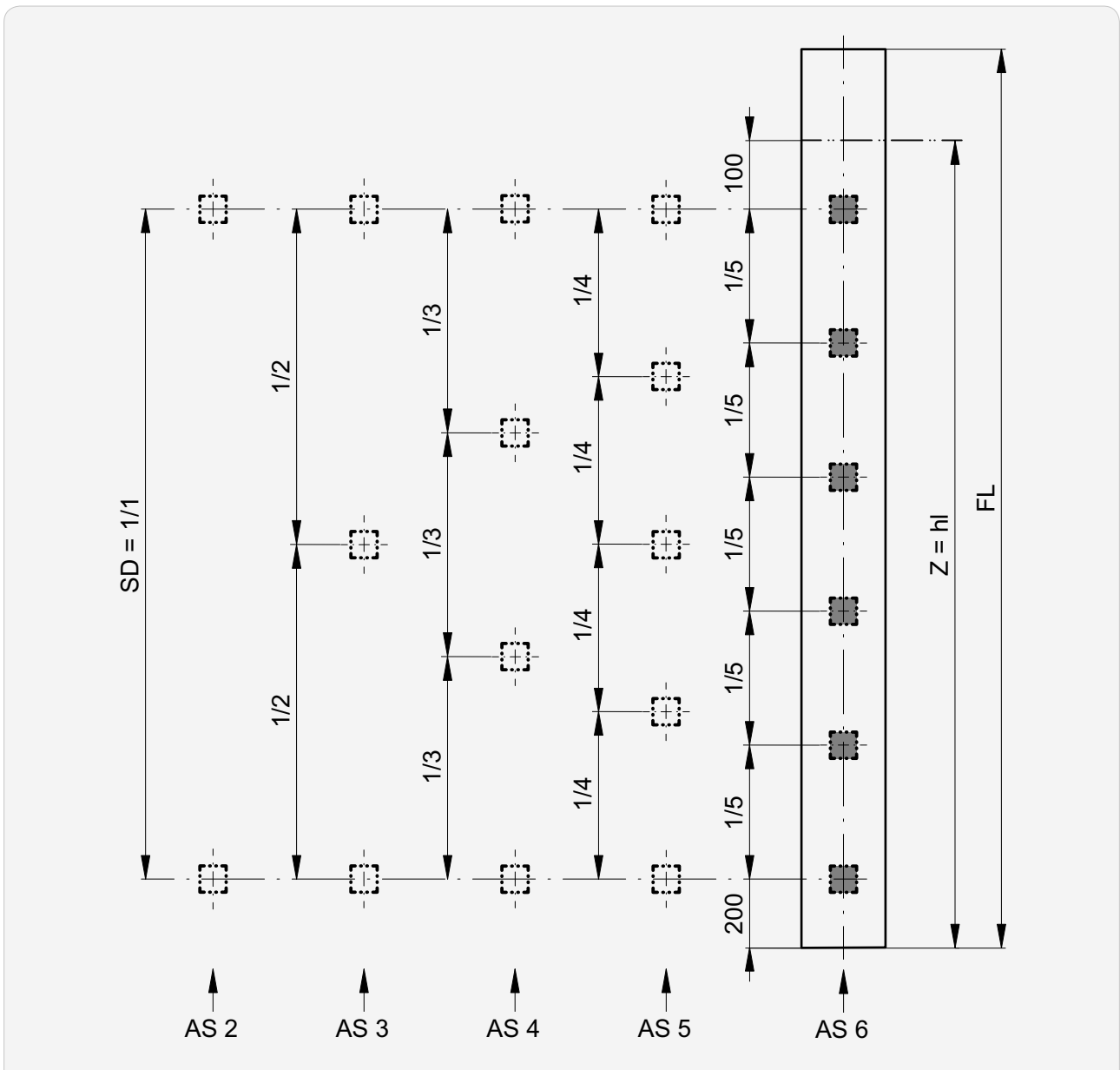

AS Number of slits

SD Slot spacing: max. 1200

►► Fastening points

With guide rail extension

Z	AS
≤ 1500	2
1501 ... 2700	3
2701 ... 3900	4
3901 ... 5100	5
> 5100	6

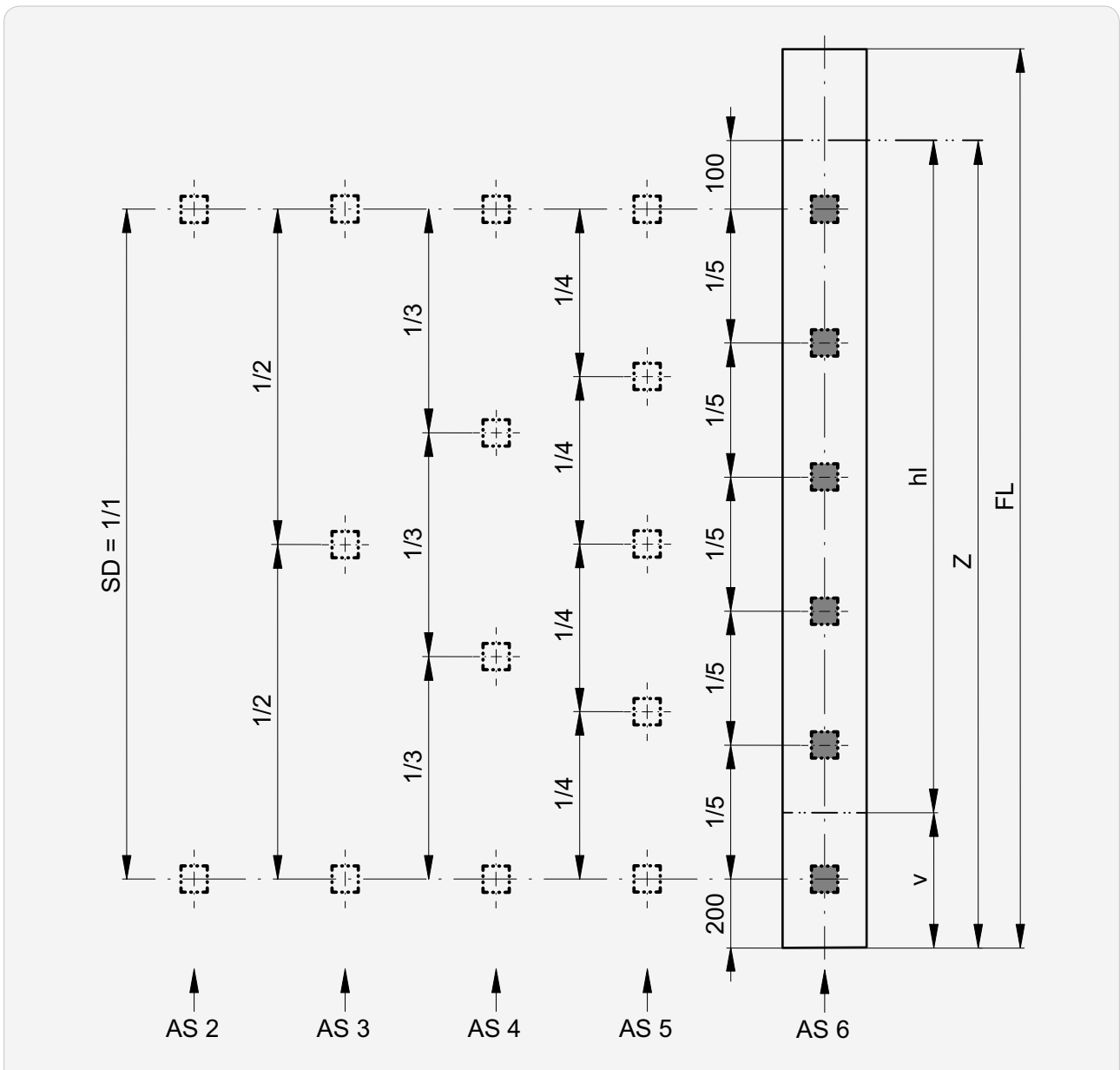

AS Number of slits

v Guide rail extension: max. 1000

SD Slot spacing: max. 1200

►► Fastening points

With facet

Z	AS
≤ 1500	2
1501 ... 2700	3
2701 ... 3900	4
3901 ... 5100	5
> 5100	6

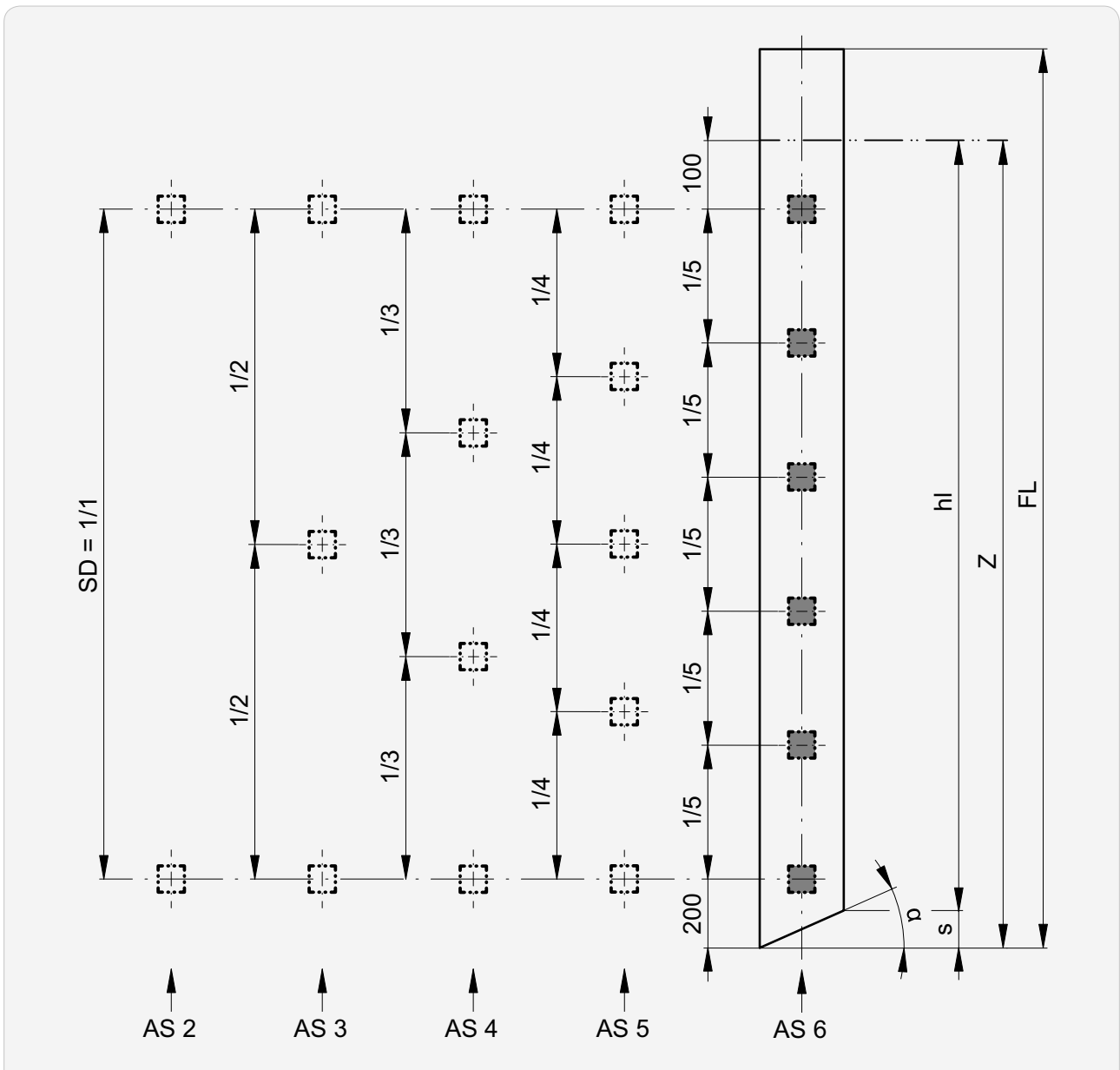

AS Number of slits

SD Slot spacing: max. 1200

s Faceting (guide rail width x tgα)

►► Fastening points

With guide rail extension and facet

Z	AS
≤ 1500	2
1501 ... 2700	3
2701 ... 3900	4
3901 ... 5100	5
> 5100	6

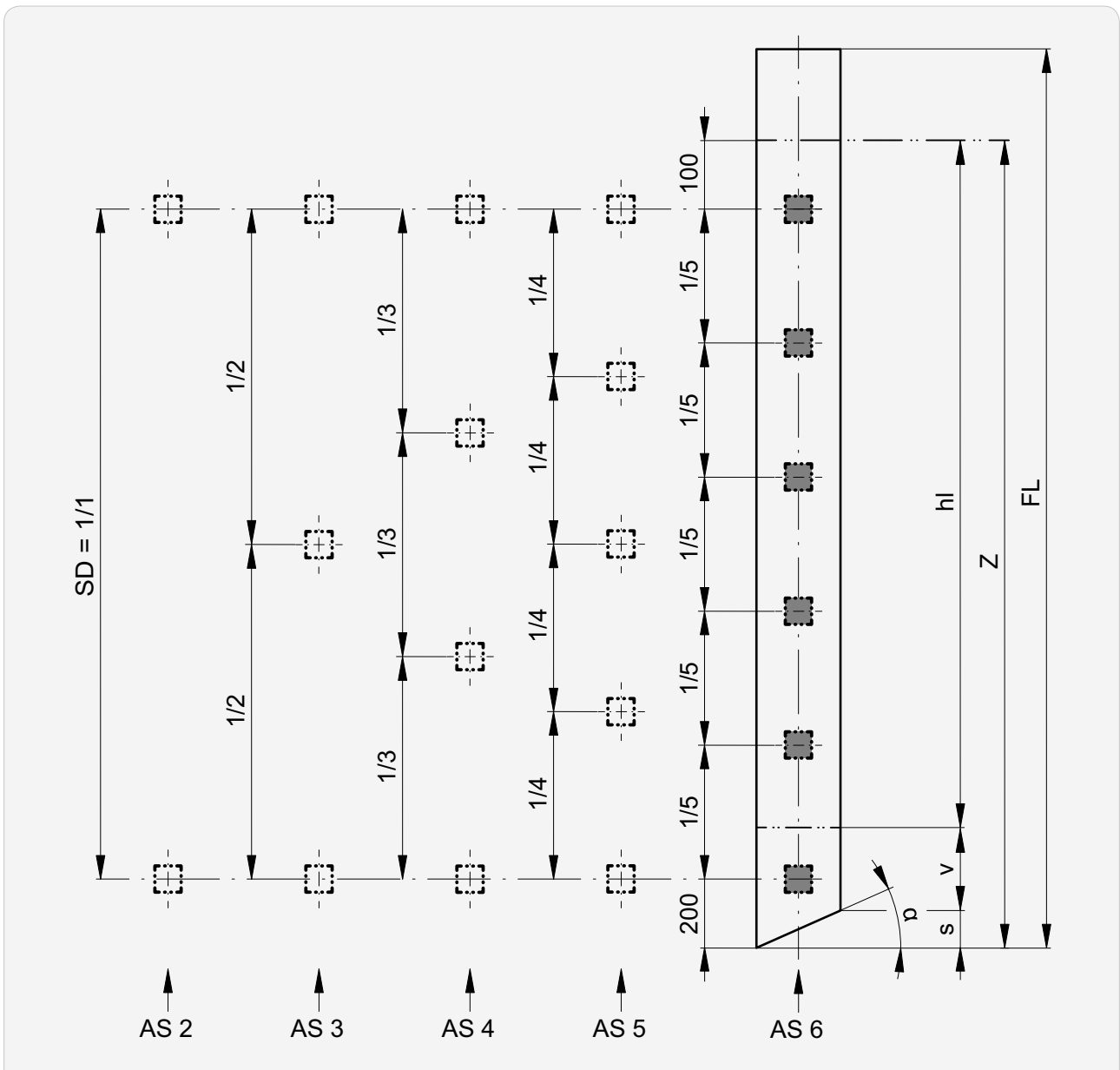

AS Number of slits

s Faceting (guide rail width x tgα)

SD Slot spacing: max. 1200

v Guide rail extension: max. 1000

Connected systems

System width

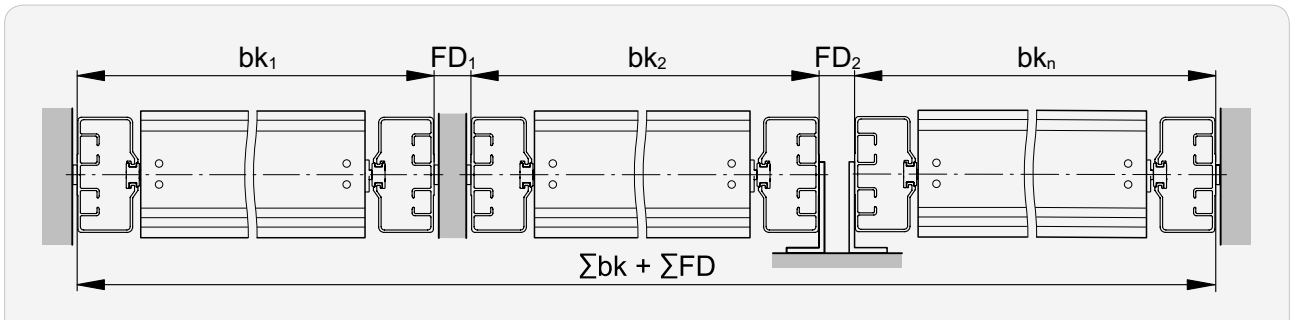

Distance between guides FD

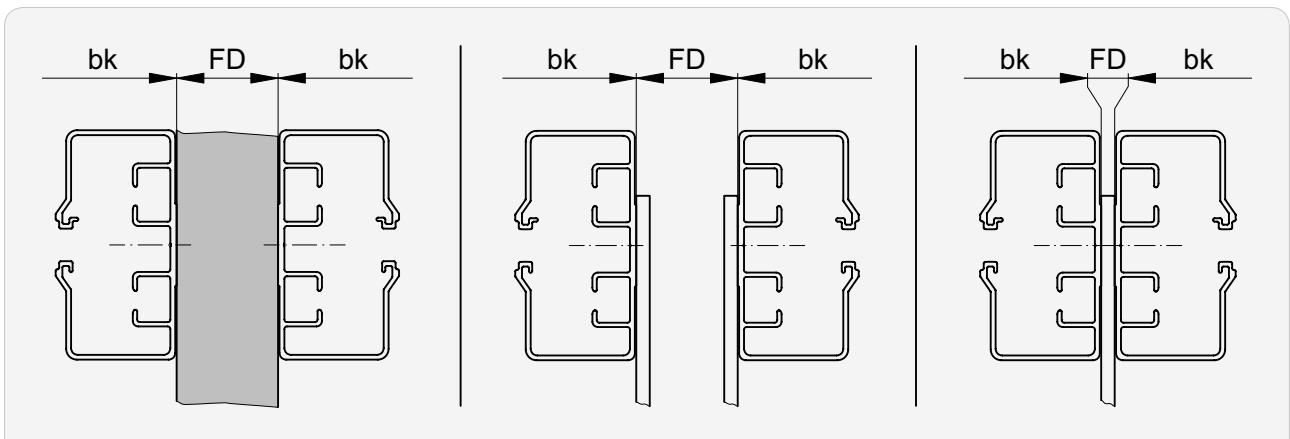

FD min.	FD max.
5	1000

►► Connected systems

Drive position

Gearbox

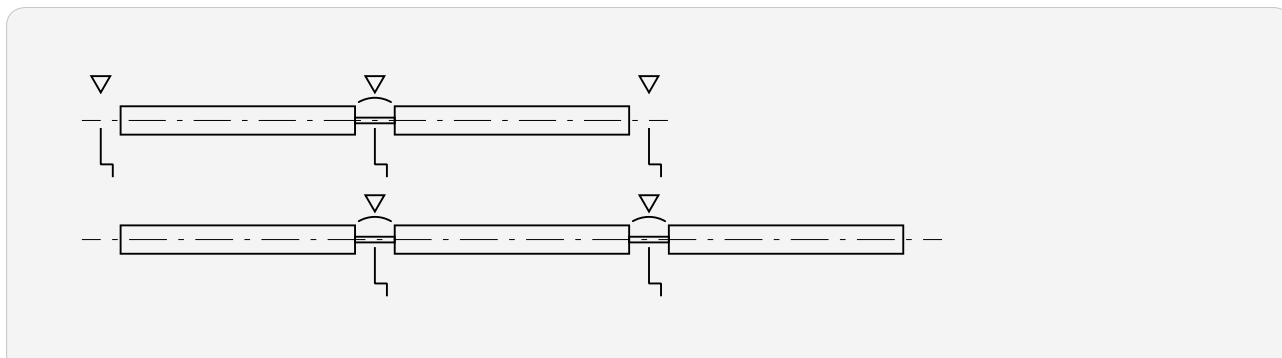

Motor

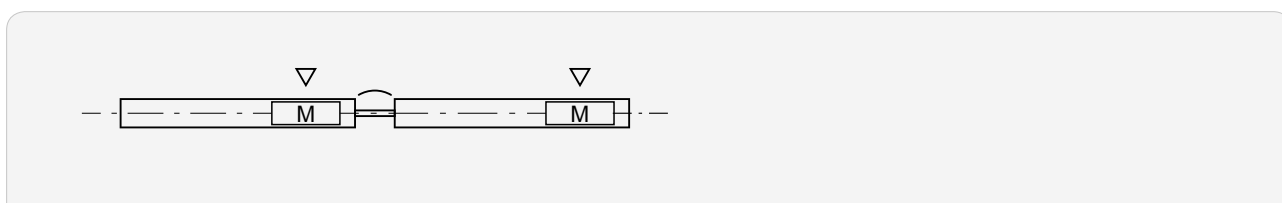

▼ Standard drive position

▽ Possible drive position

Opening for connected blinds

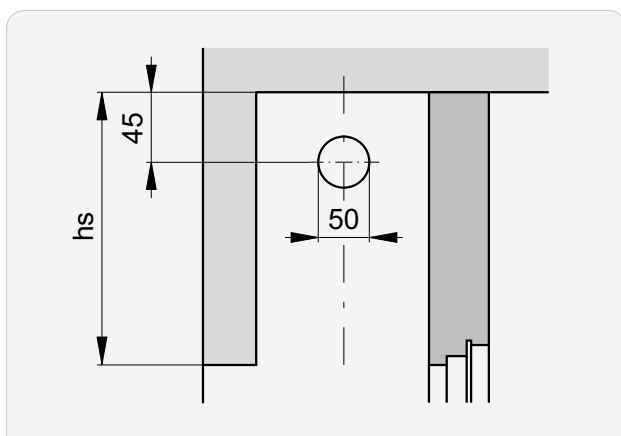

Technical data of motors

Performance characteristics

Type	Limit switch		M [Nm]	n [1/min.]	P [W]	I [A]
	Type	Number of				
Standard						
Elero Comfort						
ECM...	06.01	electronic	6	26	115	0.50
	09.01		9		156	0.68
	06.51	electronic	6		115	0.50
	09.51		3		9	156
ECB...	06.51	electronic	6	26	115	0.50
	09.51		3		9	156

I Current consumption

M Torque

n Rotational speed

P Power consumption



Grinotex® III | Grinotex® III Sinus

Limit dimensions	34
Built-in system	35
Built-in system with cover	35
Header dimensions Grinotex® III	36
Heights of package Grinotex® III	36
Header dimensions Grinotex® III Sinus	37
Heights of package Grinotex® III Sinus	37
Slat profiles	38
End rail	38
Beginning distance Slot spacing	39
Housing fastening	40
Number of box supports	42
Darkening	43
Guide rail	44
Sections Details	45
Sections for crank drive (MBMA)	46
Vertical connections Standard motor position	47
Guide rail installation (principle)	52
Guide rail fastenings (principle)	54
Guide extension and facet	59
Guide rail cut-outs in windowsill area	60
Installation window	64
Fastening points	65
Connected systems	70
Technical data of motors	72



Limit dimensions

Single blind

Operation	Width min. (bk)	Width ¹ max. (bk)	Height min. (hl)	Height max. (hl)	Surface ² max. [m ²]
Crank drive	600 800 ³	4000	380	4250	8*
Motor drive	760 825 ⁴				8

Connected systems

Operation	Width ¹ max. (bk)	Height max. (hl)	Blinds max.	Blinds per system	Surface ² max. [m ²]
Crank drive ⁵	10 000	4250	3	2	8*
Motor drive	5500		2	2	6.5*

¹ For buildings and high-rise structures, which are exposed to high winds, this maximum value should be decreased as required. Also see wind classes data sheet.

² If crank drive is in slat area: maximum surface area and crank position available on request.

³ Gearbox in slat area.

⁴ Motor drive with operating position.

⁵ In the case of 3 connected blinds, the drive should be positioned between two blinds.

* with MBMA– on request

Built-in system

Vertical section: Grinotex® III

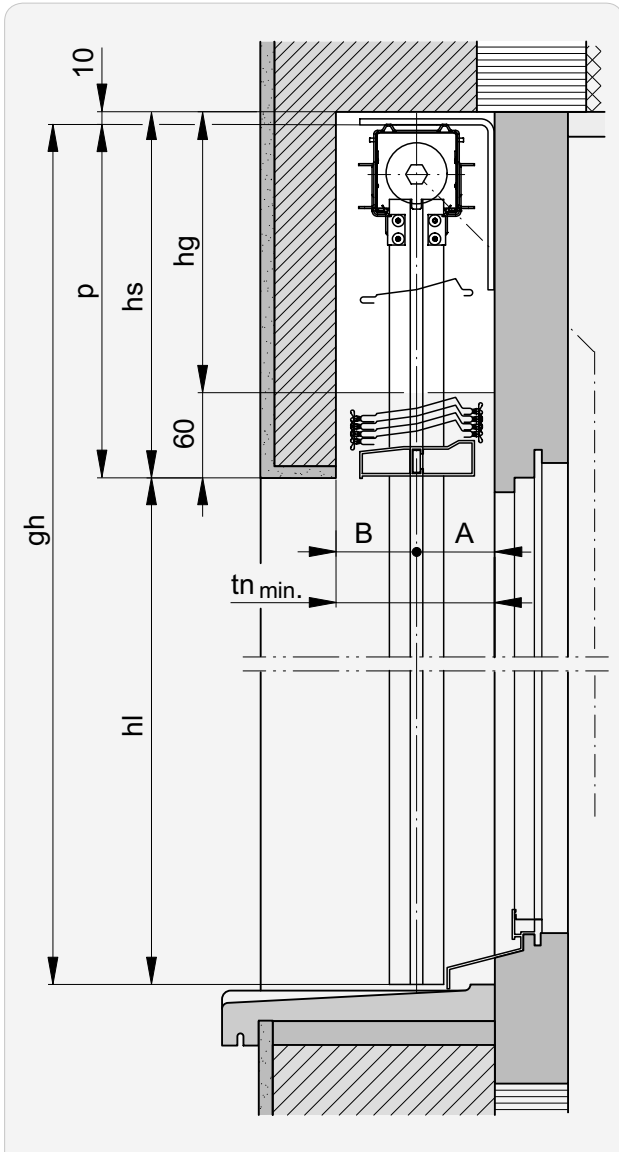

Built-in system with cover

Vertical section: Grinotex® III Sinus

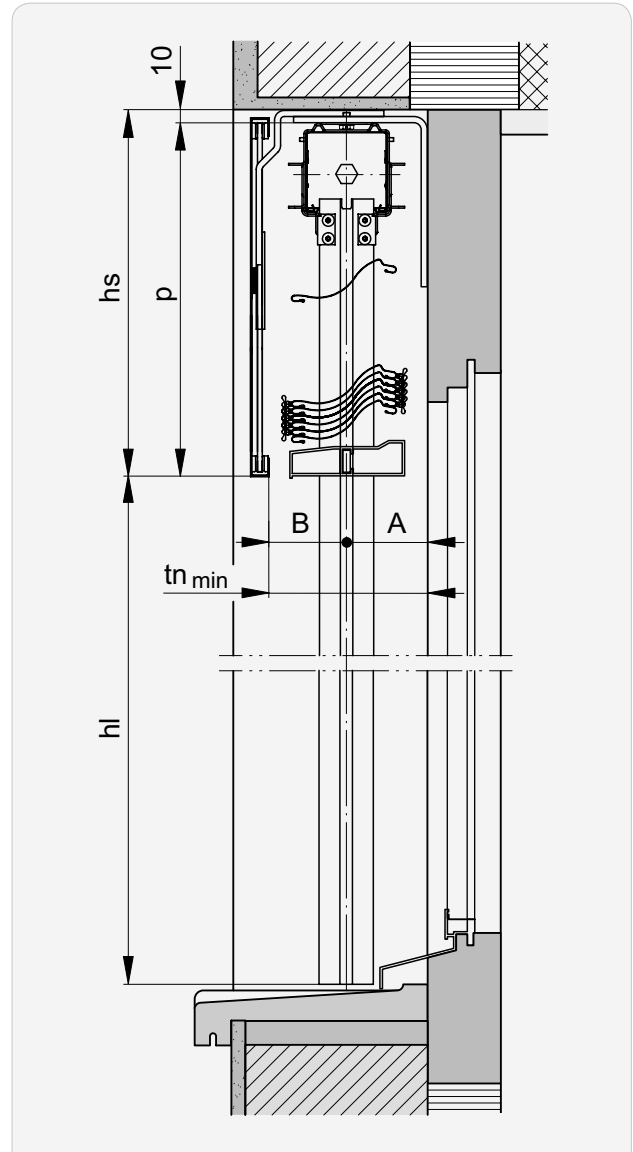

Horizontal section: Grinotex® III

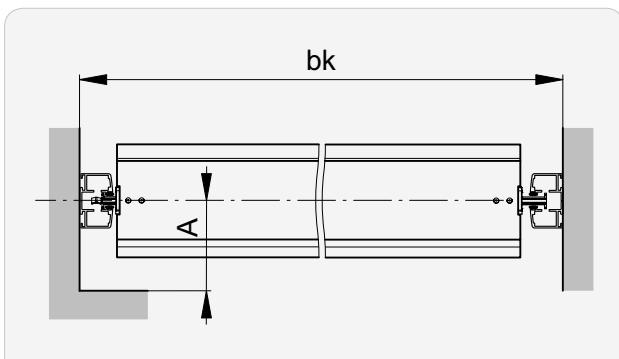

Horizontal section: Grinotex® III Sinus

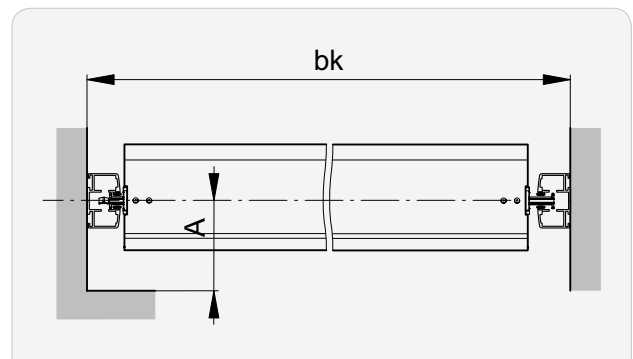

Header dimensions Grinotex® III

hl →	hs ¹									tn min.	A	B			
	bk ≤2000	2001– 2250	2251– 2500	2501– 2750	2751– 3000	3001– 3250	3250– 3500	3501– 3750	3751– 4000						
1250	230	230	230	245	245	245	255	255	255	130*	65	65			
1500	245	245	245	260	260	260	275	275	275						
1750	265	265	280	280	280	290	290	290	290						
2000	280	280	295	295	295	310	310	310	310						
2250	300	300	315	315	315	325	325	325	325						
2500	315	315	330	330	345	345	345	345							
2750	335	335	350	350	360	360									
3000	350	365	365	365	380										
3250	370	385	385	385											
3500	390	405	405												
3750	410	425	425												
4000	425	440													
4250	445	460													
End rail	23mm	38mm	50mm												

Heights of package Grinotex® III

hl →	p									tn min.	A	B			
	bk ≤2000	2001– 2250	2251– 2500	2501– 2750	2751– 3000	3001– 3250	3250– 3500	3501– 3750	3751– 4000						
1250	220	220	220	235	235	235	245	245	245	130*	65	65			
1500	235	235	235	250	250	250	265	265	265						
1750	255	255	270	270	270	280	280	280	280						
2000	270	270	285	285	285	300	300	300	300						
2250	290	290	305	305	305	315	315	315	315						
2500	305	305	320	320	335	335	335	335							
2750	325	325	340	340	350	350									
3000	340	355	355	355	370										
3250	330	375	375	375											
3500	380	395	395												
3750	400	415	415												
4000	415	430													
4250	435	450													
End rail	23mm	38mm	50mm												

¹ With gearbox in slat area: **hs + 20**.

* + possible addition for protruding weatherboard or doorknobs.

i Header dimensions are approximate values which may exhibit **negative or positive deviations** depending on the technical circumstances. **A dimensional tolerance of ±5 mm** is observed for the header height.

Header dimensions Grinotex® III Sinus

hl →	hs ¹									tn min.	A	B			
	bk ≤2000	2001– 2250	2251– 2500	2501– 2750	2751– 3000	3001– 3250	3250– 3500	3501– 3750	3751– 4000						
750	230	230	230	230	230	230	235	235	235	130*	65	65			
1000	230	230	230	240	240	240	255	255	255						
1250	245	245	245	260	260	260	270	270	270						
1500	260	260	260	275	275	275	290	290	290						
1750	285	285	300	300	300	310	310	310	310						
2000	300	300	315	315	315	330	330	330	330						
2250	320	320	335	335	335	345	345	345	345						
2500	340	340	355	355	365	365	365	365							
2750	355	355	370	370	380	380									
3000	380	395	395	395	405										
3250	395	410	410	410											
3500	410	425	425												
3750	430	445	445												
4000	455	470													
4250	470	485													
End rail	23mm	38mm				50mm									

Heights of package Grinotex® III Sinus

hl →	p									tn min.	A	B			
	bk ≤2000	2001– 2250	2251– 2500	2501– 2750	2751– 3000	3001– 3250	3250– 3500	3501– 3750	3751– 4000						
750	220	220	220	220	220	220	225	225	225	130*	65	65			
1000	220	220	220	230	230	230	245	245	245						
1250	235	235	235	250	250	250	260	260	260						
1500	250	250	250	265	265	265	280	280	280						
1750	275	275	290	290	290	300	300	300	300						
2000	290	290	305	305	305	320	320	320	320						
2250	310	310	325	325	325	335	335	335	335						
2500	330	330	345	345	355	355	355	355							
2750	345	345	360	360	370	370									
3000	370	385	385	385	395										
3250	385	400	400	400											
3500	400	415	415												
3750	420	435	435												
4000	445	460													
4250	460	475													
End rail	23mm	38mm				50mm									

¹ With gearbox in slat area: **hs + 20**.

* + possible addition for protruding weatherboard or doorknobs.

i Header dimensions are approximate values which may exhibit **negative or positive deviations** depending on the technical circumstances. **A dimensional tolerance of ±5 mm** is observed for the header height.

Slat profiles

Grinotex® III

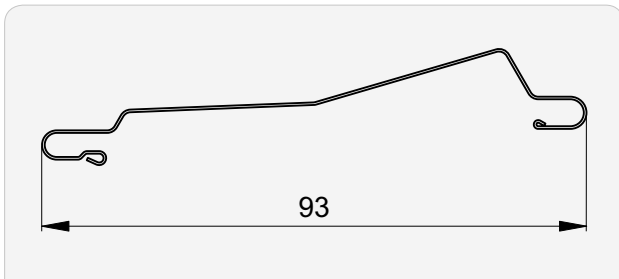

Grinotex® III Sinus

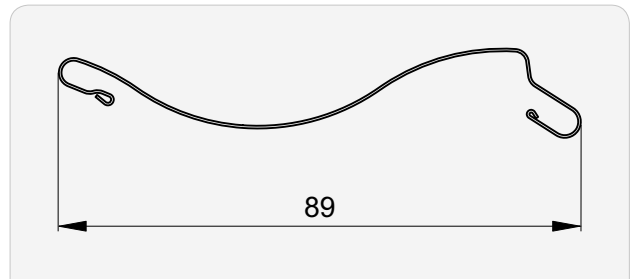

End rail

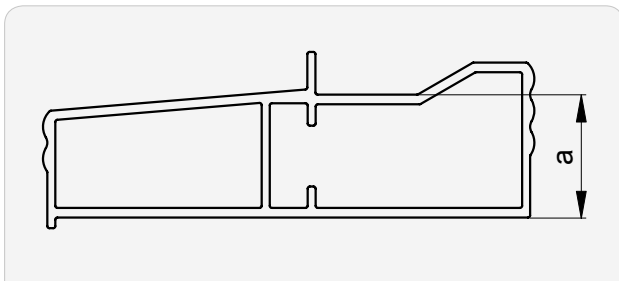

a

23

38

50

Beginning distance | Slot spacing

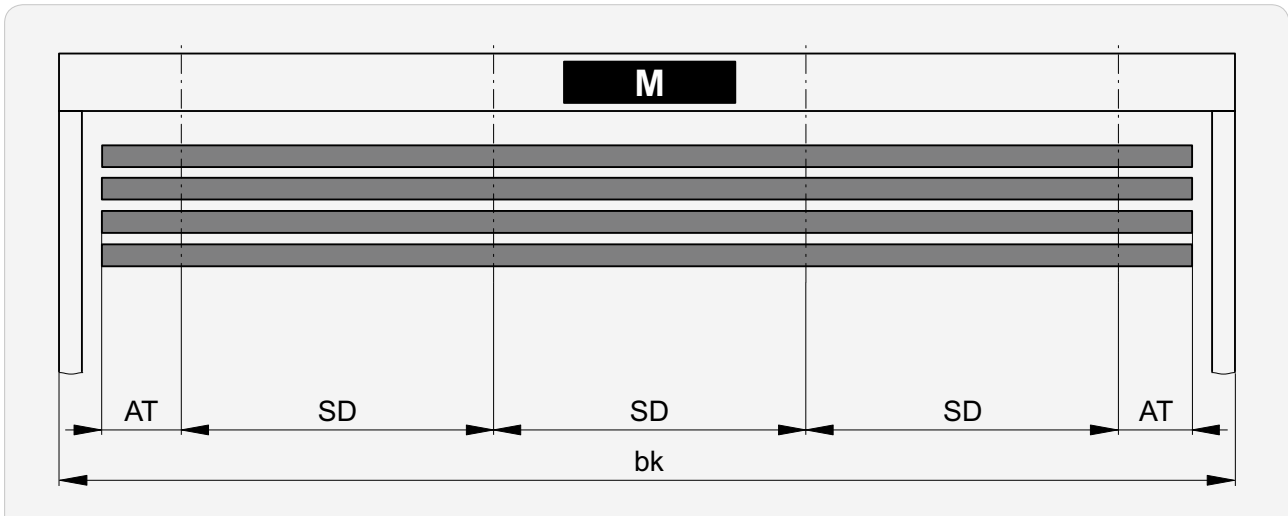

bk	AT min.		SD min.	SD max.
	without operating position	with operating position		
≤ 750	100	130		
751 ... 1000	120	130		
> 1000	200	200	335*	800*
Special	80 ¹ / 250 ¹	110 ¹ / 250 ¹		

¹ on request

* Standard slot spacing machine fabrication

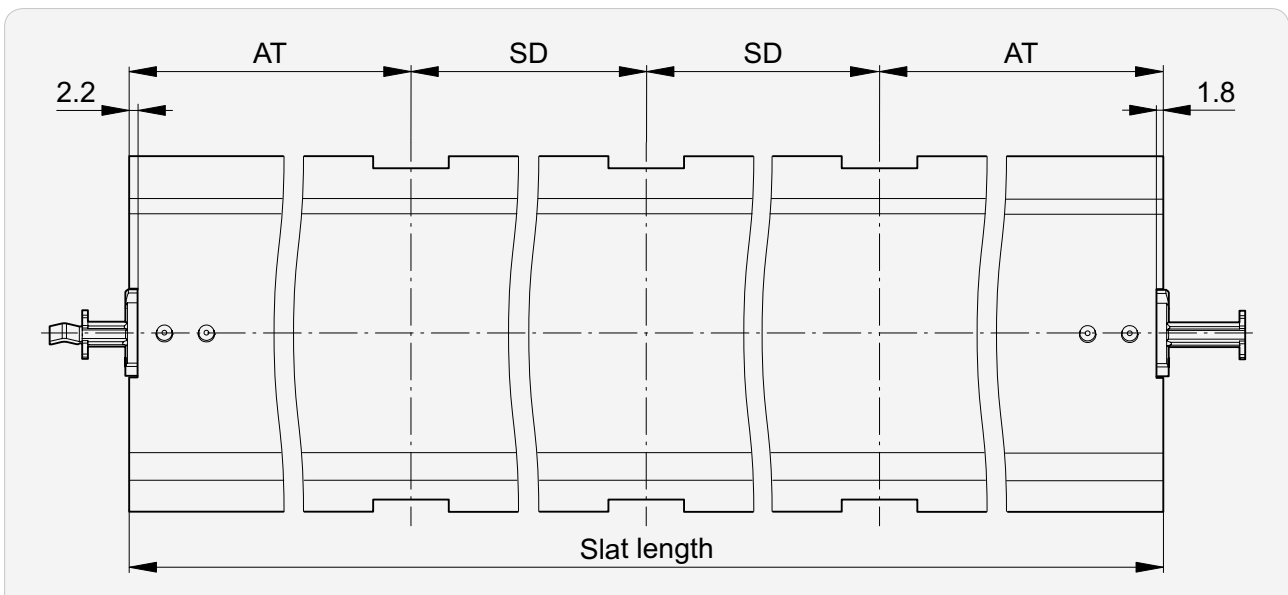

AT Beginning distance
Distance from beginning of slat to centre of bearing

SD Slot spacing
Distance from centre of bearing (slot) to centre of bearing (slot)

Housing fastening

At top

NO

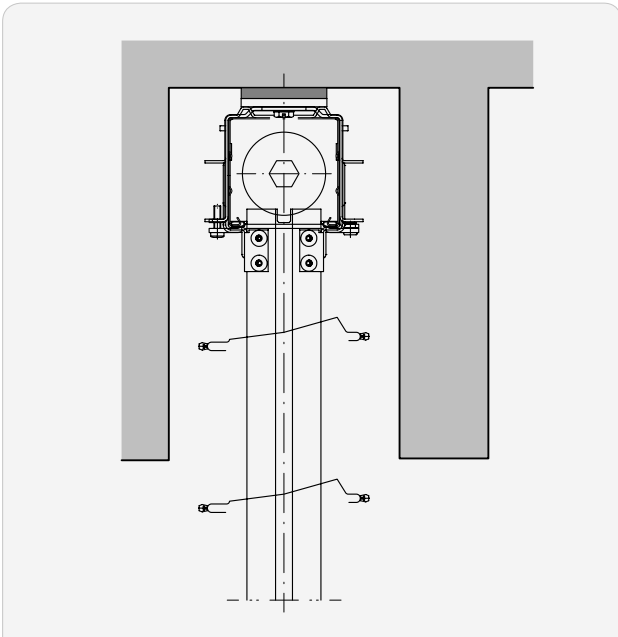

Box support

KT

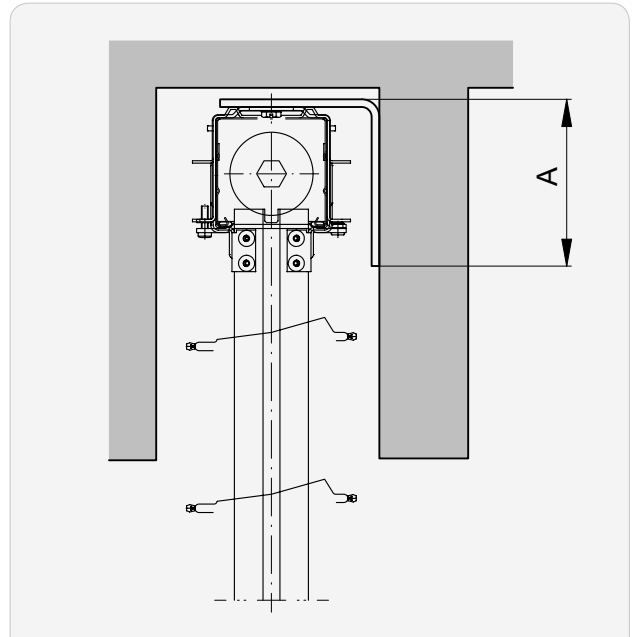

Box support for type KT, for small headers*

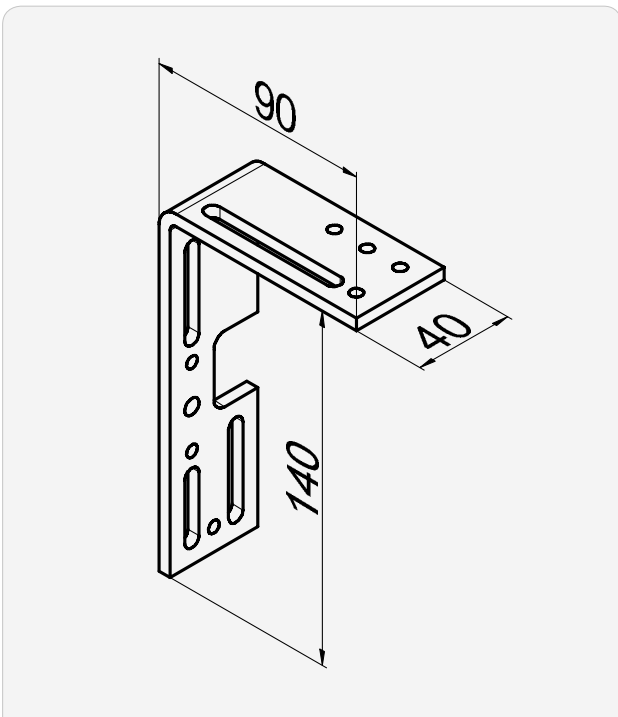

A
140

* Header 100

Box support for type KT

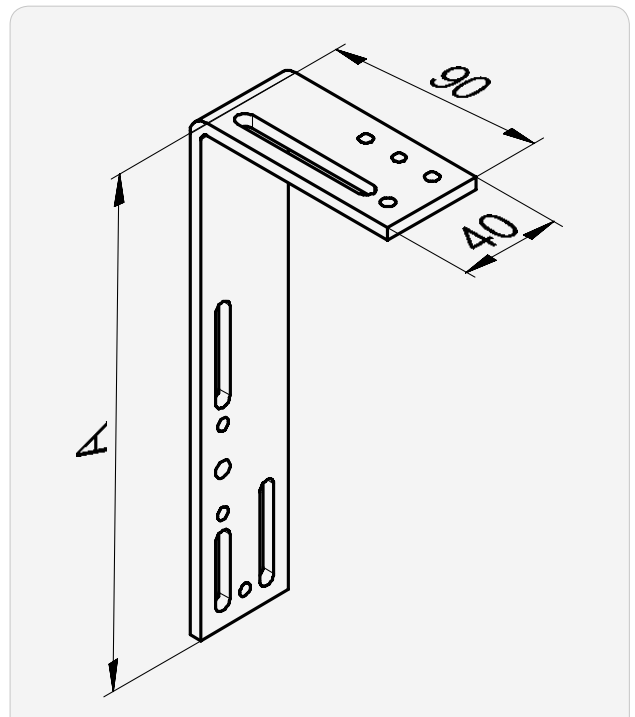

A
200
260

►► Housing fastening

Double box support

DR

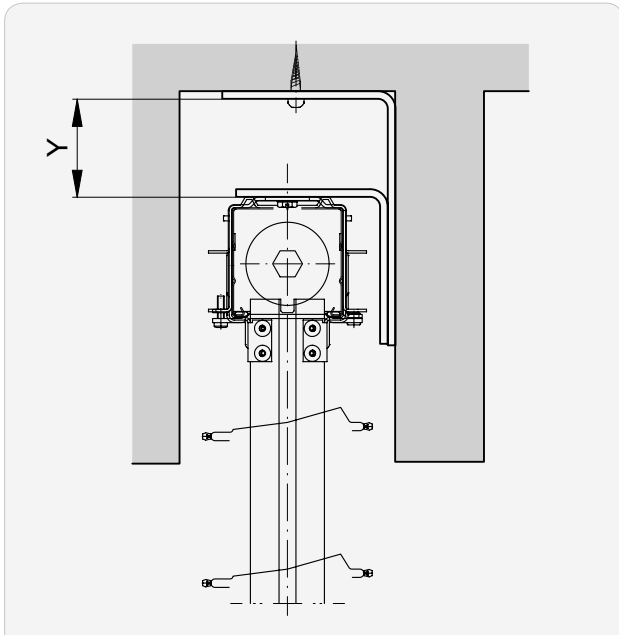

Gallery clip

GB

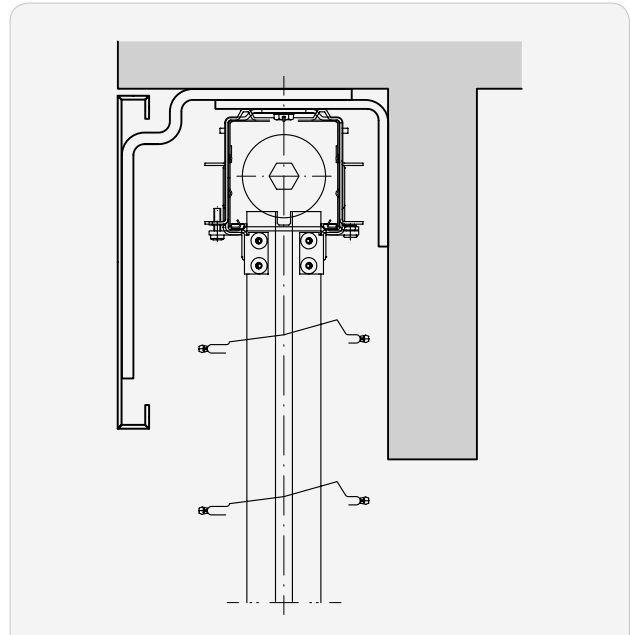

Double box support for type DR

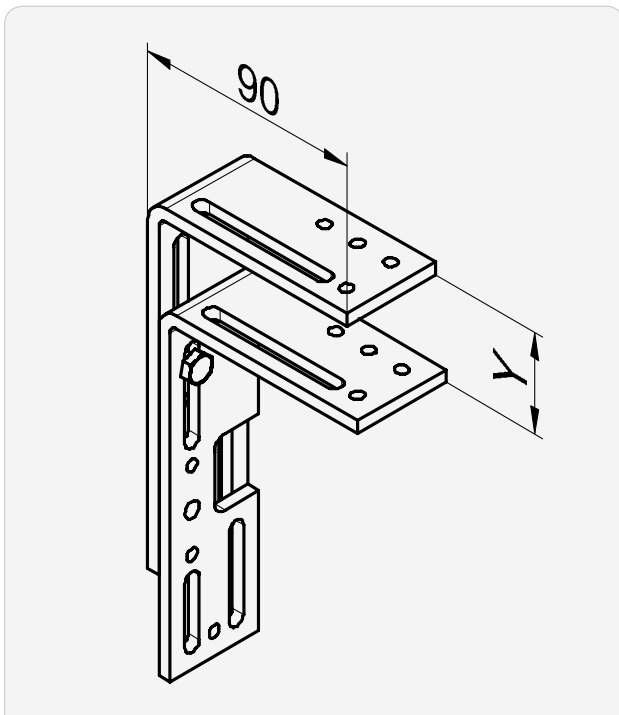

Gallery clip for type GB

i See additional documentation:
Short manual "Covers"



[↓ Covers](#)



Y

10... 75

75... 135

135... 200

Number of box supports

bk	Quantity
≤ 2000*	0
2001 ... 3000	1
3001 ... 4000	2
> 4000	3

* **bk ≤ 1500** with **motor > 9Nm**

Darkening

Vertical: Joint-covering profile

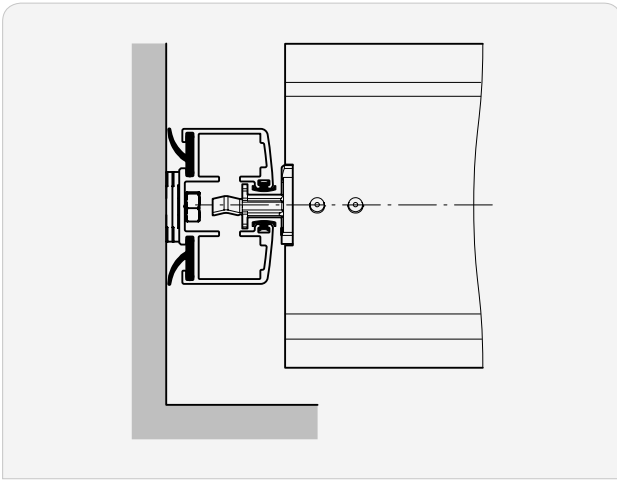

Horizontal: Double lip-seal

Situation A

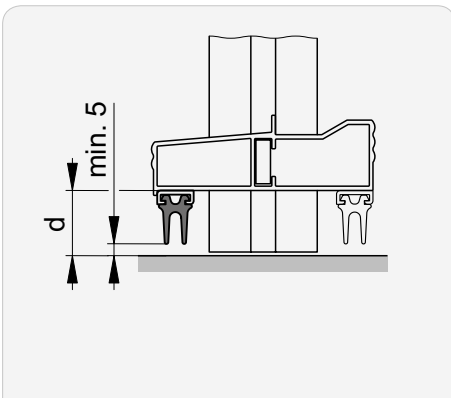

Situation B

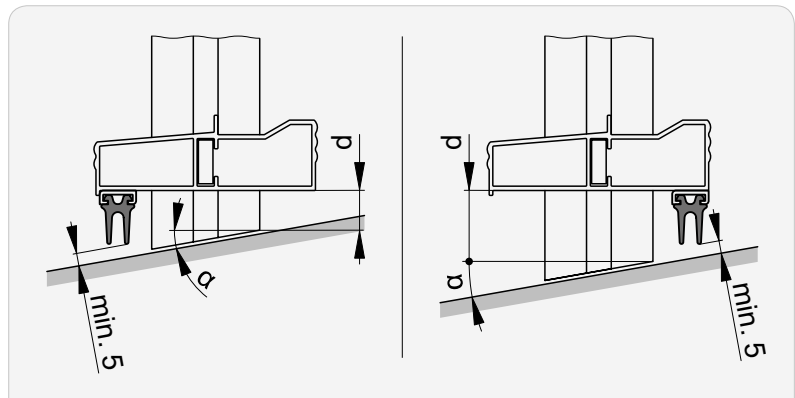

d
≥ 25

outside

α	d
1 ... 7	30
3 ... 12	25
8 ... 15	20
13 ... 15	15

inside

α	d
1 ... 8	30
1 ... 21	35
9 ... 32	40
21 ... 40	45
30 ... 46	50 (max.)
47 ... 60	–

Guide rail

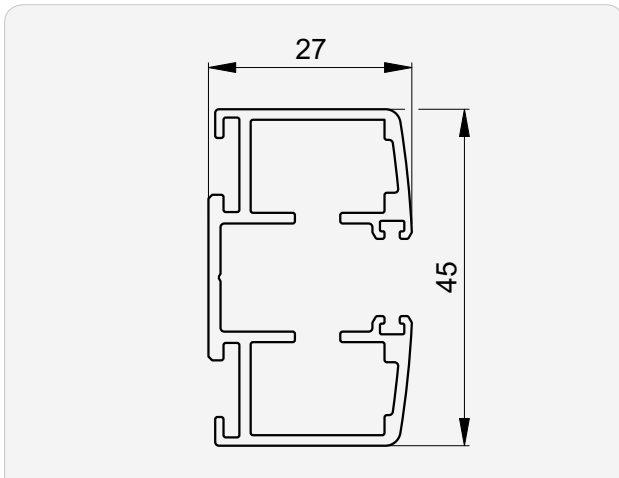

➔ Distance between guides FD	70	➔ Guide rail cut-outs in windowsill area.....	60
➔ Fastening points	65	➔ Installation window.....	64
➔ Guide extension and facet.....	59	➔ Integrated guides	53
➔ Guide rail fastenings	54		

Sections | Details

Horizontal section

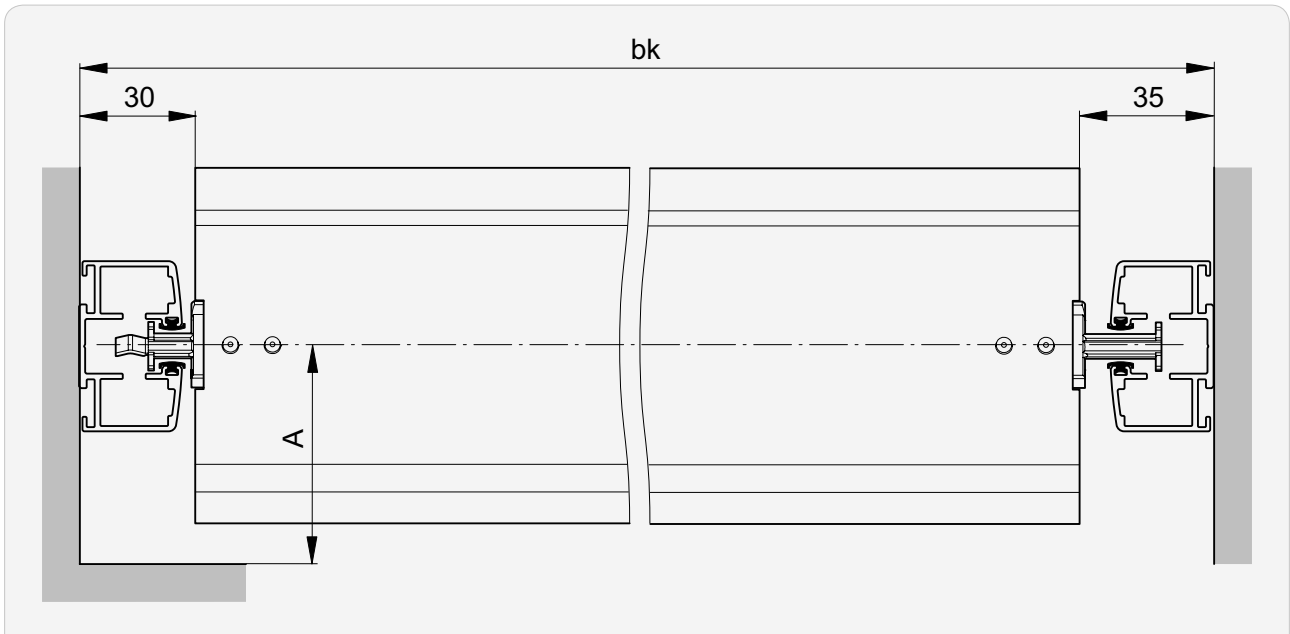

➔ Value for **A** 36

Detail for bottom

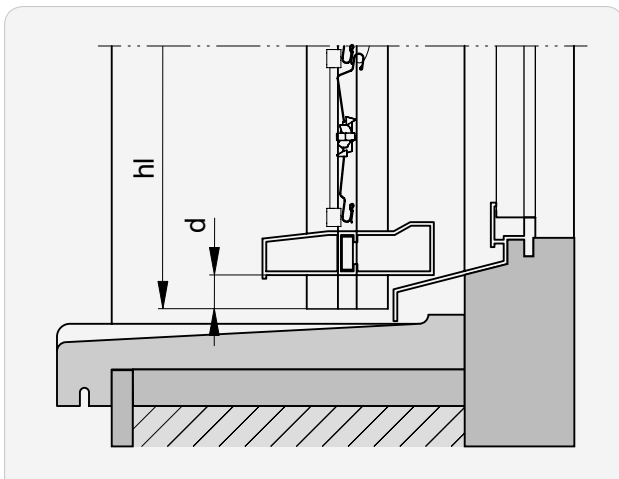

d (d-dimension)

5 ... 50 +5/-3

in 5 mm steps | Standard: 20

i **d-dimension** may vary with different blind dimensions.

Sections for crank drive (MBMA)

outside bk

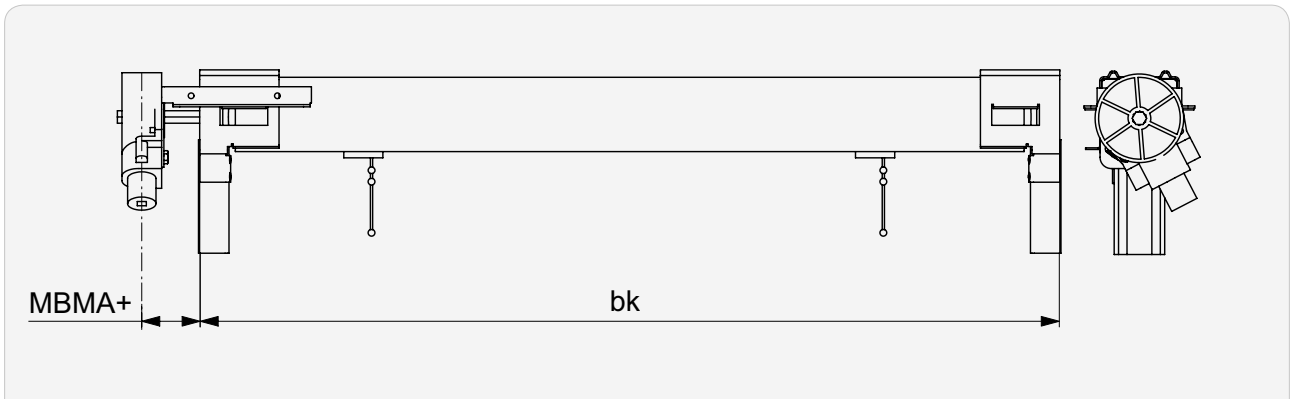

within bk

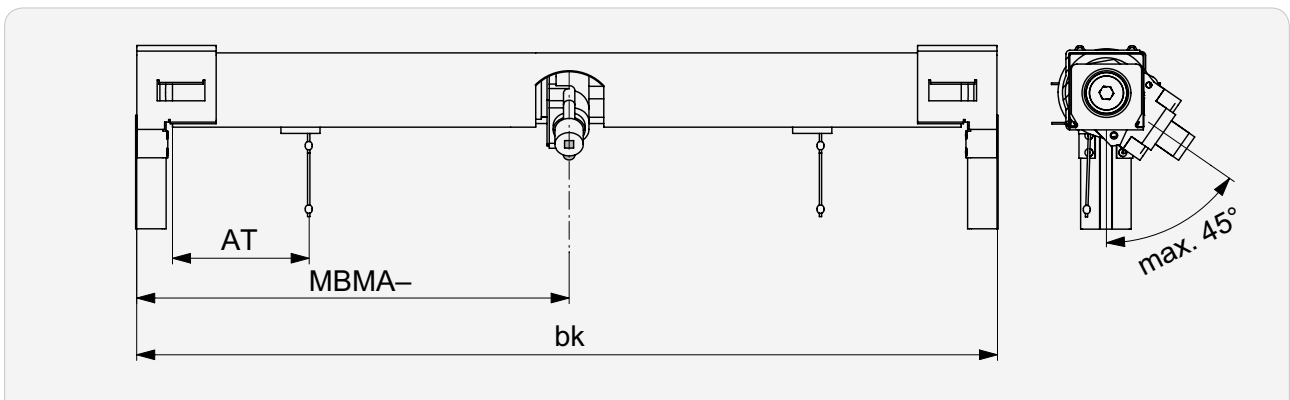

Version	MBMA+	MBMA-	Width max. (bk)	AT
without operating position	25 ... 100	95 + AT ... (bk/2)	≤ 750	100
			751 ... 1000	120
			> 1000	200
with operating position	25 ... 100	125 + AT ... (bk/2)	≤ 750	130
			751 ... 1000	130
			> 1000	200

Vertical connections | Standard motor position

Number of bearings

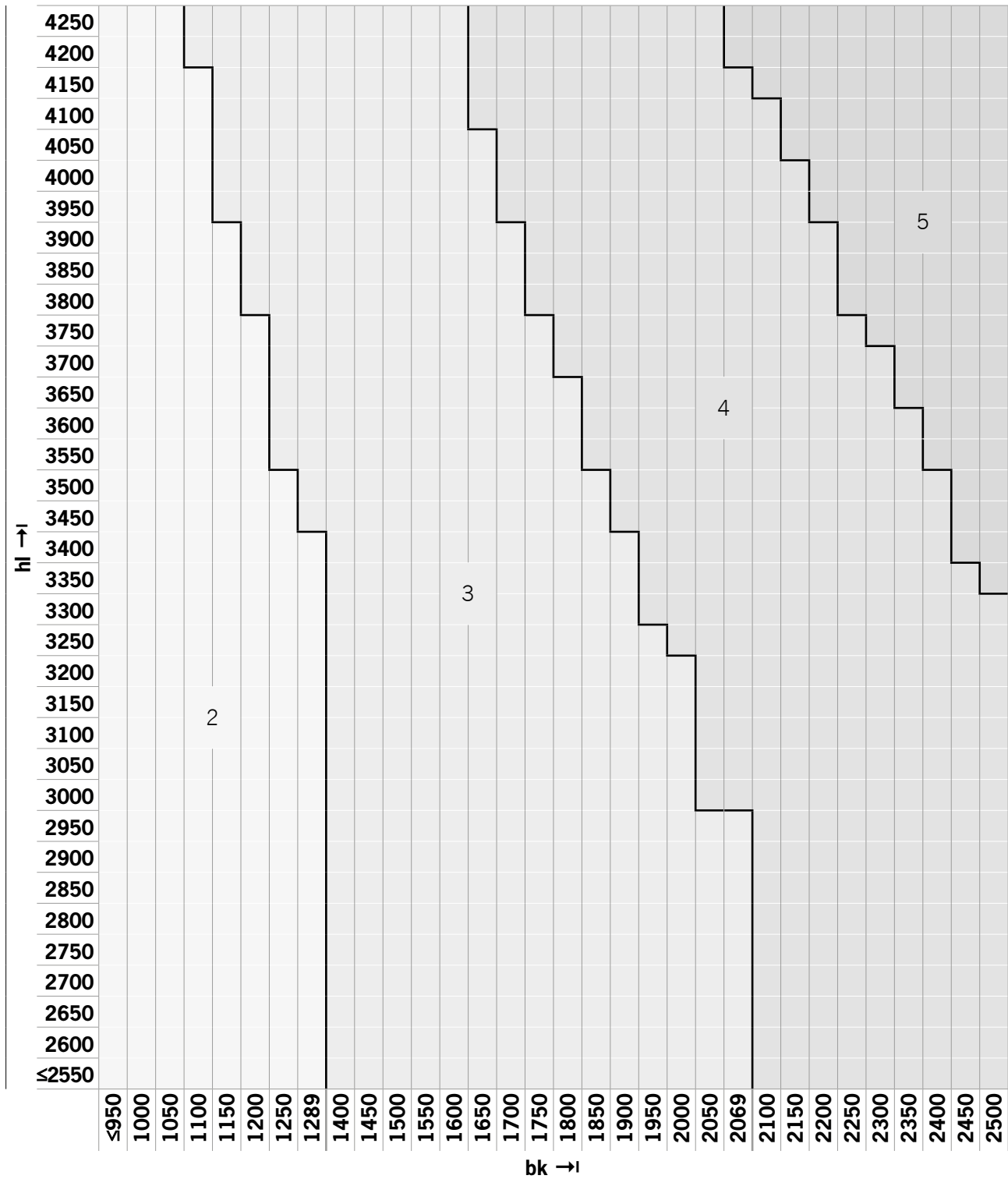

▶▶ Vertical connections | Standard motor position

Number of bearings

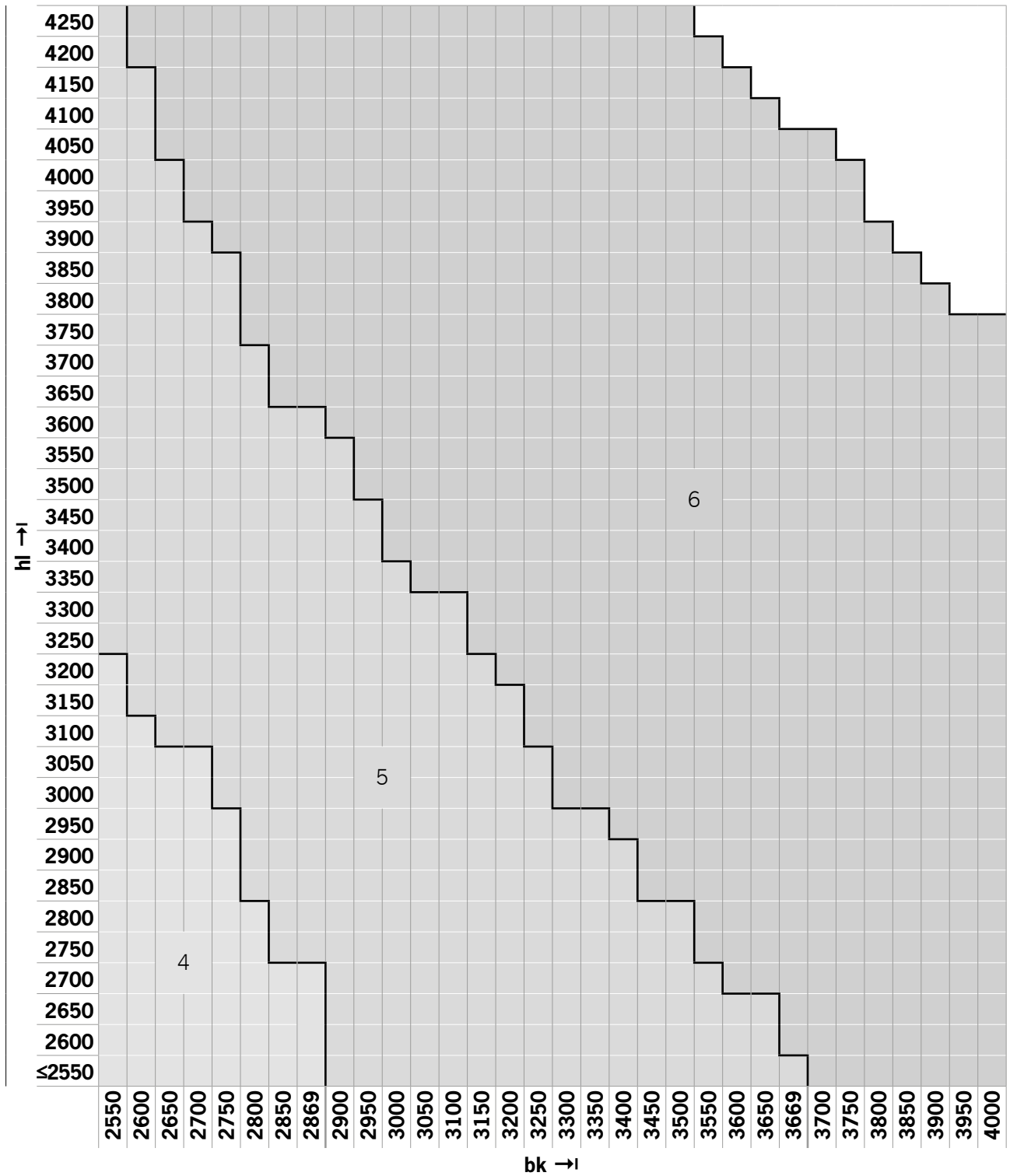

►► Vertical connections | Standard motor position

Number of bearings

Sinus

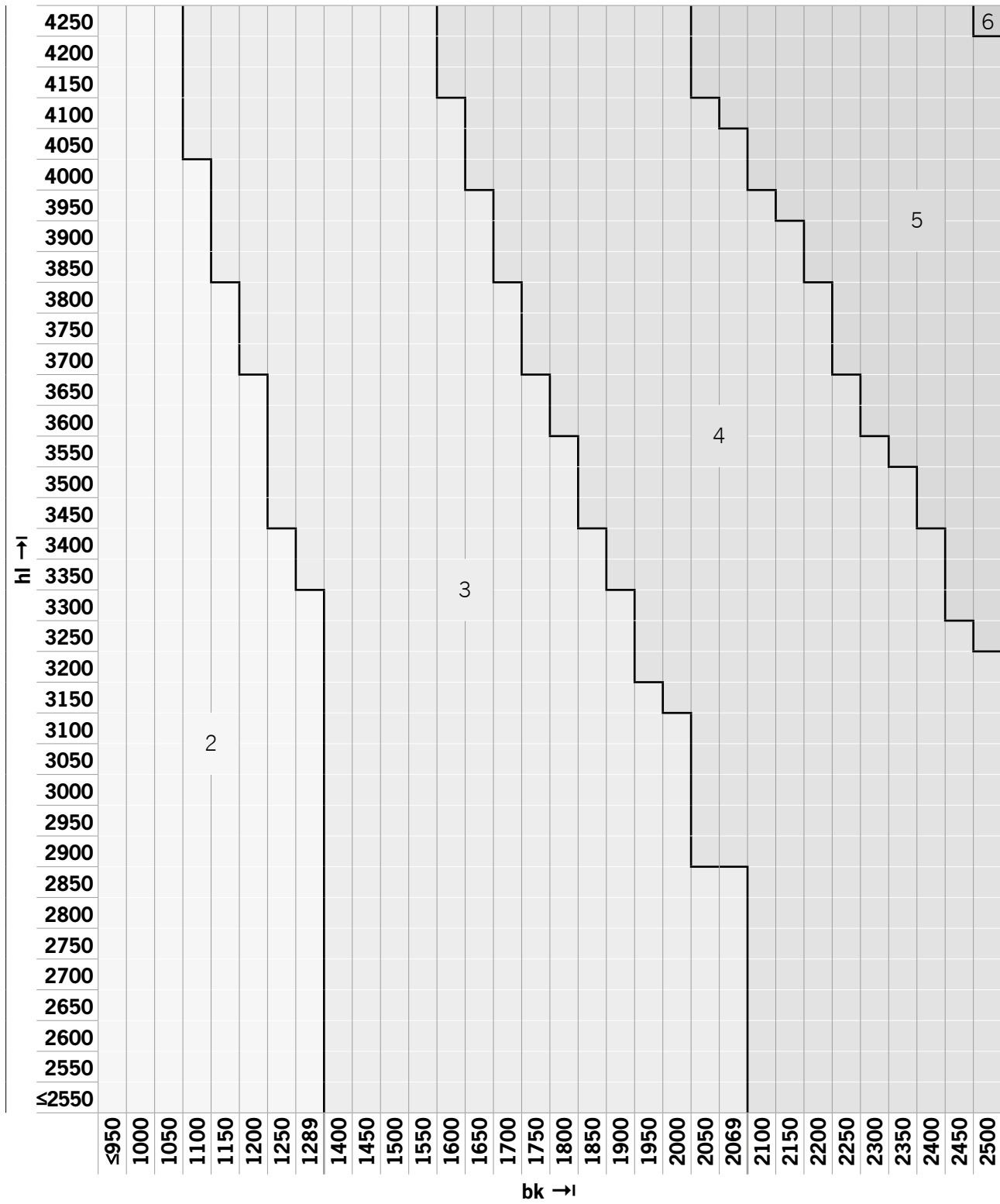

▶▶ Vertical connections | Standard motor position

Number of bearings

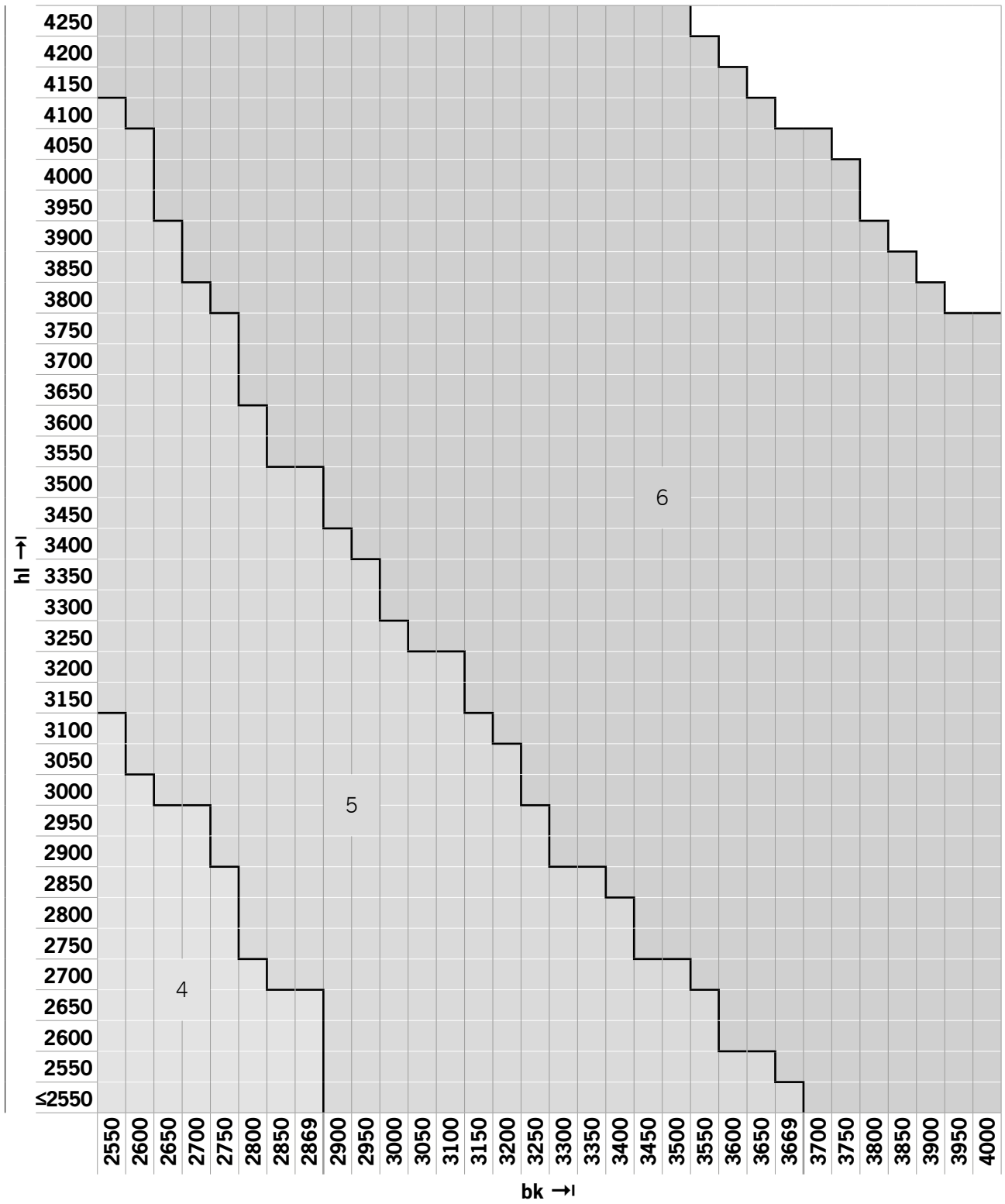

Sinus



▶▶ Vertical connections | Standard motor position

Standard motor position

Number of bearings	Standard motor position
2	
3	
4	
5	
6	

-  Bearing
-  Standard motor position
-  Possible motor position (on request)

Guide rail installation (principle)

Guides attached (to soffit) | Type A

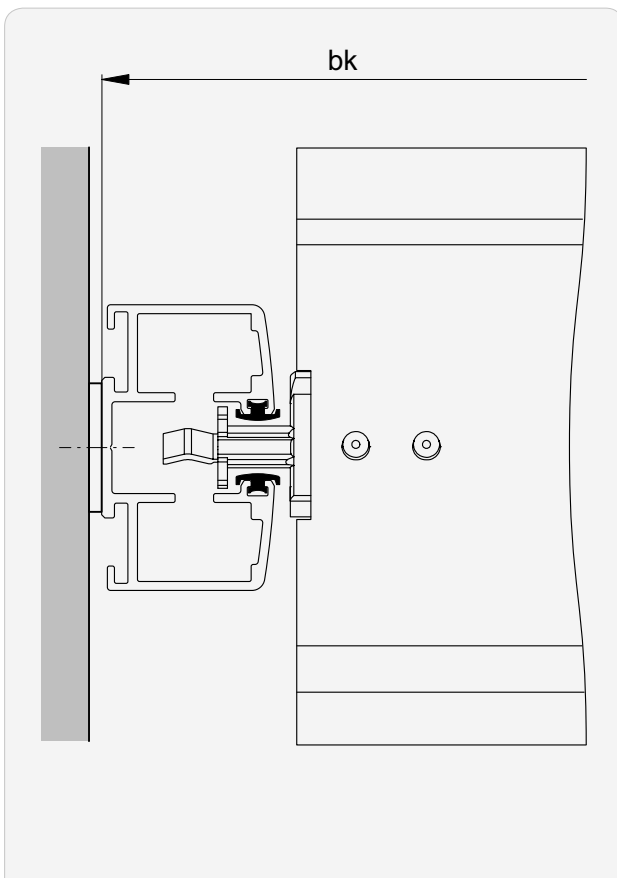

Guides suspended

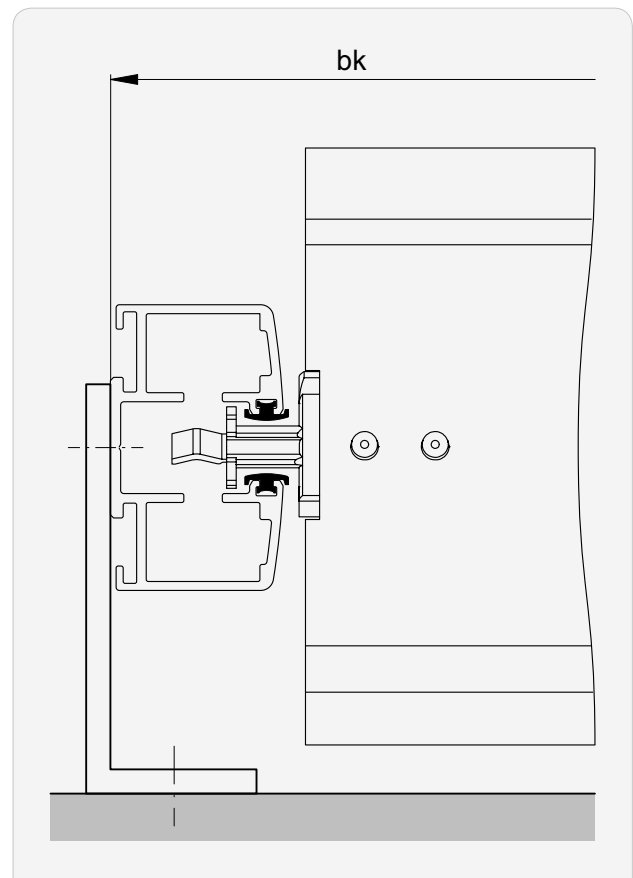

i Observe possible guide rail spacer for **bk**.
Standard: 2 mm

►► Guide rail installation (principle)

Guides recessed

! Two-part guides required!

i Only possible if $hl > 1135$

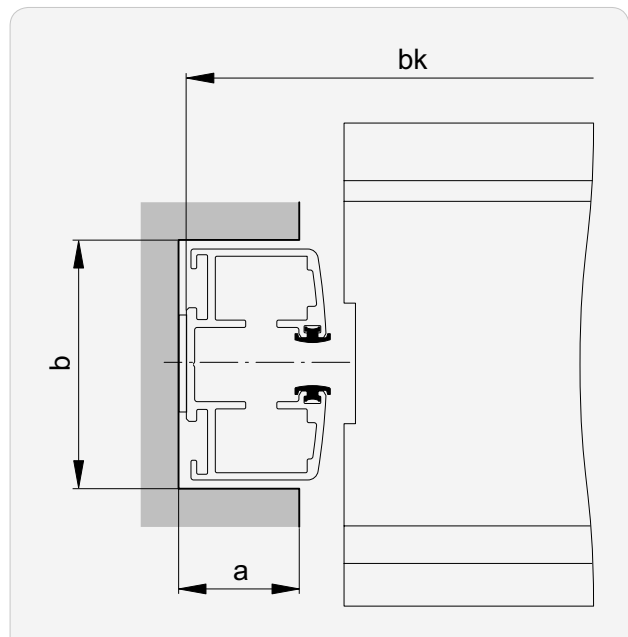
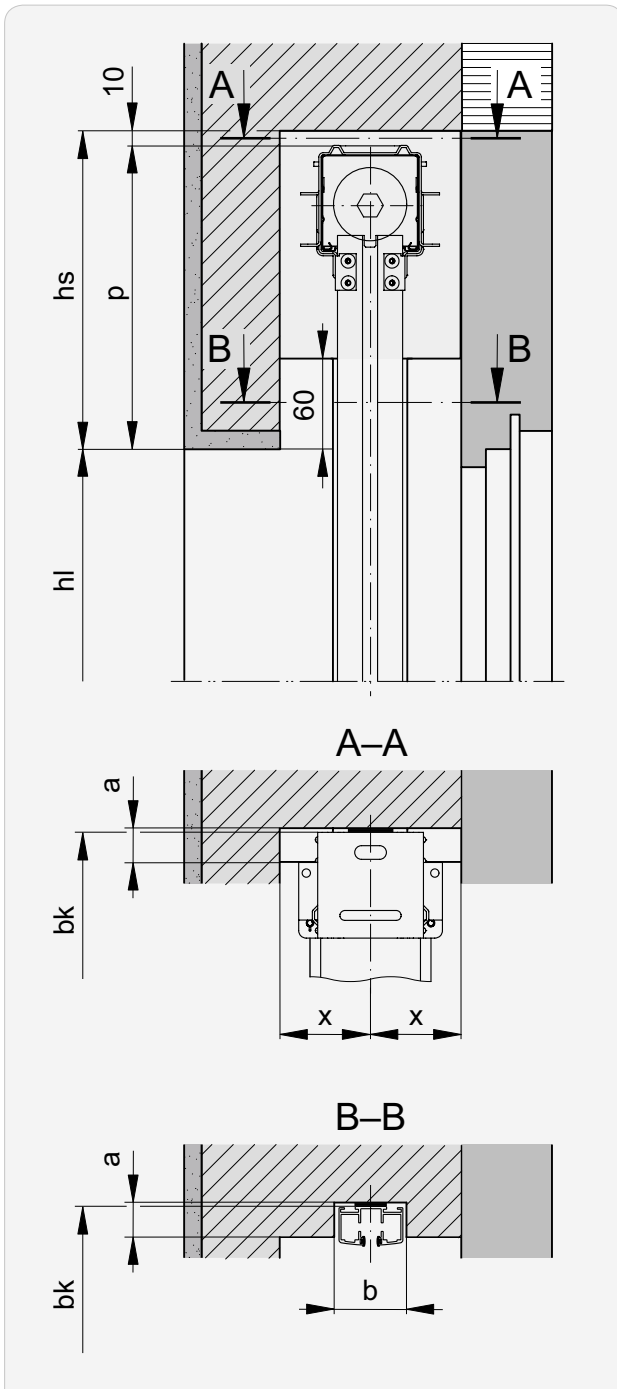

Version	x min.
Crank drive	60
Motor drive	

a	b
≤ 20	≥ 50

Guide rail fastenings (principle)

Overview

														Type	
A	B	Bd	C	Cd	E	F	G	H	Kv	M	T	Tv	V	Wv	
●	●	●	●	●	●	●	-	-	-	-	●	-	●	-	

- applicable without restrictions

A Soffit installation

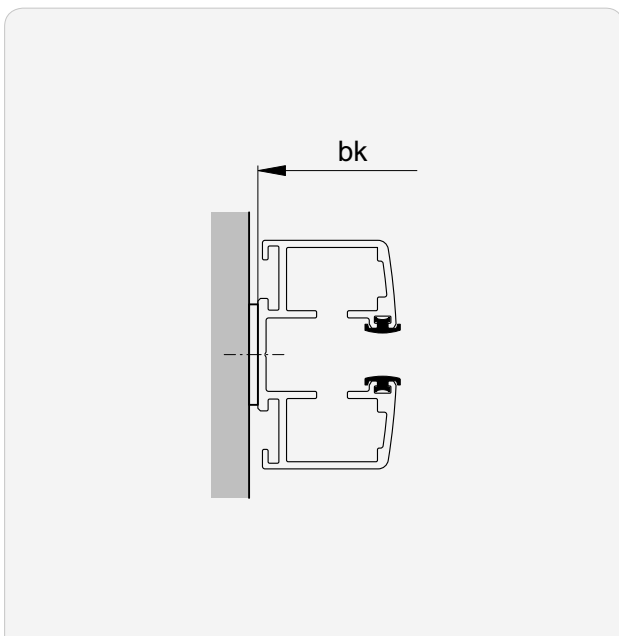

- i** Observe possible guide rail spacer for **bk**.
Standard: 2 mm

►► Guide rail fastenings (principle)

B Installation with fastening bracket

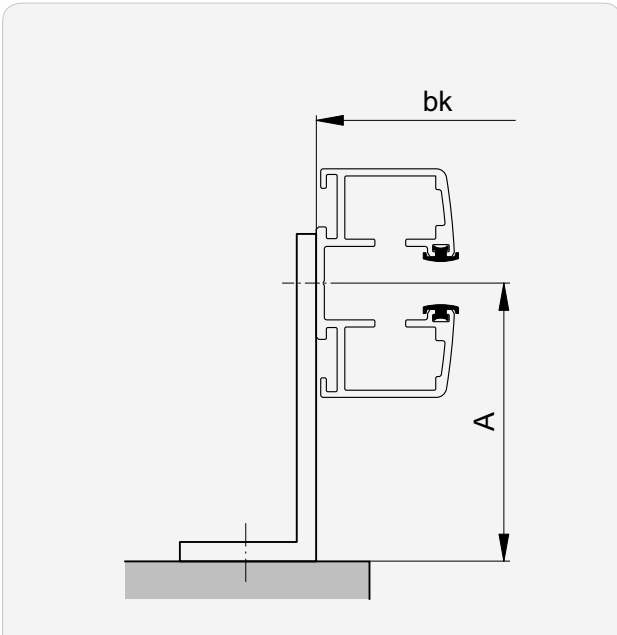

Bracket outwards

C Installation with fastening bracket

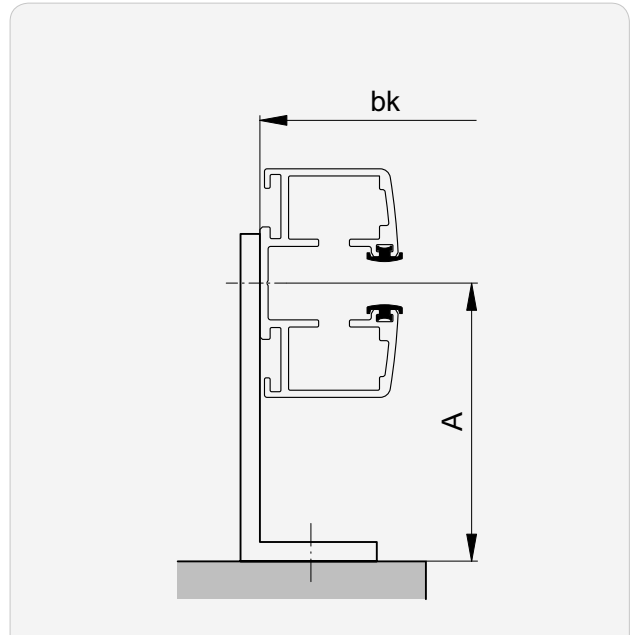

Bracket inwards

Fastening bracket for types B and C

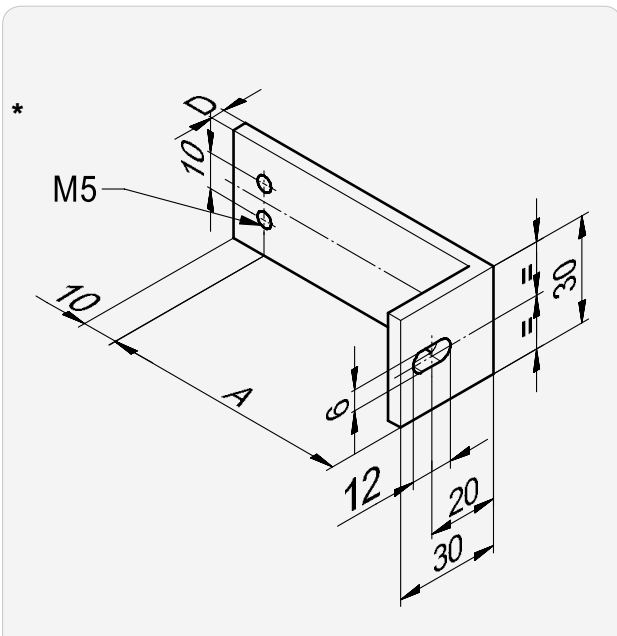

A*	D
20... 115	4

Fastening bracket 70mm for types B and C

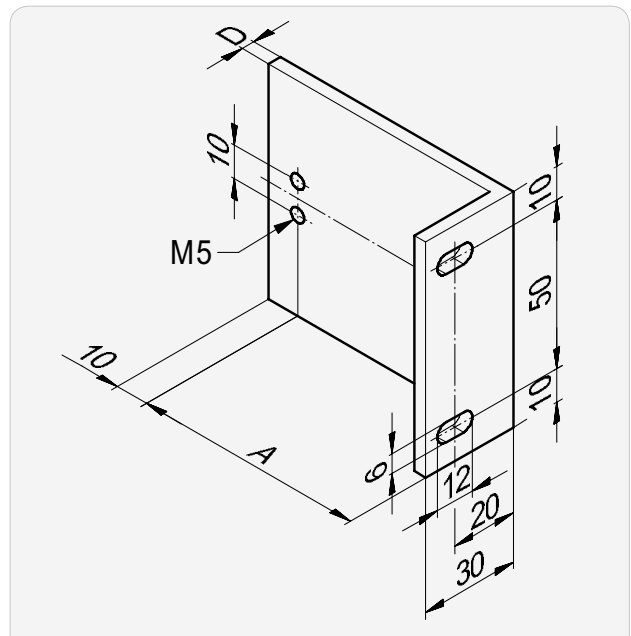

A*	D
20... 115	4
120... 215	5

i For suspended guide rails always with **brackets 70mm**.

i If the **projection is ≥ 120**, all products are fastened with a **70mm bracket**.

* in 5 mm steps

►► Guide rail fastenings (principle)

Bd Installation with continuous fastening bracket

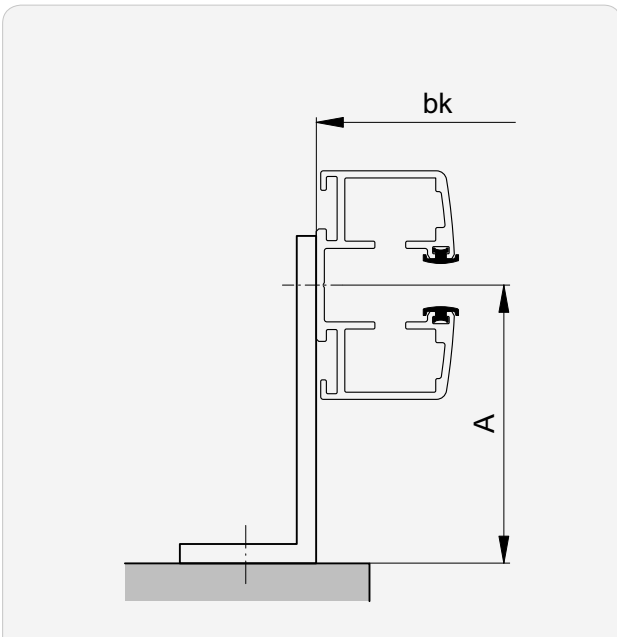

Bracket outwards

Cd Installation with continuous fastening bracket

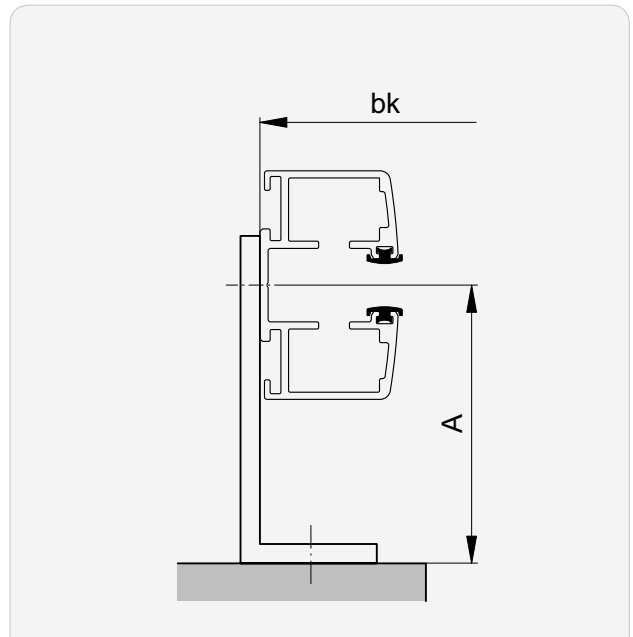

Bracket inwards

Continuous fastening bracket for types Bd and Cd

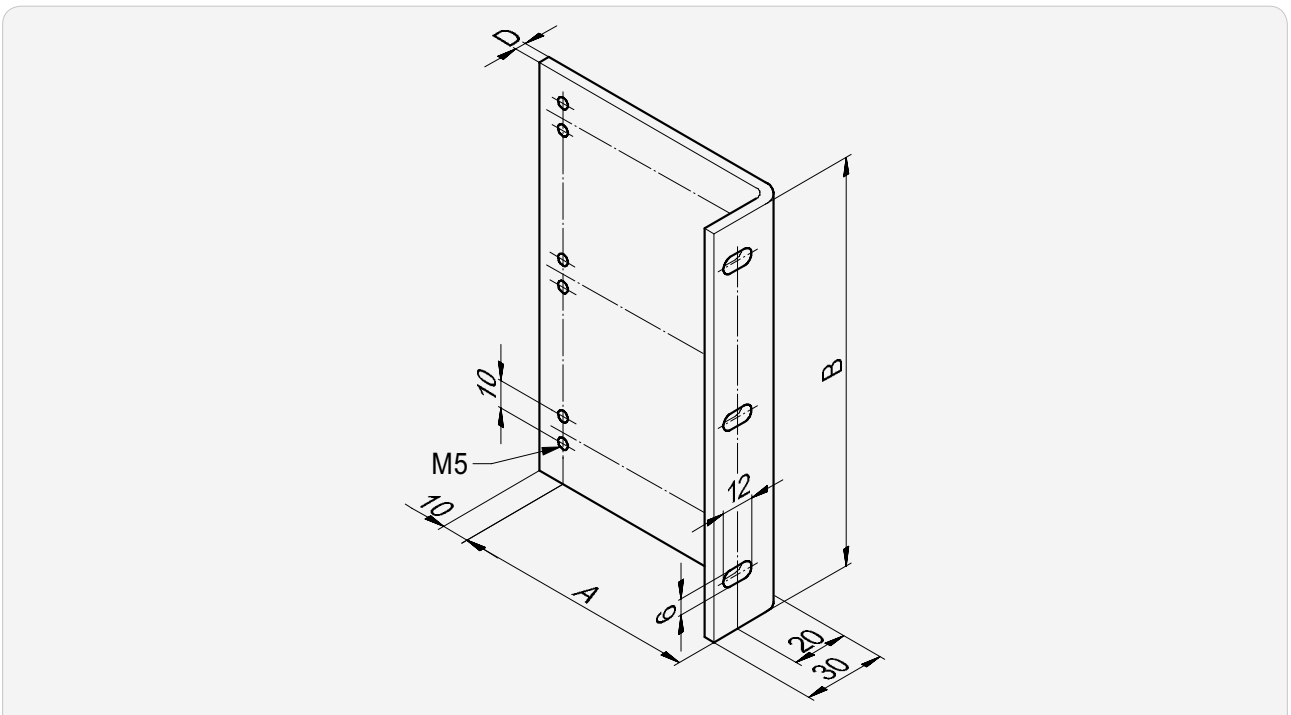

A*
20...300

D
always 4

* in 5 mm steps

►► Guide rail fastenings (principle)

E|F Installation with fastening lug

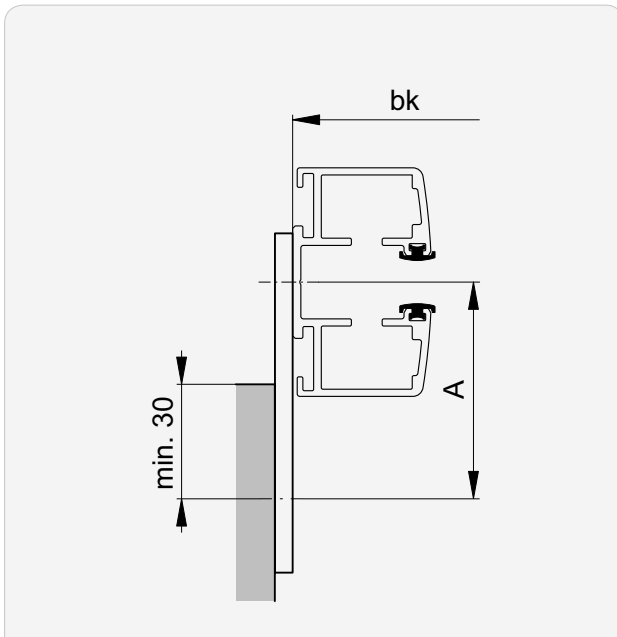

inwards / outwards

T Installation with T-bracket

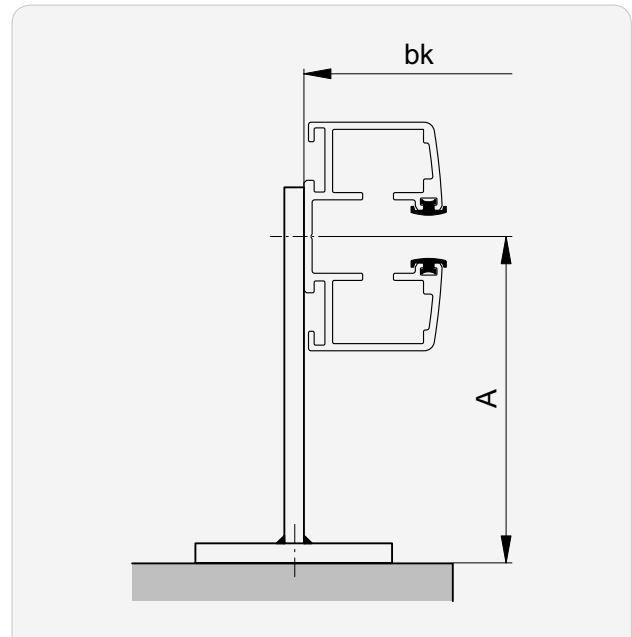

Fastening lug for type E | F

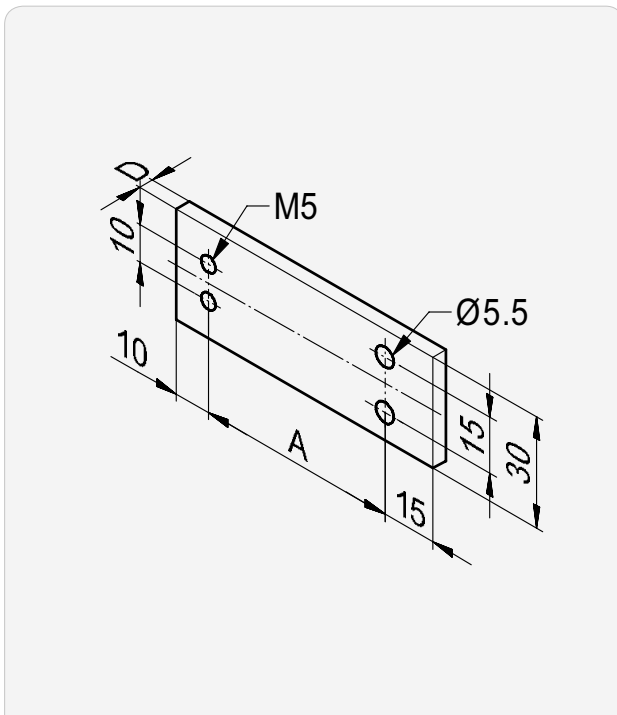

A*	D
50... 115	4
120... 125	5

T-bracket for type T

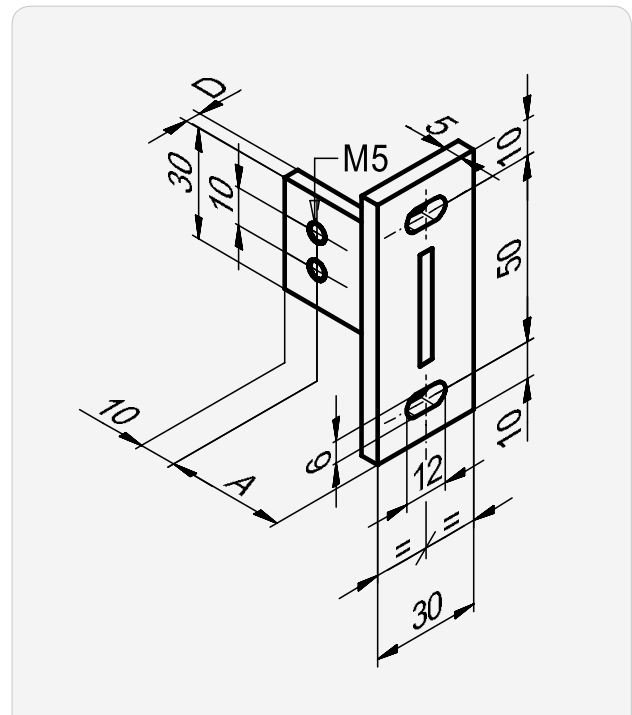

A*	D
20... 115	4
120... 215	5

* in 5 mm steps

▶▶ Guide rail fastenings (principle)

V Installation with one bracket

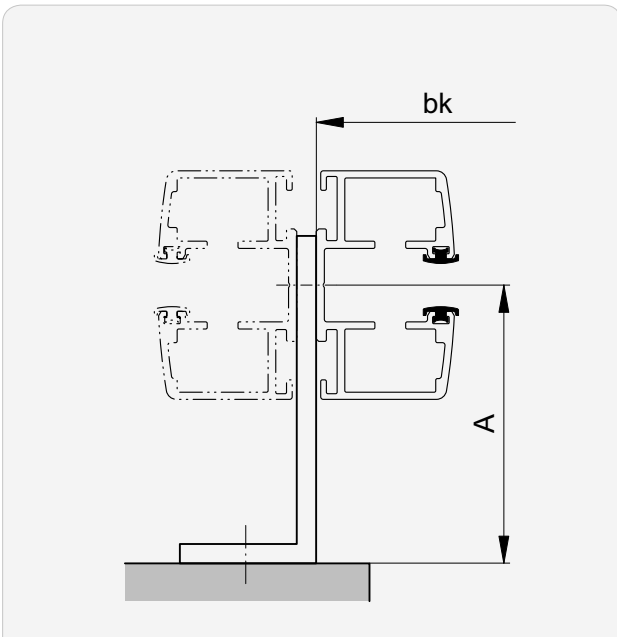

The blind on the right uses the fastening for the blind on the left.

Guide extension and facet

Extension and facet

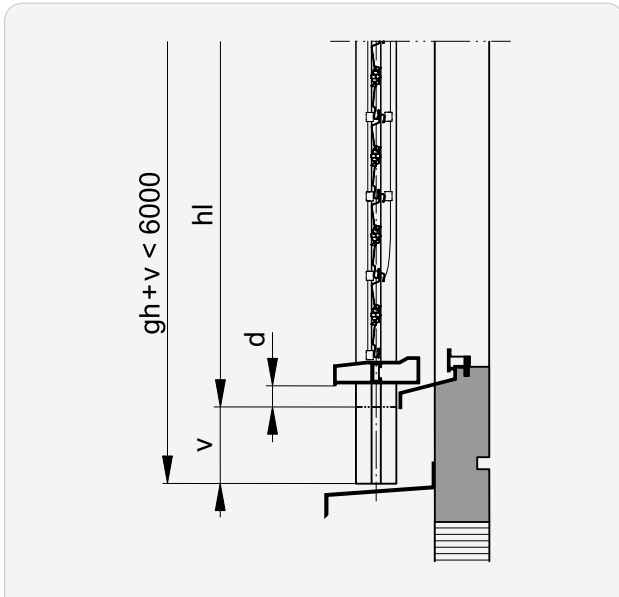

v
0 ... 3000

Facet

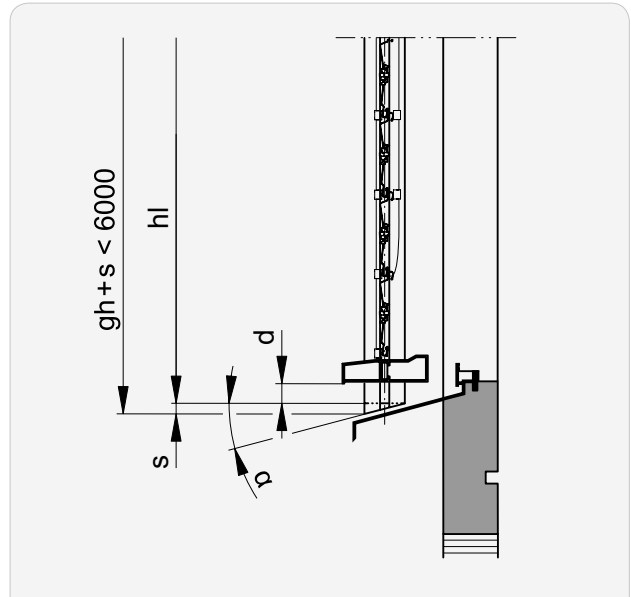

α
5 ... 60°

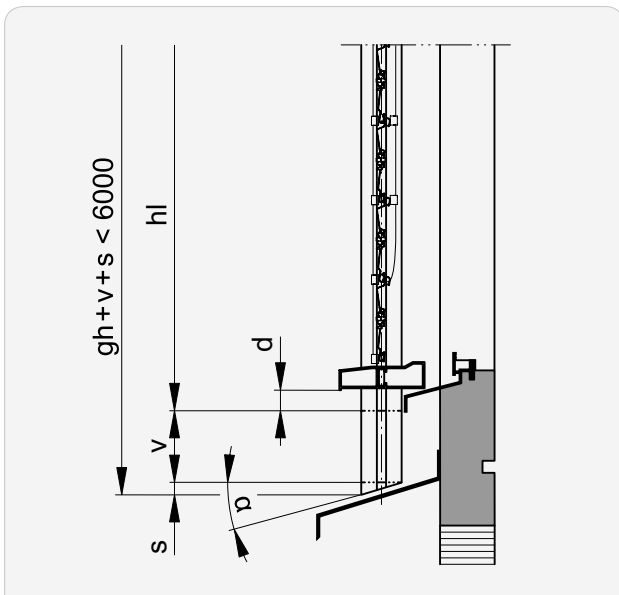

v
0 ... 3000

α
5 ... 60°

Angling at the guides

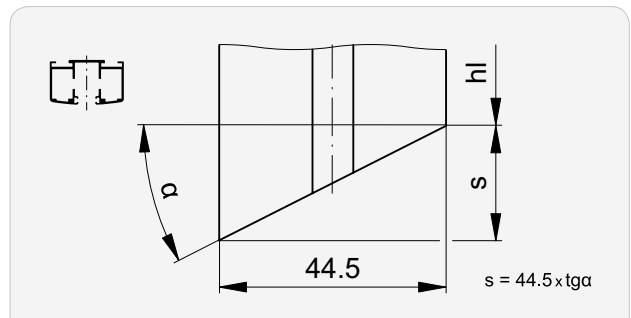

α	s	α	s	α	s	α	s	α	s
5	4	15	12	25	21	35	31	45	45
6	5	16	13	26	22	36	32	46	46
7	5	17	14	27	23	37	34	47	48
8	6	18	14	28	24	38	35	48	49
9	7	19	15	29	25	39	36	49	51
10	8	20	16	30	26	40	37	50	53
11	9	21	17	31	27	41	39	51	55
12	9	22	18	32	28	42	40	52	57
13	10	23	19	33	29	43	41	53	59
14	11	24	20	34	30	44	43	54	61

Guide rail cut-outs in windowsill area

Rear cut-out | without/with extension

Without extension

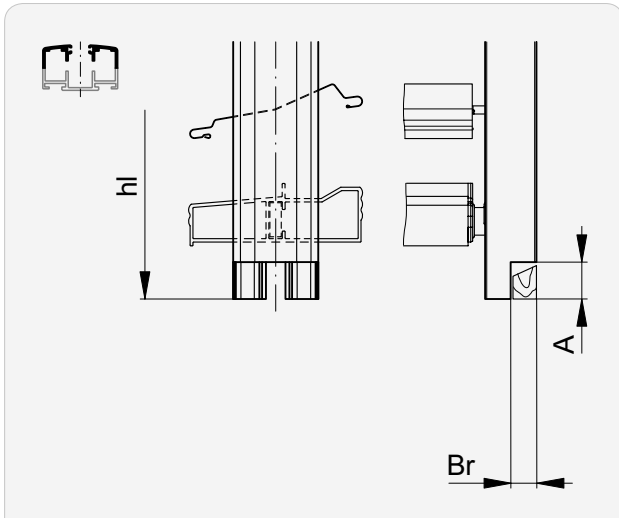

A	Br
≤ d-dimension	2 ... 4 6 ... 15

Extension | $v \leq A$

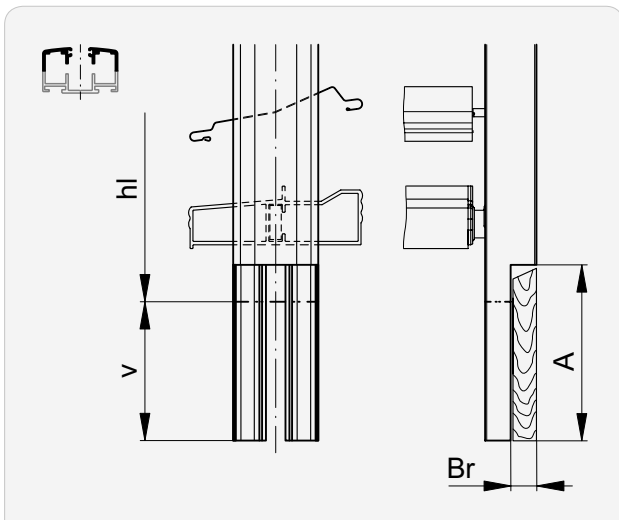

A	Br
≤ d-dimension	2 ... 4 6 ... 15

Extension | $v > A$

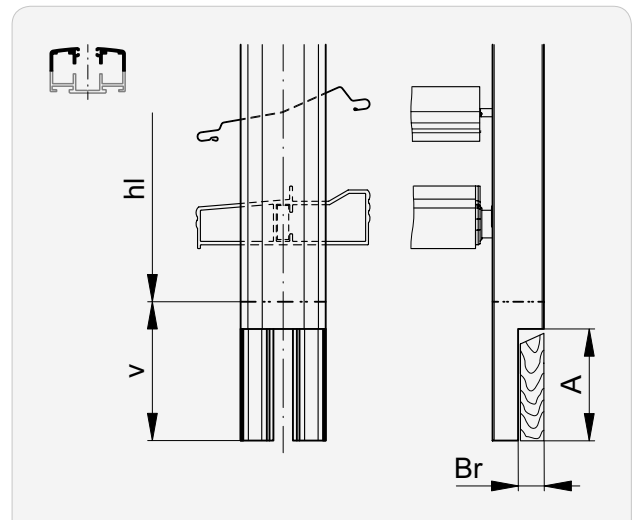

A	Br
≤ d-dimension	2 ... 4 6 ... 15

v Guide rail extension: 0 ... 3000

 **d-dimension** 45

►► Guide rail cut-outs in windowsill area

Rear cut-out | with facet/with extension and facet

Facet

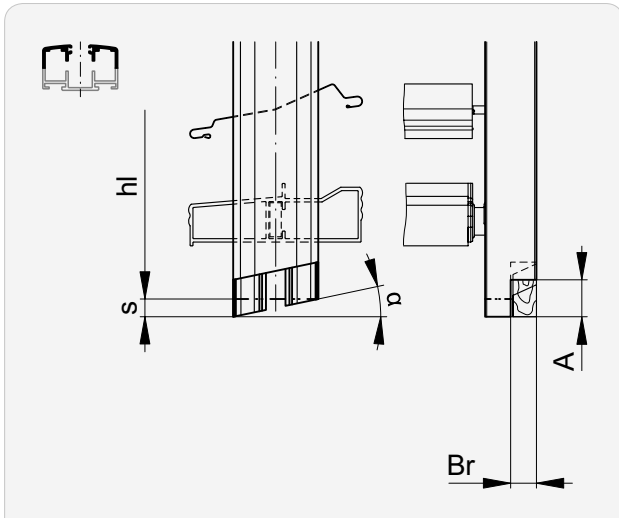

A	Br
≤ d-dimension (5...35)	2...4
	6...15

Extension and facet | $(v + s) \leq A$

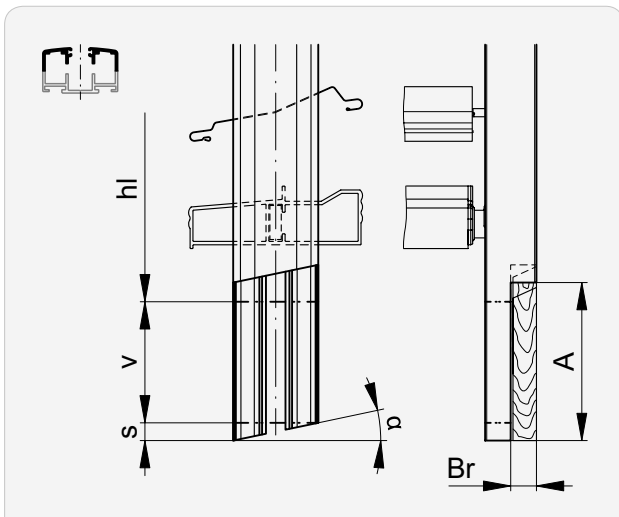

A	Br
≤ d-dimension (5...35)	2...4
	6...15

Extension and facet | $(v + s) > A$

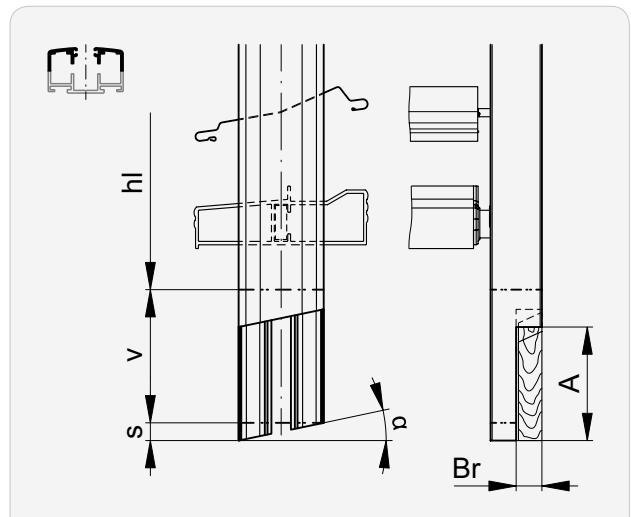

A	Br
≤ d-dimension (5...35)	2...4
	6...15

v Guide rail extension: 0...3000

➡ d-dimension 45

▶▶ Guide rail cut-outs in windowsill area

Inner cut-out | without/with extension

Without extension

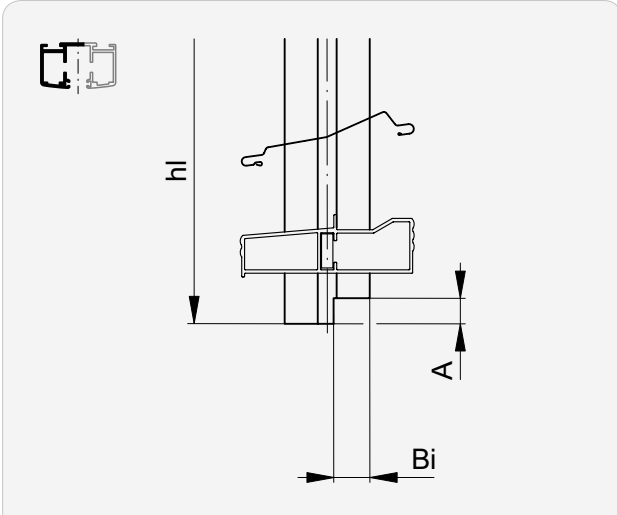

A	Bi
≤ d-dimension	0... 13
	19

Extension | $v \leq A$

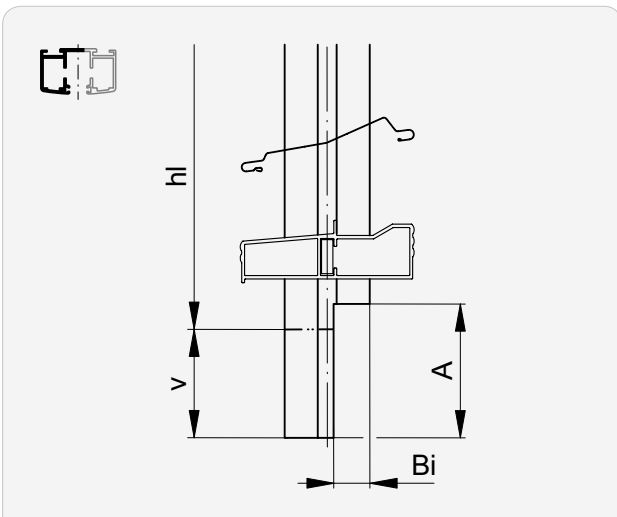

A	Bi
≤ d-dimension	0... 13
	19

Extension | $v > A$

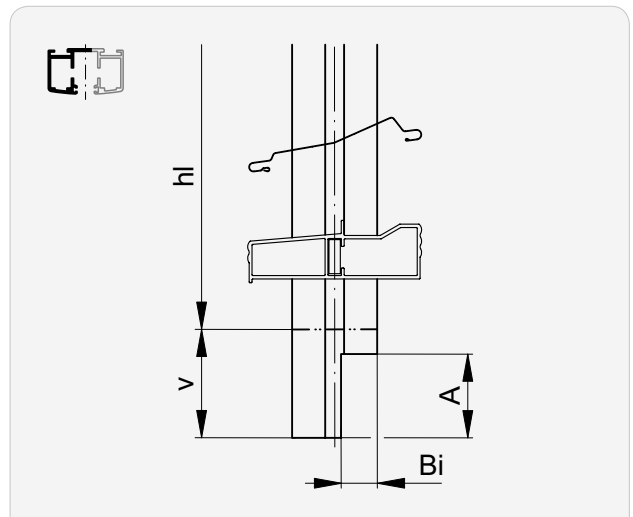

A	Bi
≤ d-dimension	0... 13
	19

v Guide rail extension: 0... 3000

►► Guide rail cut-outs in windowsill area

Inner cut-out | with facet/with extension and facet

Facet

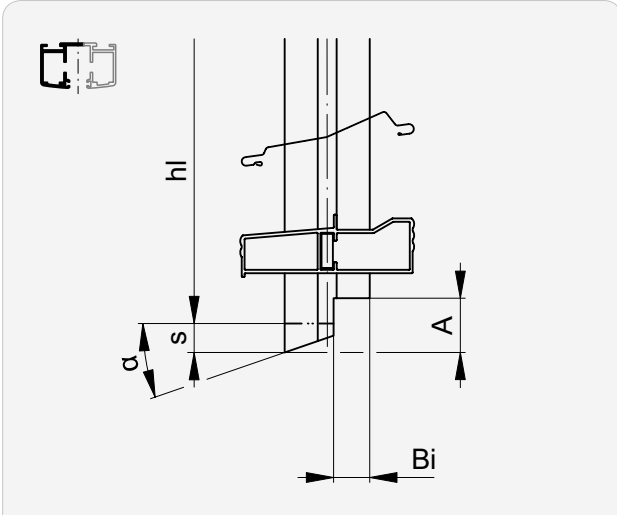

A	Bi
≤ d-dimension	0... 13
	19

Extension and facet | $(v + s) \leq A$

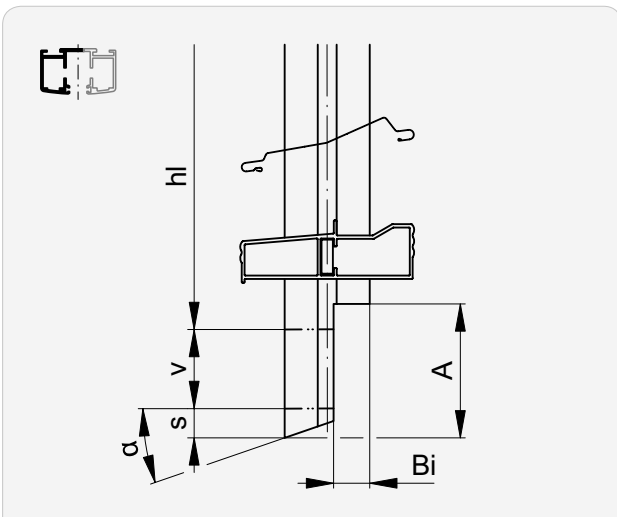

A	Bi
≤ d-dimension	0... 13
	19

Extension and facet | $(v + s) > A$

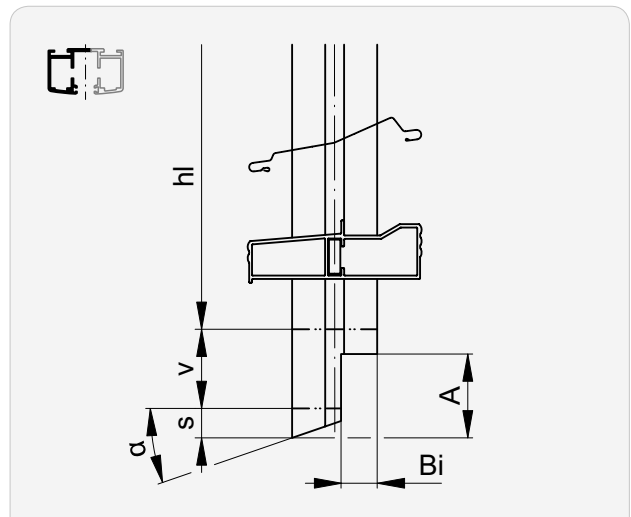

A	Bi
≤ d-dimension	0... 13
	19

v Guide rail extension: 0... 3000

➡ d-dimension 45

Installation window

Without extension

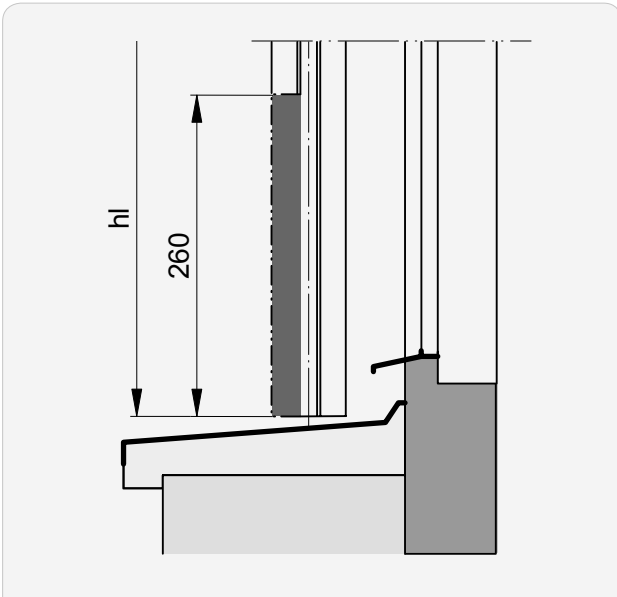

With extension

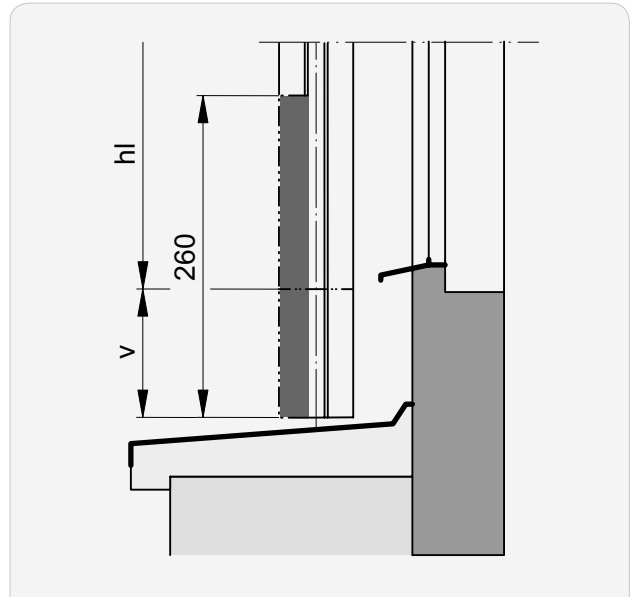

With extension and facet

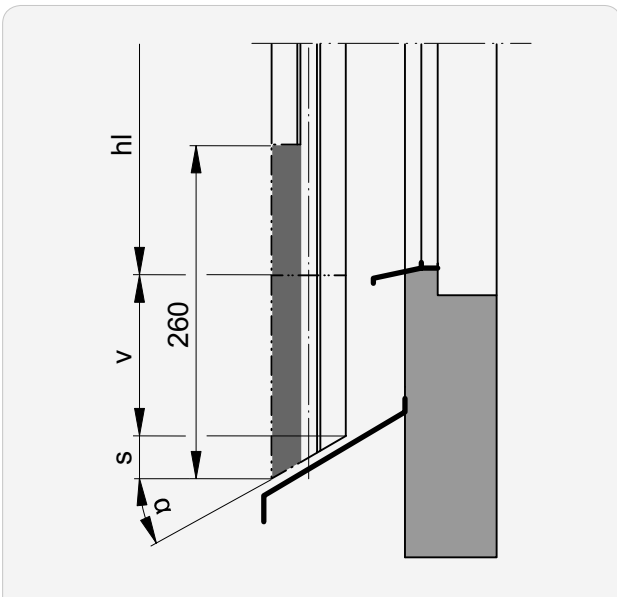

for $(v + s) \leq 80$

always for
bottommost

for $(v + s) > 80$

two-part guide rails instead of installation window ($hl > 1135$)
always with continuous beading.

s Faceting (guide rail width x $\tan \alpha$)

v Guide rail extension: max. 1000

Fastening points

Without extension

Z	AS
≤ 1500	2
1501 ... 2700	3
2701 ... 3900	4
3901 ... 5100	5
> 5100	6

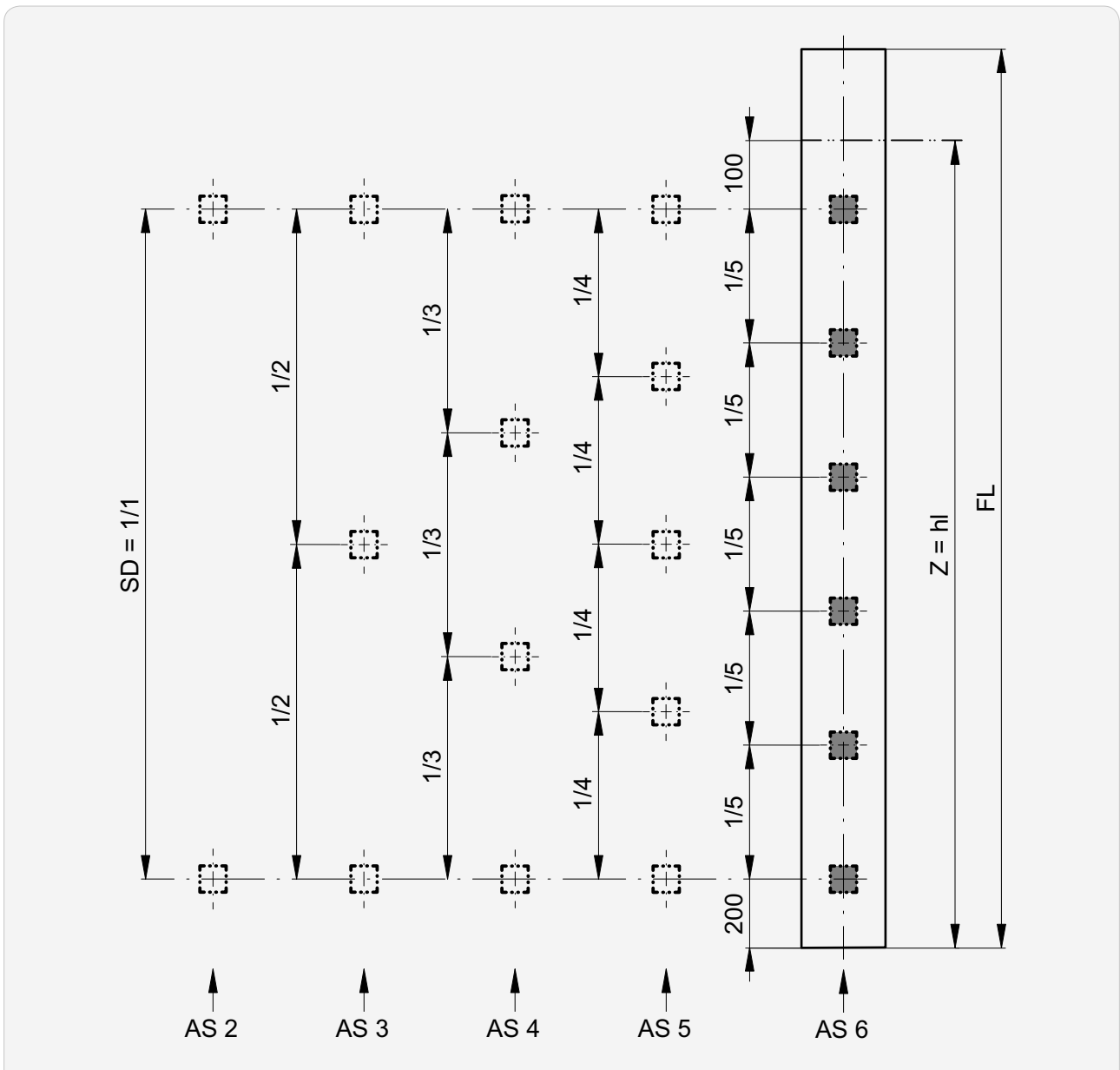

AS Number of slits

SD Slot spacing: max. 1200

i Bottommost fastening point at the same time as fastening point for installation window.

➔ Guide rail fastenings 54

➔ Installation window..... 64

►► Fastening points

With guide rail extension

Z	AS
≤ 1500	2
1501 ... 2700	3
2701 ... 3900	4
3901 ... 5100	5
> 5100	6

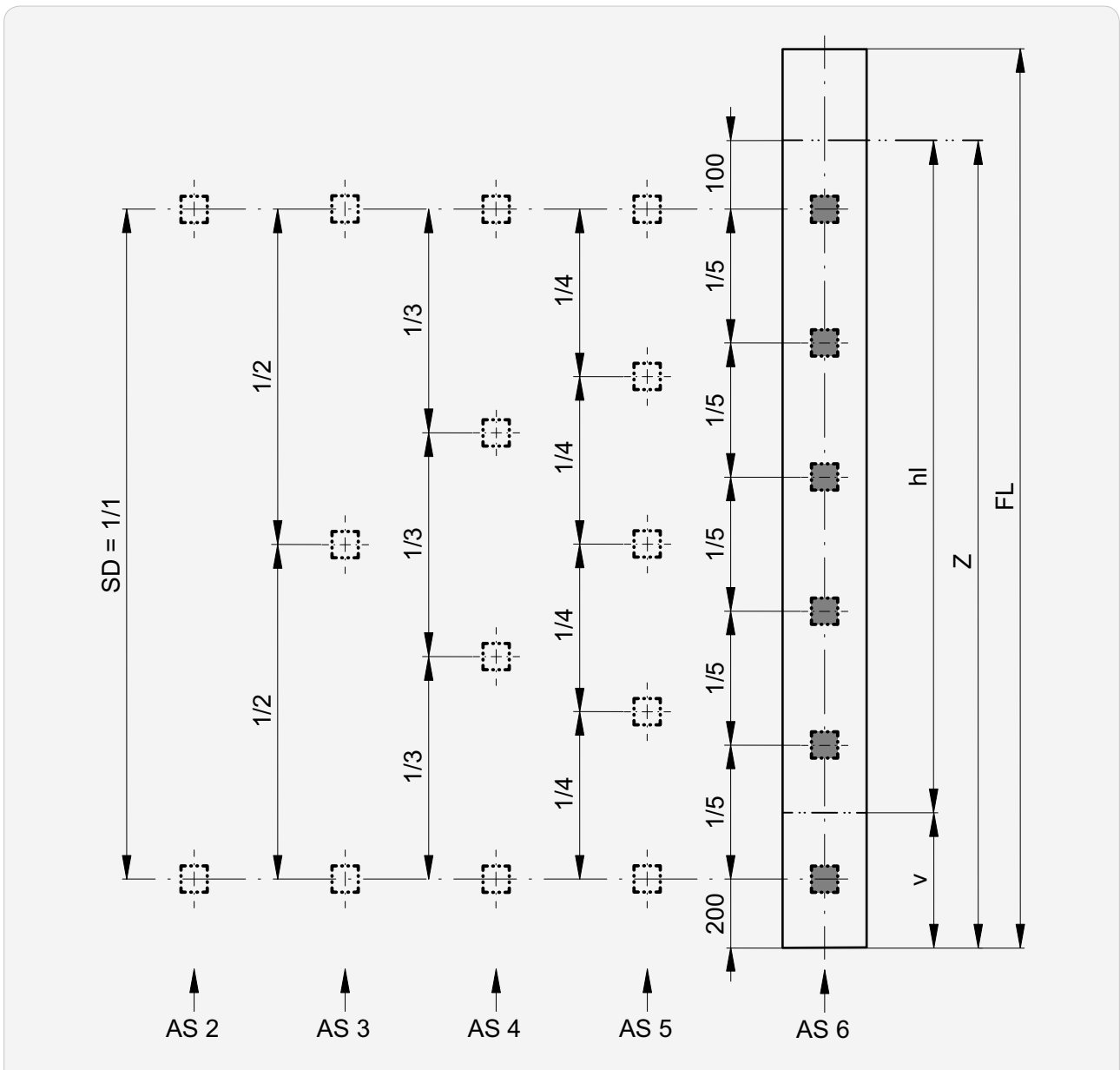

AS Number of slits
SD Slot spacing: max. 1200

v Guide rail extension: max. 1000

- ➡ Guide extension and facet 59
- ➡ Installation window 64
- ➡ Guide rail fastenings 54

►► Fastening points

With facet

Z	AS
≤ 1500	2
1501 ... 2700	3
2701 ... 3900	4 </td
3901 ... 5100	5
> 5100	6

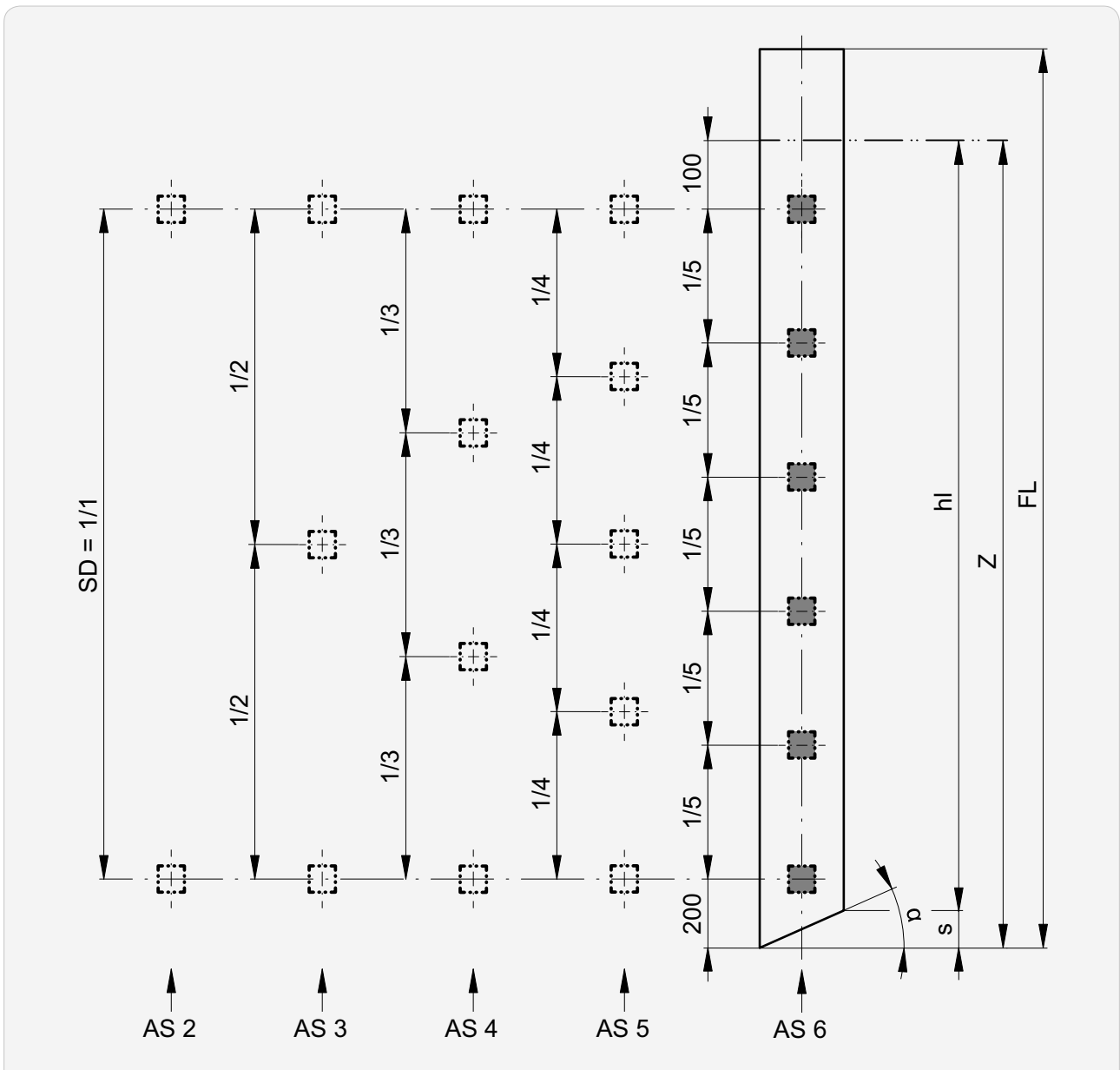

AS Number of slits

SD Slot spacing: max. 1200

s Faceting (guide rail width x tgα)

► Guide extension and facet 59

► Guide rail fastenings 54

► Installation window 64

►► Fastening points

With guide rail extension and facet

Z	AS
≤ 1500	2
1501 ... 2700	3
2701 ... 3900	4
3901 ... 5100	5
> 5100	6

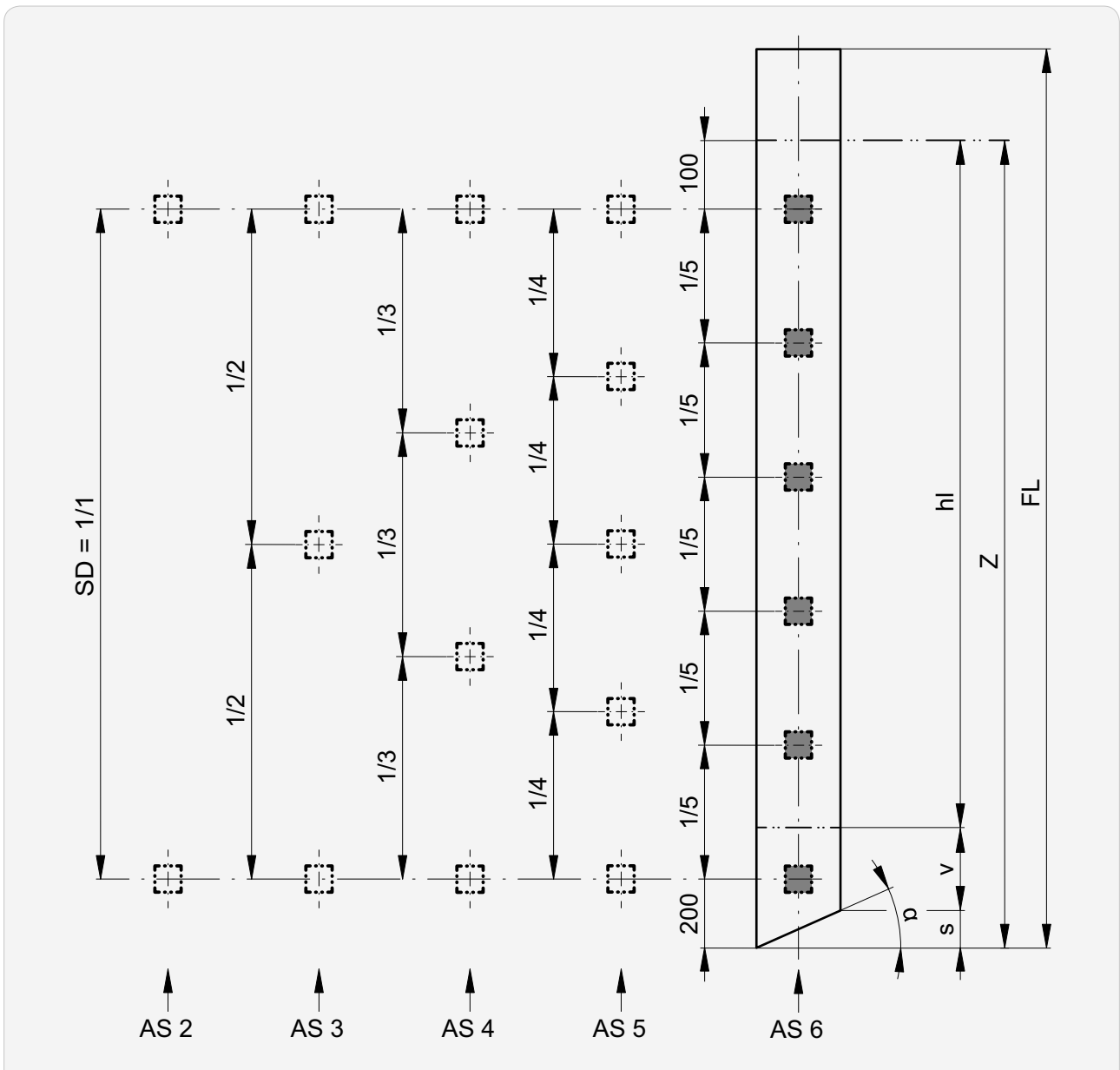

AS Number of slits

s Faceting (guide rail width x tgα)

SD Slot spacing: max. 1200

v Guide rail extension: max. 1000

► Guide extension and facet 59

► Guide rail fastenings 54

► Installation window 64

►► Fastening points

For two-part guide rails

FLUT	for (s+v) ≤ 80 hl*	for (s+v) > 80 s+v	ASOT	hl*
500	≤1635	81 ... 250	2	≤2582
1000	1636 ... 1885	251 ... 750	3	2583 ... 3782
1250	≥1886	≥751	4	≥3783

* hl > 1135: always with continuous beading.

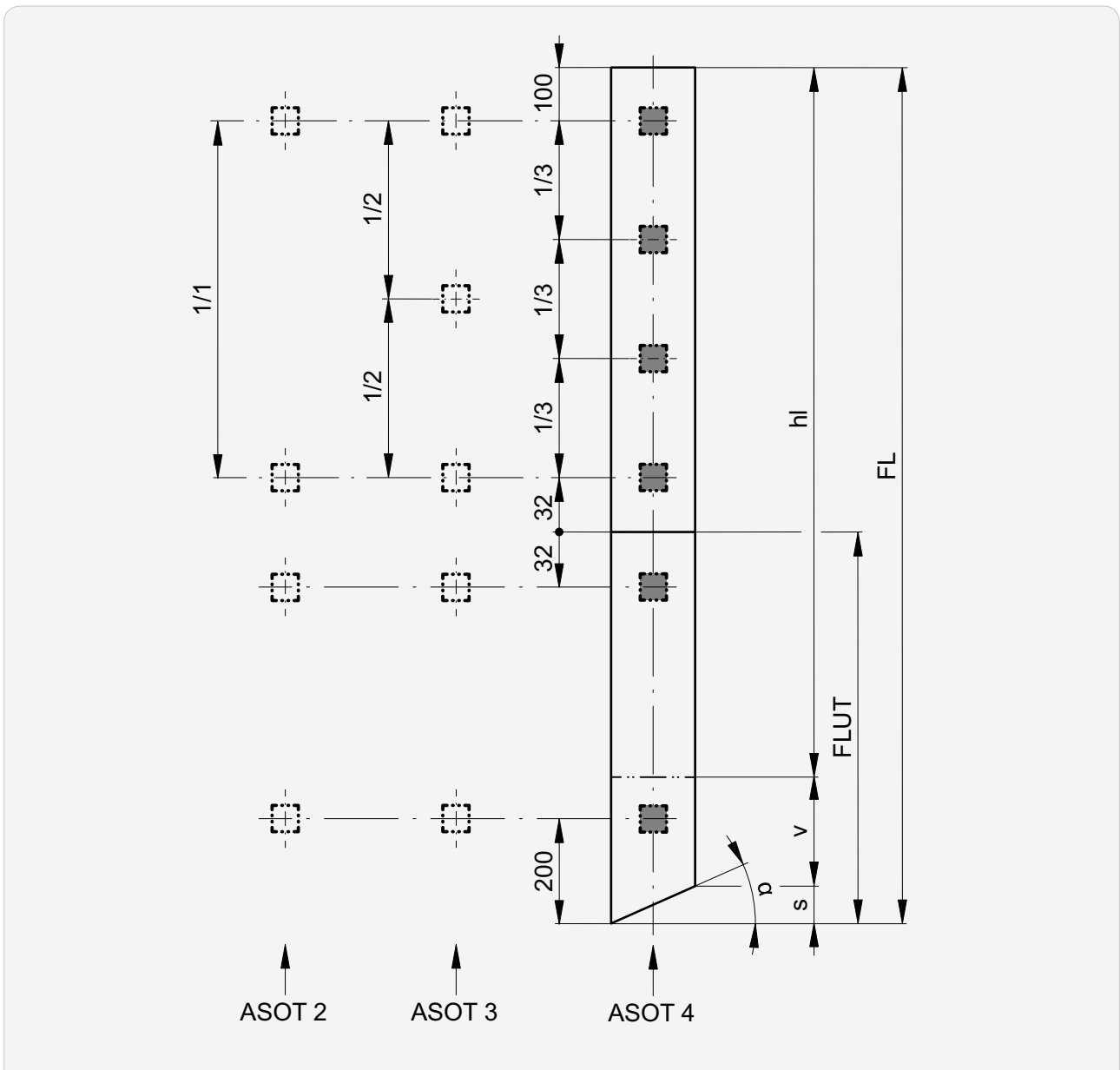

ASOT Number of slits in top part

FLUT Length of bottom part

s Faceting (guide rail width x tgα)

v Guide rail extension: max. 1000

► Guide extension and facet 59

► Guide rail fastenings 54

► Installation window 64

Connected systems

System width

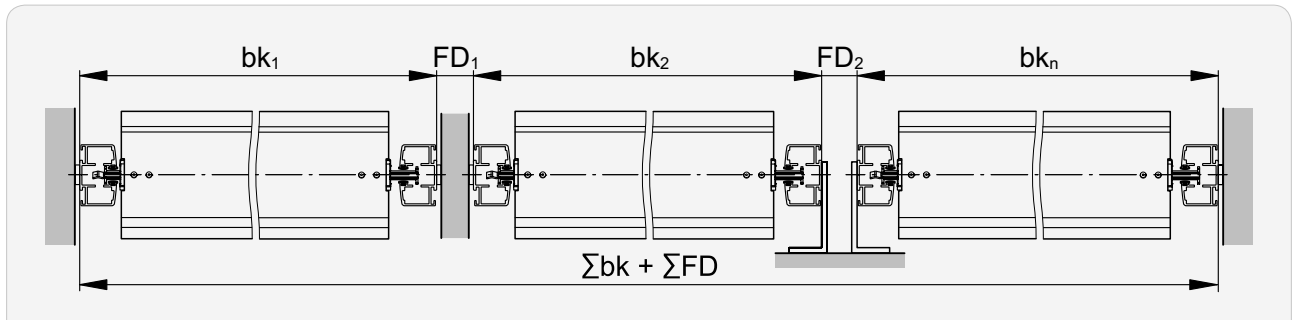

Distance between guides FD

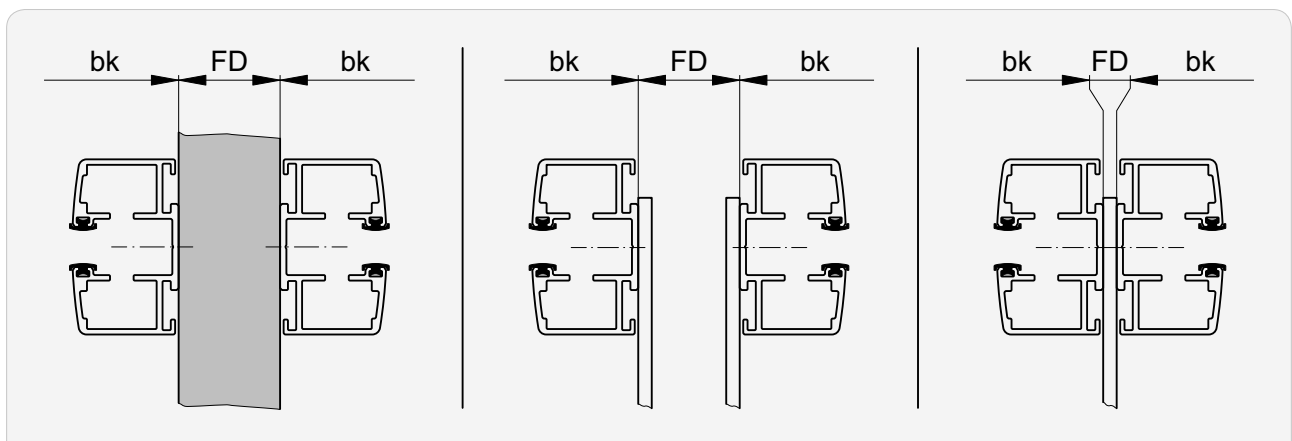

FD min.	FD max.
5	1000

►► Connected systems

Drawings for connected blinds

Gearbox

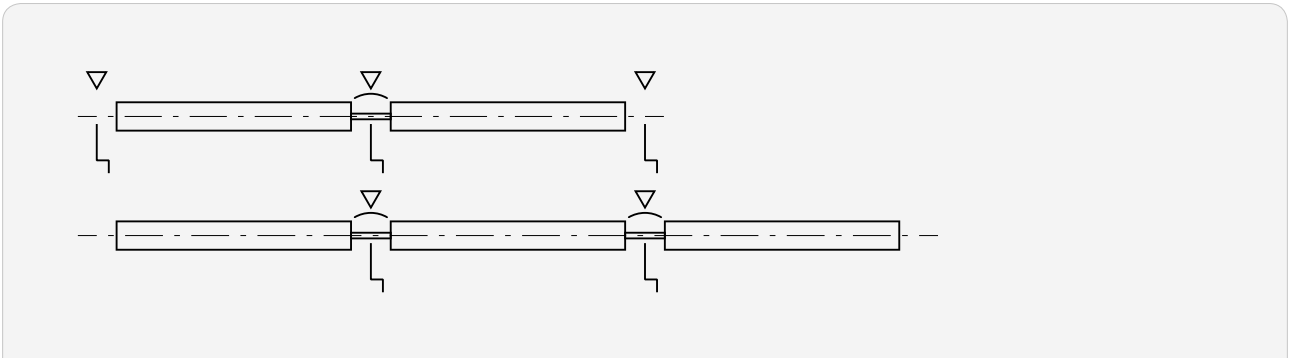

Motor

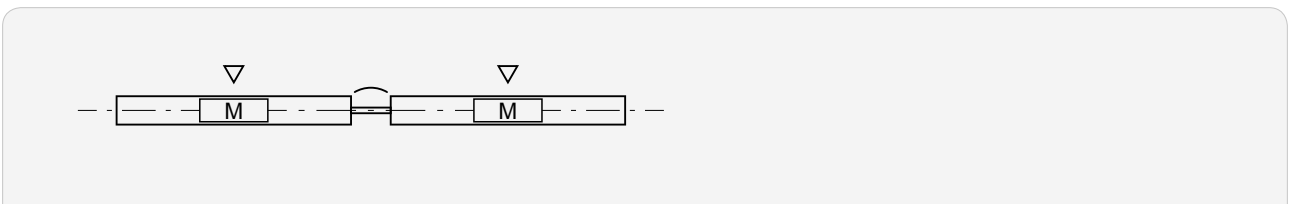

- ▼ Standard drive position
- ▽ Possible drive position

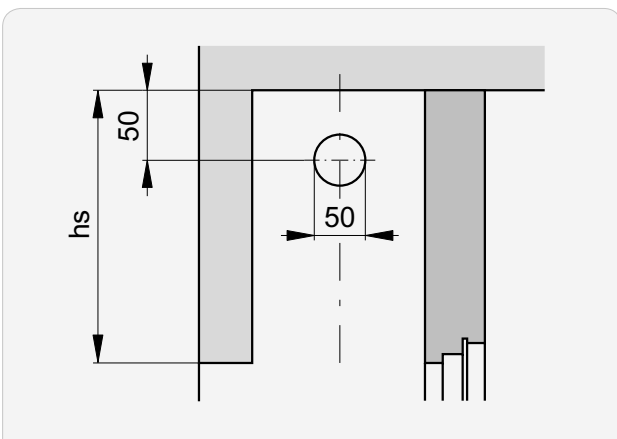

Technical data of motors

Performance characteristics

Type	Limit switch		M [Nm]	n [1/min.]	P [W]	I [A]
	Type	Number of				
Standard						
Elero Comfort						
ECM...	06.01	2	6	26	115	0.50
	09.01		9		156	0.68
	06.51	3	6		115	0.50
	09.51		9		156	0.68
ECB...	06.01	2	6	26	115	0.50
	09.01		9		156	0.68
	06.51	3	6		115	0.50
	09.51		9		156	0.68

I Current consumption

M Torque

n Rotational speed

P Power consumption



Lamisol® III

Limit dimensions	76
Built-in system	77
Built-in system with cover	78
Header dimensions Heights of package	80
Slat profiles	81
End rails	81
Beginning distance Slot spacing	82
Housing fastening	83
Number of box supports	85
Options	86
Guide rails	87
Sections Details	88
Sections for crank drive (MBMA)	90
Vertical connections Standard motor position	91
Guide rail installation (principle)	96
Guide rail fastenings (principle)	98
Guide extension and facet	106
Guide rail cut-outs in windowsill area	109
Guide rail end for suspended guide rails	111
Installation window	112
Fastening points	113
Connected systems	117
Technical data of motors	119



Limit dimensions

Single blind

Operation	Width min. (bk)	Width ¹ max. (bk)	Height min. (hl)	Height max. (hl)	Surface ² max. [m ²]
Crank drive	510* 530 ^{6,*}	4500	400	4300 4000 ⁵	10
Motor drive	590 630 ⁵				

Connected systems

Operation	Width ¹ max. (bk)		Blinds max.	Blinds per system	Surface ² max. [m ²]
Crank drive ³	510* 570 ^{6,*}			2... 4	10
Motor drive ⁴	590 670 ⁵	10 000	4	2 3... 4	16 24

¹ For buildings and high-rise structures, which are exposed to high winds, this maximum value should be decreased as required. Also see wind classes data sheet.

² If crank drive is in slat area: maximum surface area and crank position available on request.

³ A max. of 2 blinds may be connected on each side of the gearbox.

⁴ For 3 or 4 blinds, the motor should be positioned in the center.

⁵ Radio motor Geiger AIR

⁶ Lamisol® III Fix

* with MBMA– on request

Built-in system

Vertical section: Guide rail conventional

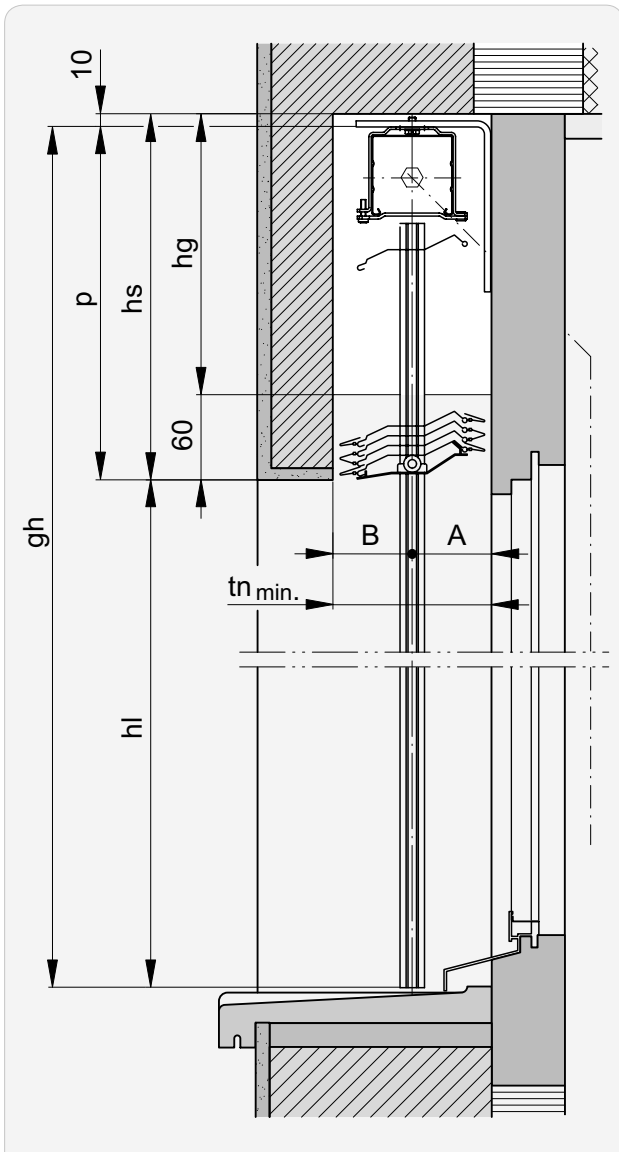

Vertical section: Guide rail Fix-L

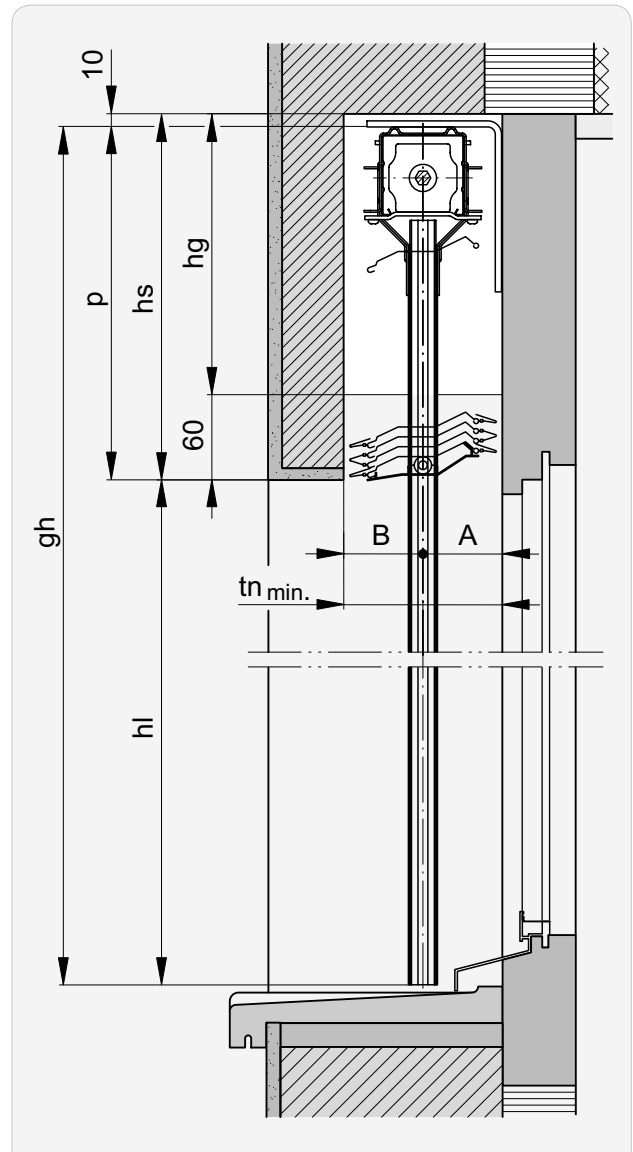

Horizontal section: Guide rail conventional

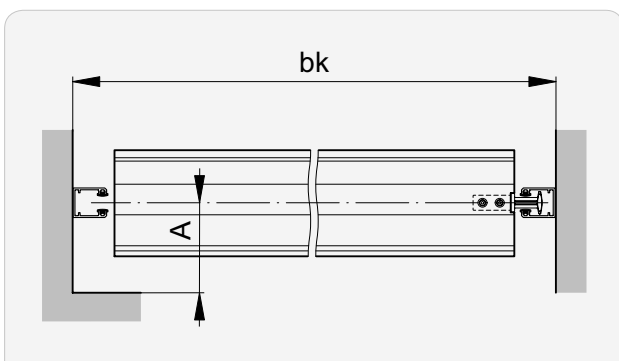

Horizontal section: Guide rail Fix-L

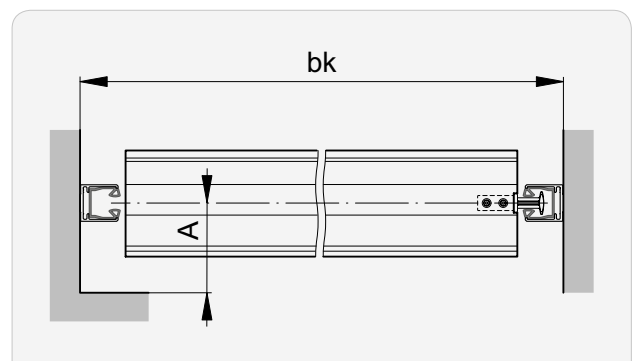

►► Built-in system

Vertical section: Guide rail Fix

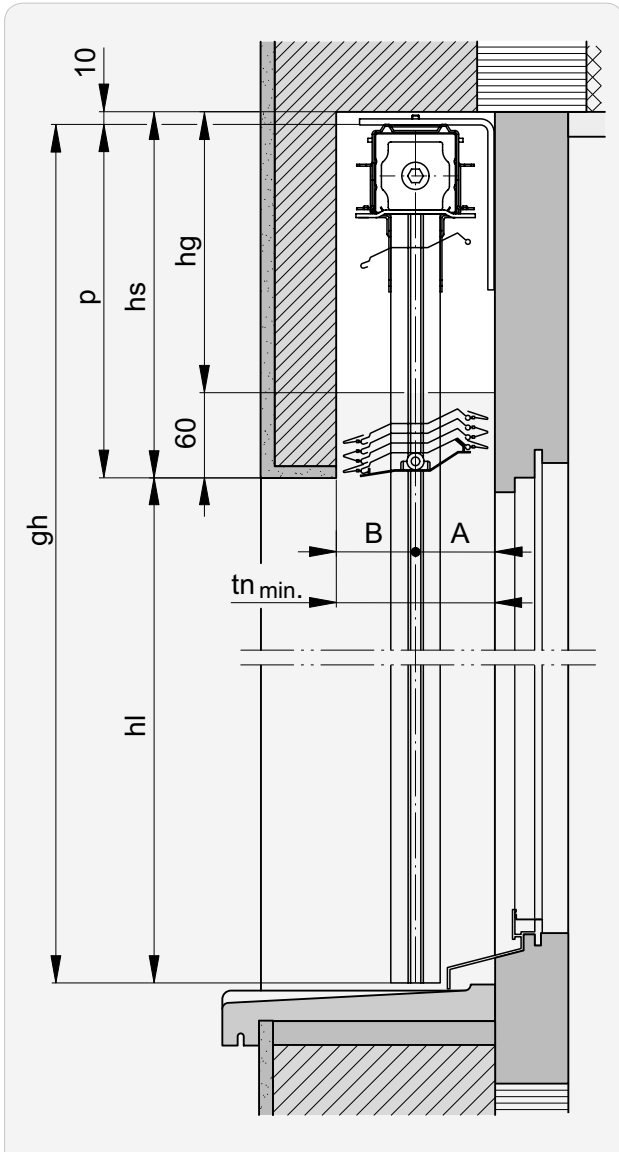

Built-in system with cover

Vertical section: Guide rail conventional

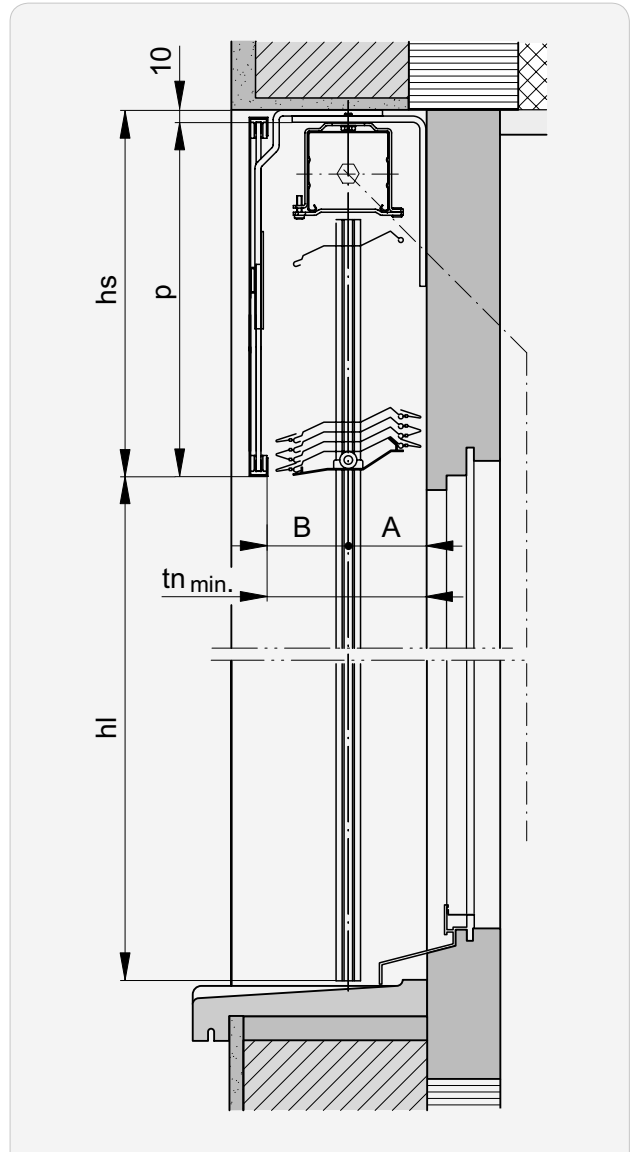

Horizontal section: Guide rail Fix

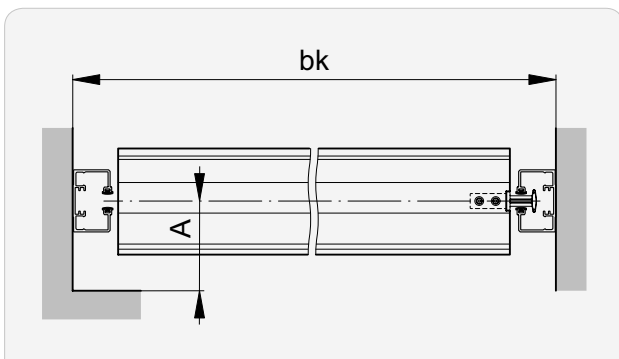

Horizontal section: Guide rail conventional

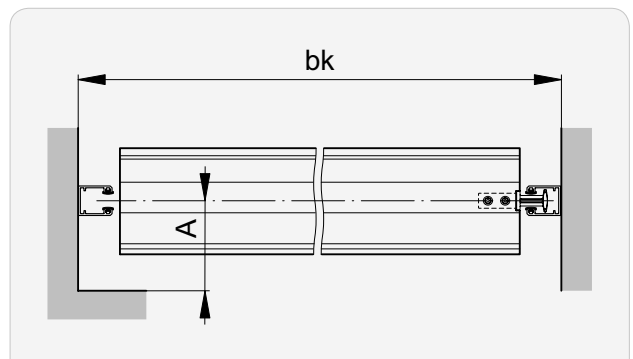

►► Built-in system with cover

Vertical section: Guide rail Fix-L

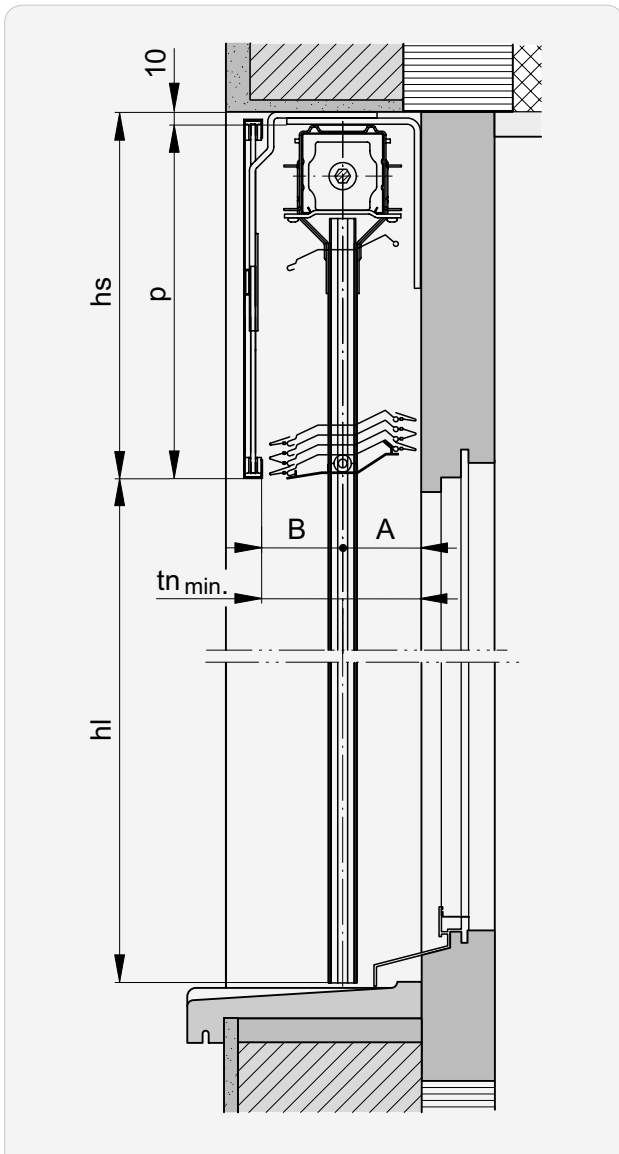

Vertical section: Guide rail Fix

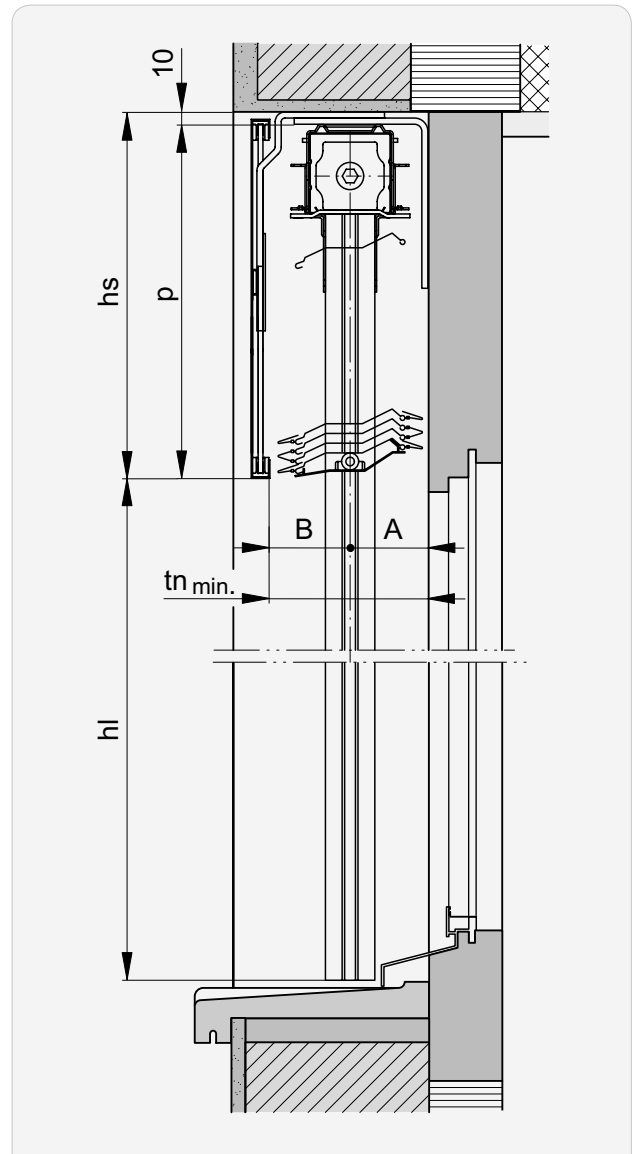

Horizontal section: Guide rail Fix-L

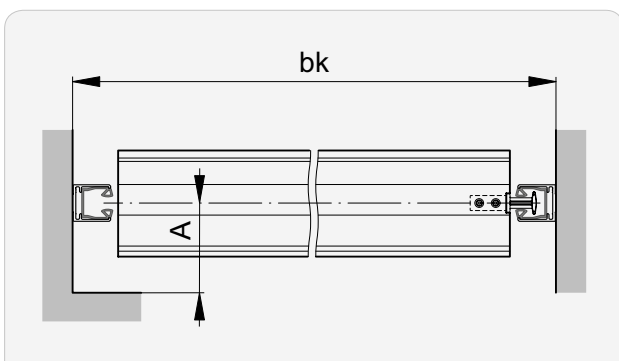

Horizontal section: Guide rail Fix

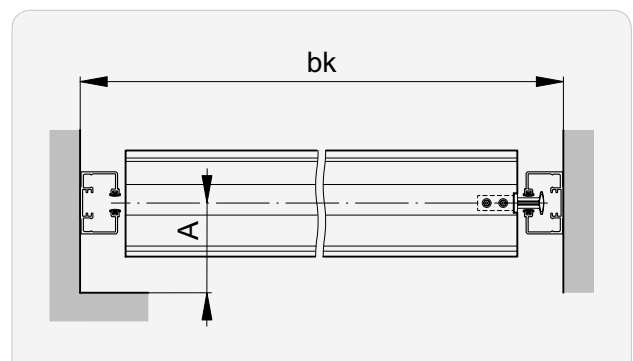

Header dimensions | Heights of package

Lamisol® III 70

hl →l	P min.	hs ¹	hl →l	P min.	hs ¹
1350	195	205	2850	295	305
1400	200	210	2900	300	310
1450	205	215	3000	305	315
1600	210	220	3050	310	320
1650	215	225	3100	315	325
1700	220	230	3200	320	330
1800	225	235	3300	325	335
1850	230	240	3350	330	340
1950	235	245	3450	335	345
2050	240	250	3500	340	350
2100	245	255	3550	345	355
2150	250	260	3650	350	360
2250	255	265	3750	355	365
2300	260	270	3800	360	370
2400	265	275	3850	365	375
2450	270	280	3950	370	380
2550	275	285	4000	375	385
2600	280	290	4050	380	390
2650	285	295	4200	385	395
2750	290	300	4250	390	400

tn min.	A	B
100*	50	50

Lamisol® III 90

hl →l	P min.	hs ¹	hl →l	P min.	hs ¹
1800	215	225	3150	285	295
1950	220	230	3200	290	300
2050	225	235	3300	295	305
2100	230	240	3350	300	310
2200	235	245	3450	305	315
2300	240	250	3500	310	320
2350	245	255	3650	315	325
2500	250	260	3750	320	330
2600	255	265	3800	325	335
2650	260	270	3900	330	340
2750	265	275	3950	335	345
2800	270	280	4050	340	350
2900	275	285	4200	345	355
3050	280	290	4250	350	360

tn min.	A	B
130*	65	65

¹ With gearbox in slat area: **hs + 20**.
Lamisol® III Reflect: **hs + 5**.

* + possible addition for protruding weatherboard or doorknobs.

i Header dimensions are approximate values which may exhibit **negative or positive deviations** depending on the technical circumstances. **A dimensional tolerance of ±5 mm** is observed for the header height.

Slat profiles

Lamisol® III 70

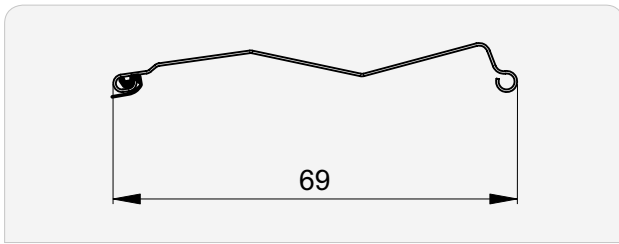

Lamisol® III 90

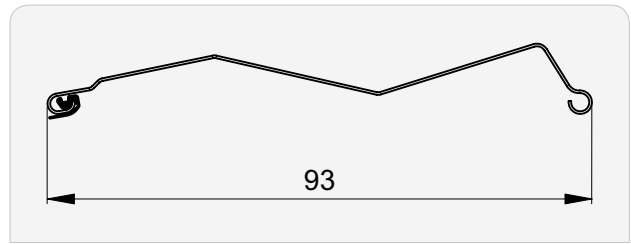

End rails

Lamisol® III 70

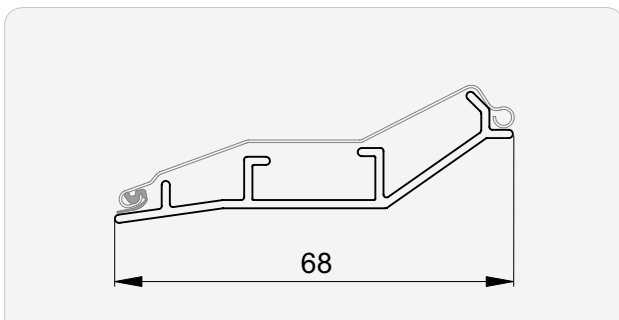

Lamisol® III 90

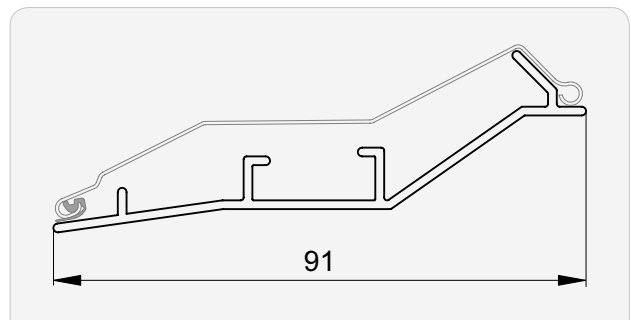

Beginning distance | Slot spacing

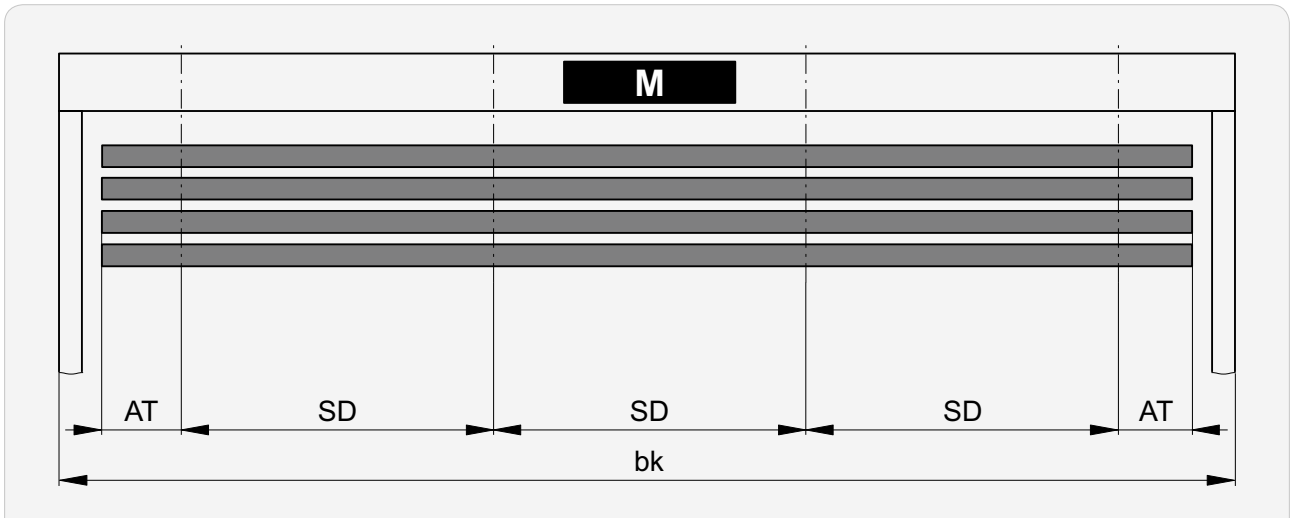

bk	AT min.		SD min.	SD max.
≤ 610	Conventional	50	350*	1000*
	Fix	60		
	Fix connected	80		
611 ... 1250		100		
> 1250		200		
Special		250		

* Standard slot spacing machine fabrication

Deviations from the standard are possible when:

Deviation	Correction
MBMA+ < 40	AT
Support loading too high	AS
Slot spacing < 350	AT + AS
With motor	AT + AS

AT Beginning distance
Distance from beginning of slat to centre of bearing

SD Slot spacing
Distance from centre of bearing (slot) to centre of bearing (slot)

Housing fastening

At top

NO

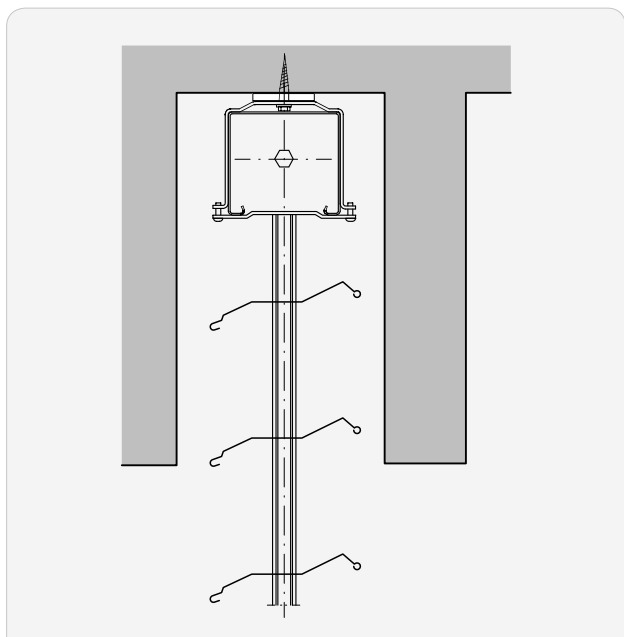

Box support

KT

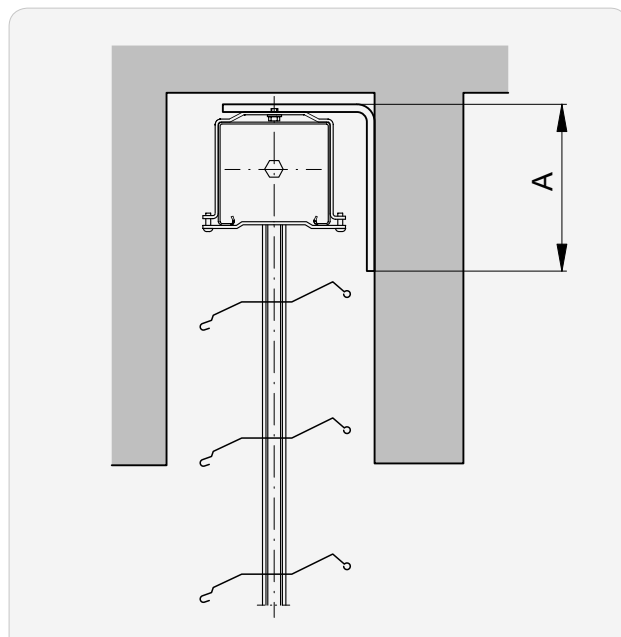

Box support for type KT, for small headers*

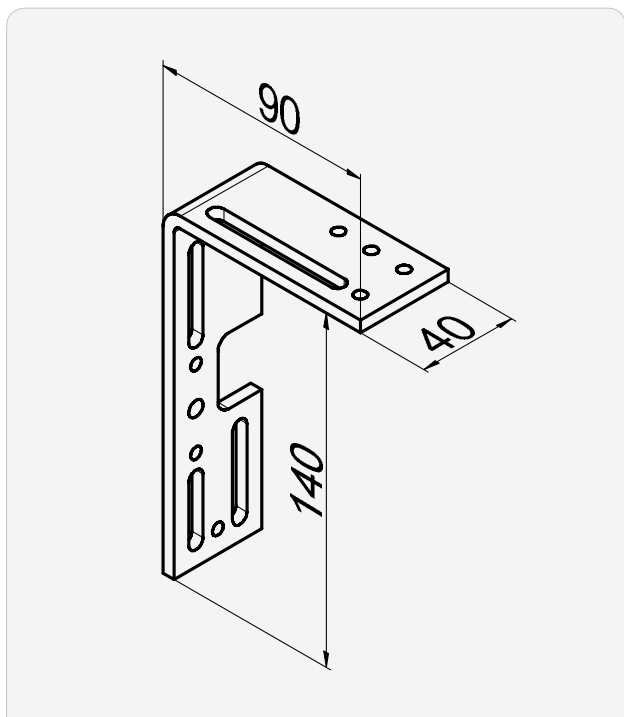

A
140

Box support for type KT

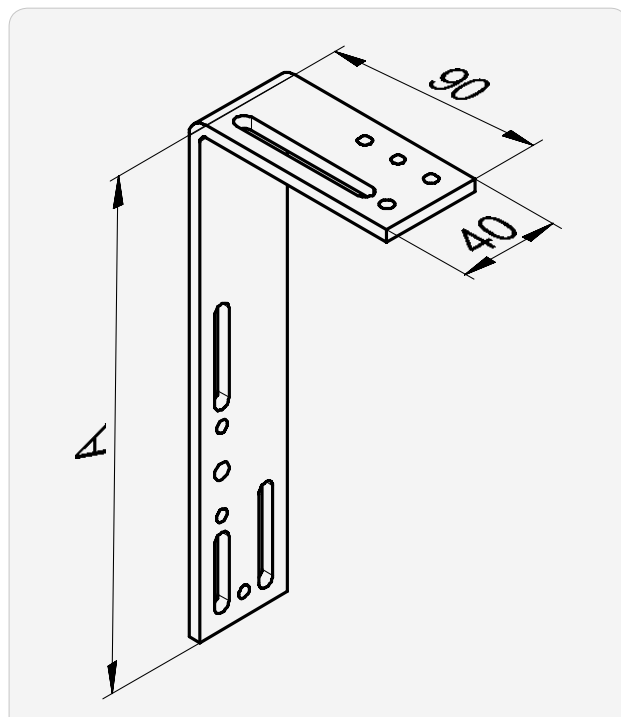

A
200
260

* Header 100

►► Housing fastening

Double box support

DR

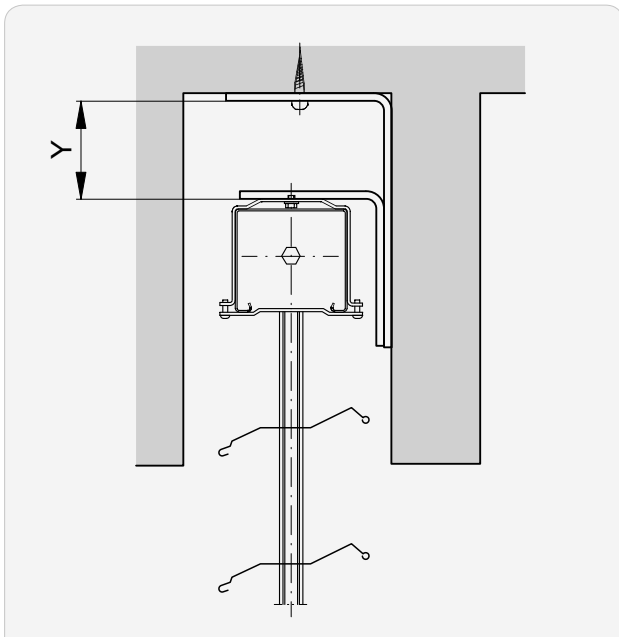

Gallery clip

GB

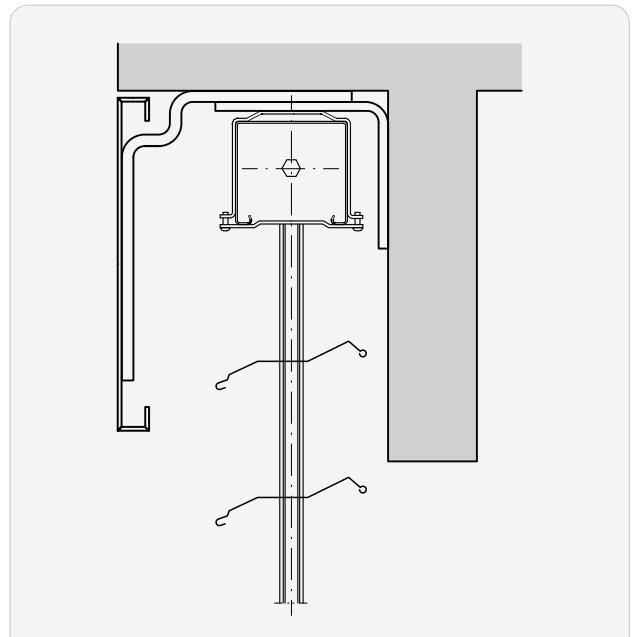

Double box support for type DR

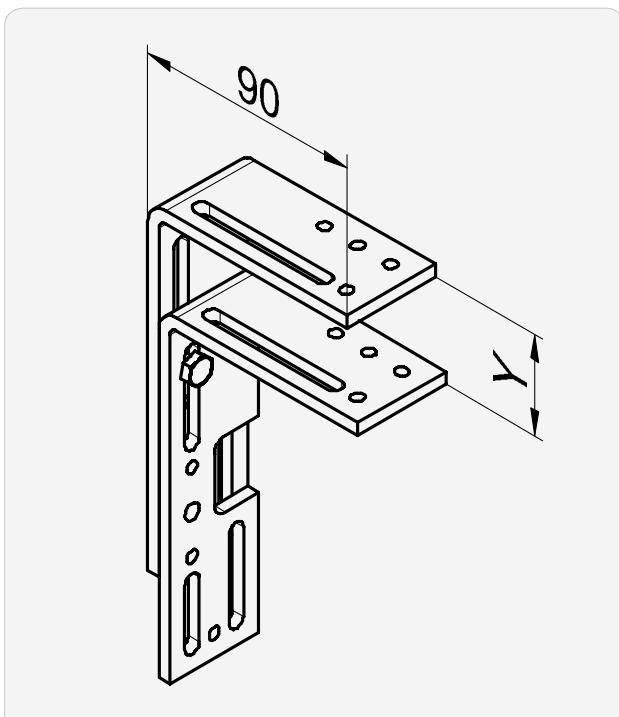

Gallery clip for type GB

i See additional documentation:
Short manual "Covers"



[↓ Covers](#)



Y

10... 75

75... 135

135... 200

Number of box supports

Conventional guides

bk	Quantity
≤ 2000	2
2001 ... 3000	3
3001 ... 4000	4
> 4000	5

Fix guides | Additional fastenings

bk	Quantity
≤ 2500	0
2501 ... 3500	1
> 3500	2

Options

Lamisol® III Reflect

i For glare protection at bottom and use of daylight at top.

Lamisol® III 70

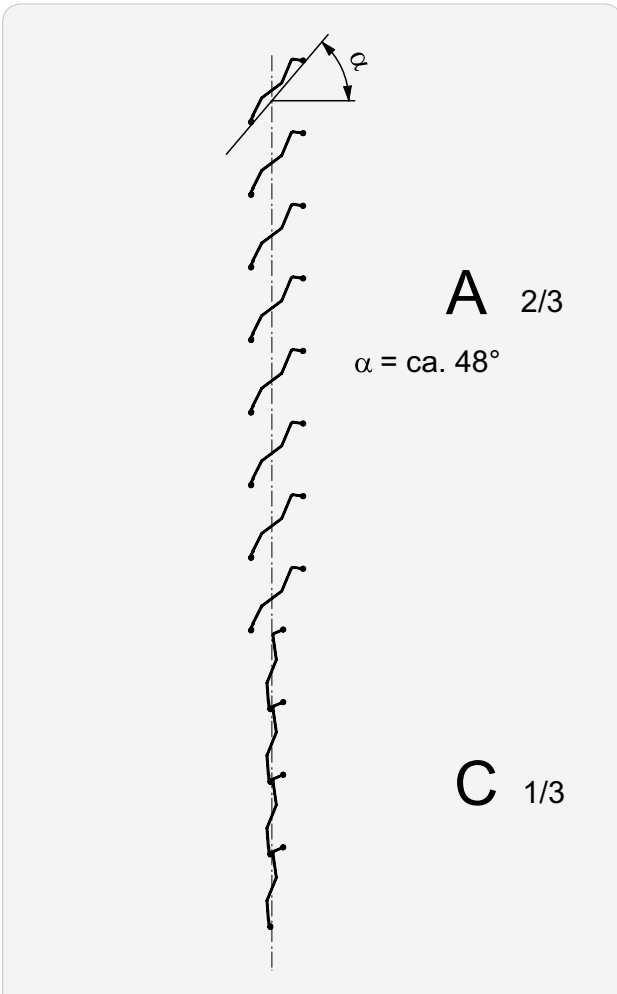

Lamisol® III 90

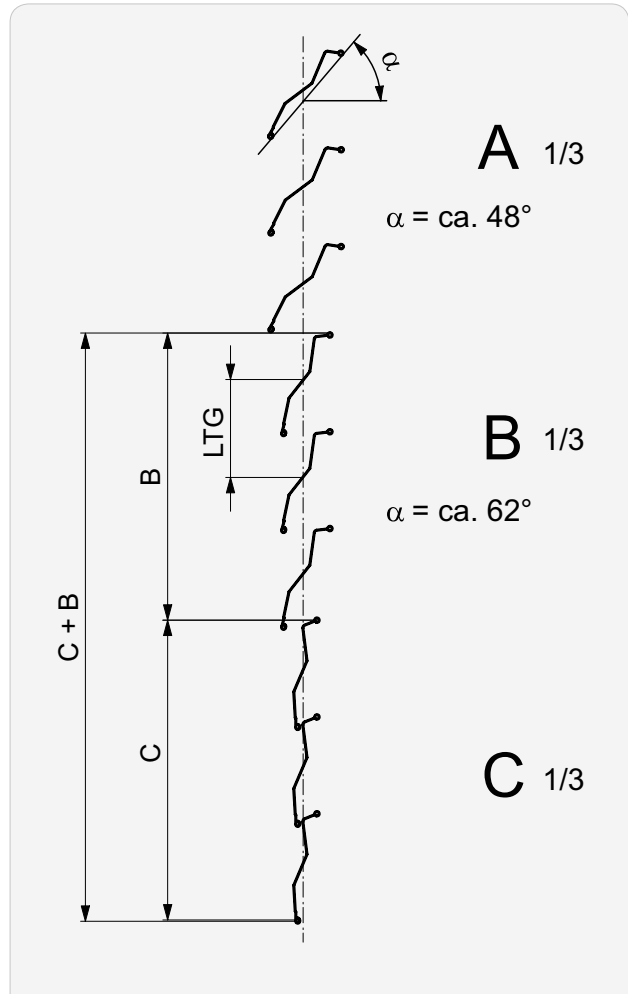

i For technical reasons, the Reflect zone (**C + B**) must be two slat spacing units larger than the Reflect zone **C**.

- A** Use of daylight
- B** Ability to see outside
- C** Glare protection
- LTG** Slat spacing

Guide rails

Type E | Single guide

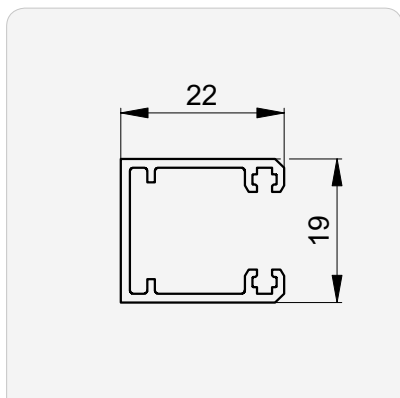

Type L | Fix guide

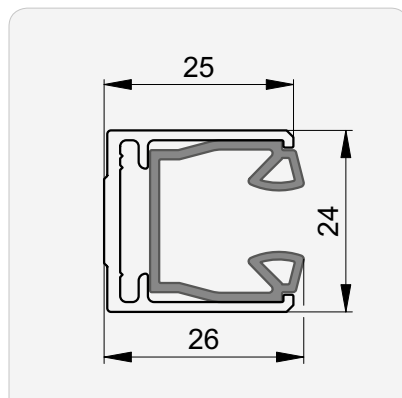

Type F | Fix guide

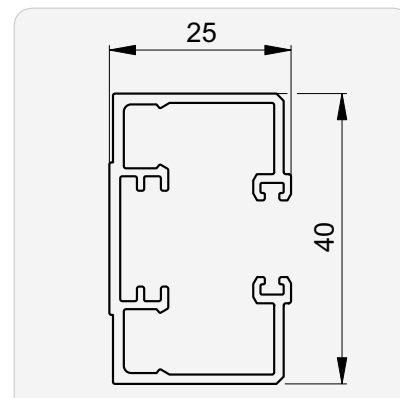

Type D | Double guide

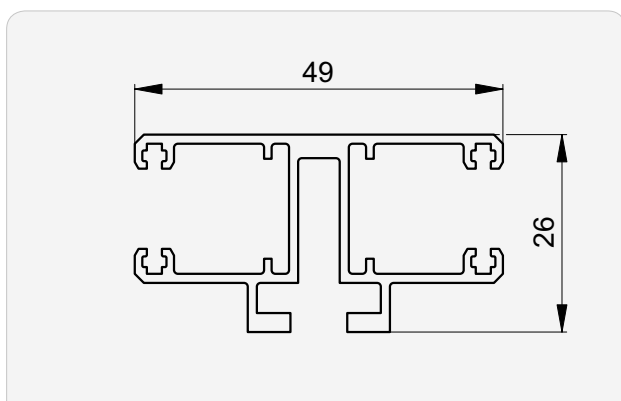

Special guide fastening required

Type C | Single guide

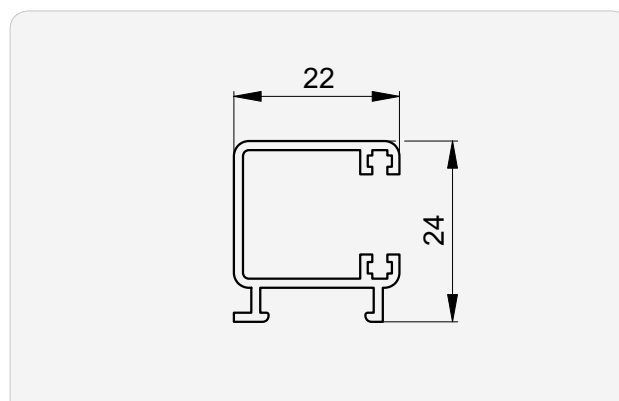

Type R | Curved double guide

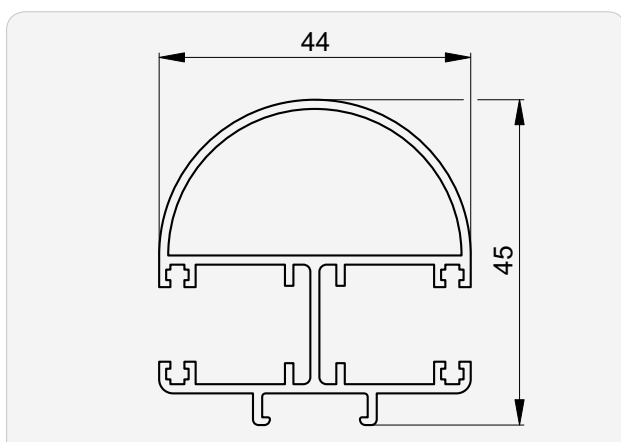

Type T | Double guide

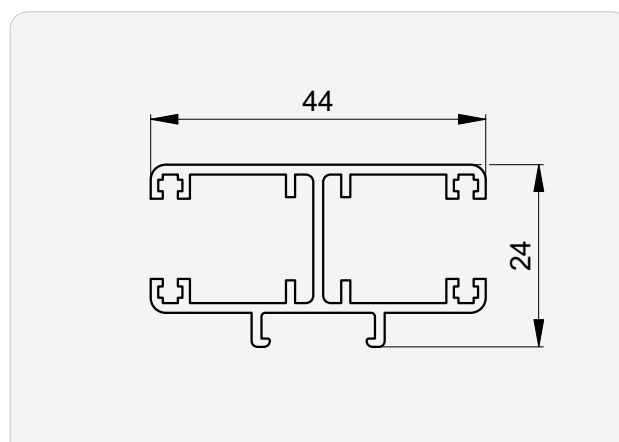

➤ Distance between guides FD	117
➤ Fastening points	113
➤ Guide extension and facet.....	106
➤ Guide rail fastenings	98

➤ Guide rail cut-outs in windowsill area.....	109
➤ Installation window.....	112
➤ Integrated guides	97

Sections | Details

Horizontal section: Guide rail conventional

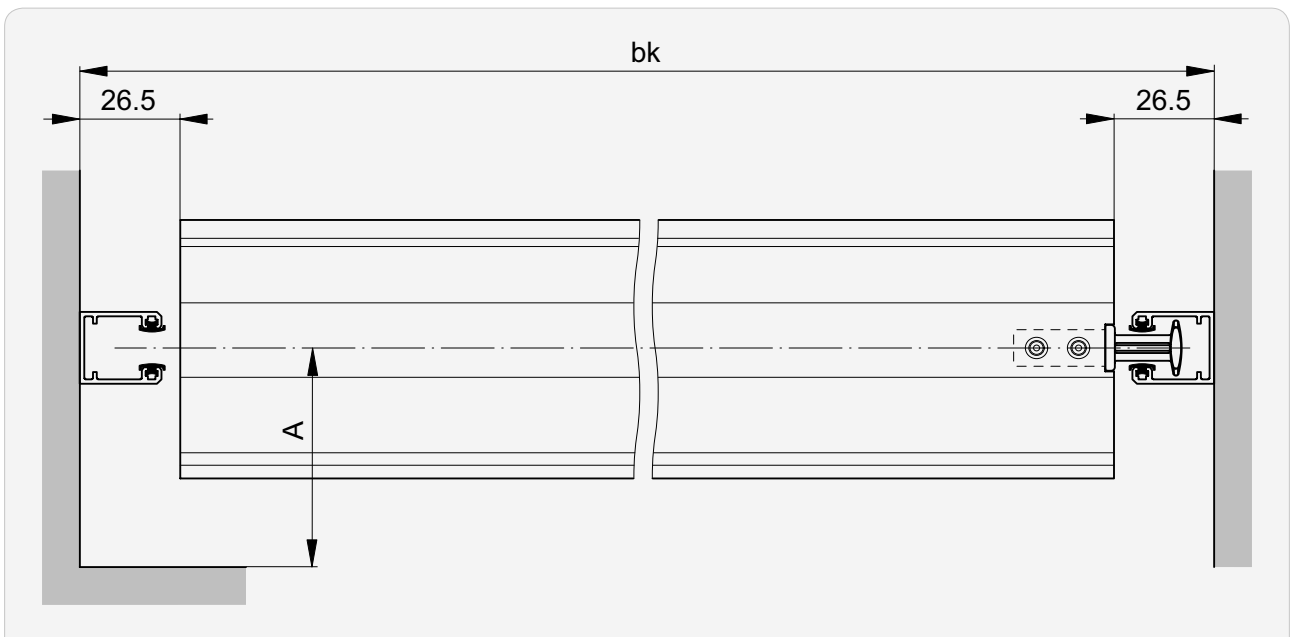

Horizontal section: Guide rail Fix-L

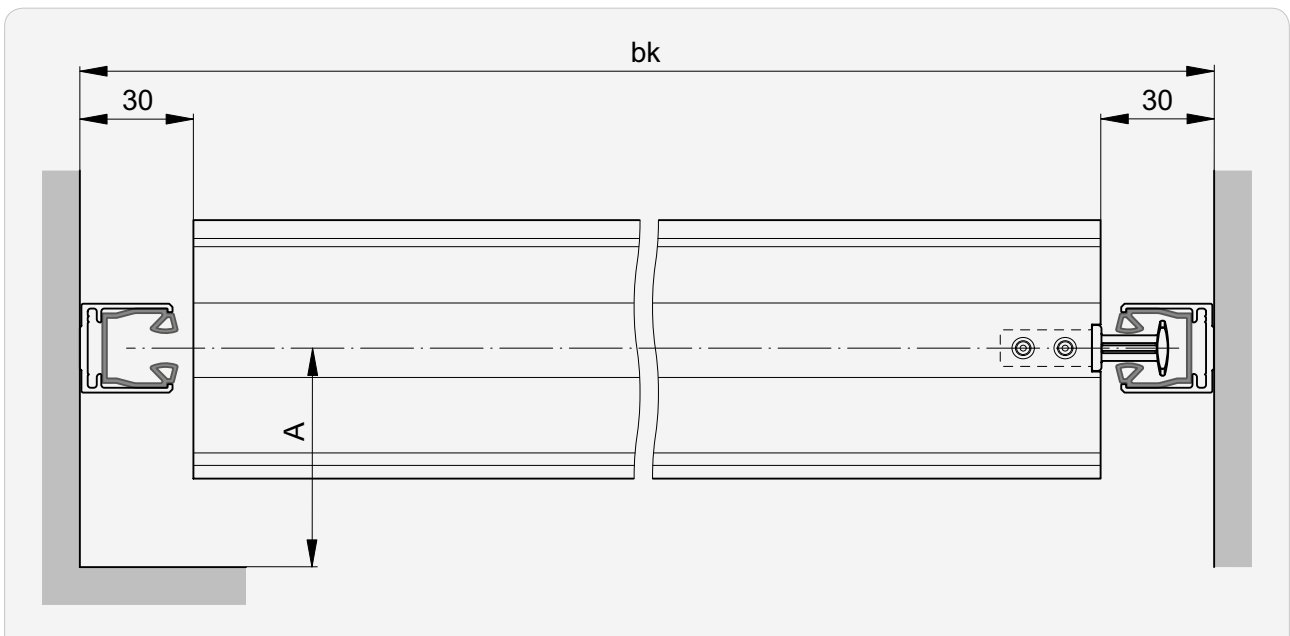

➡ Value for A 80

►► Sections | Details

Horizontal section: Guide rail Fix

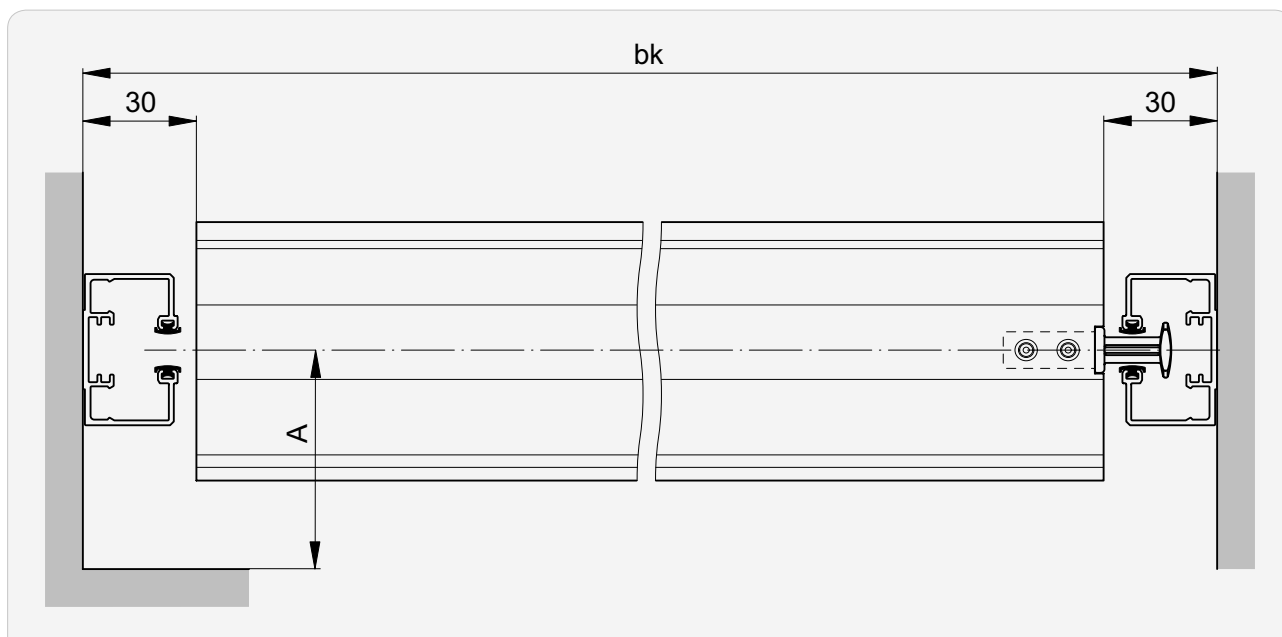

Detail at bottom

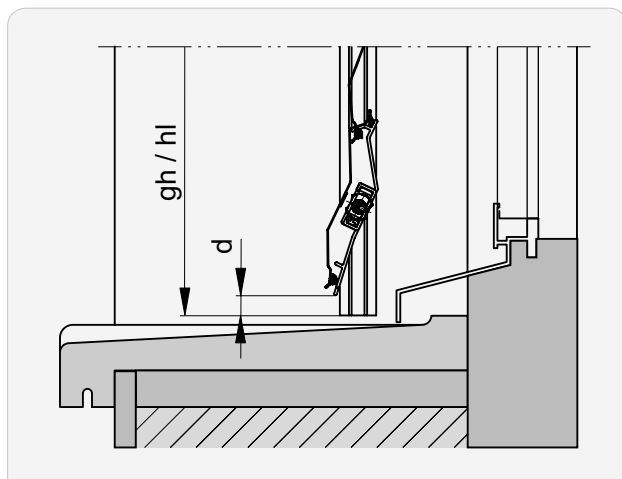

d (d-dimension)

5 +5/-3 (Lamisol® III Reflect: 15 +5/-3)

i **d-dimension** may vary with different blind dimensions.

➡ Value for **A** 80

Sections for crank drive (MBMA)

outside bk

Conventional

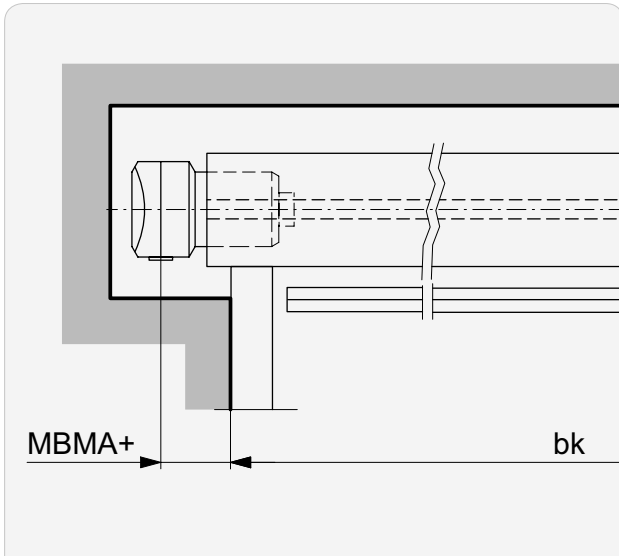

Self-supporting (Fix)

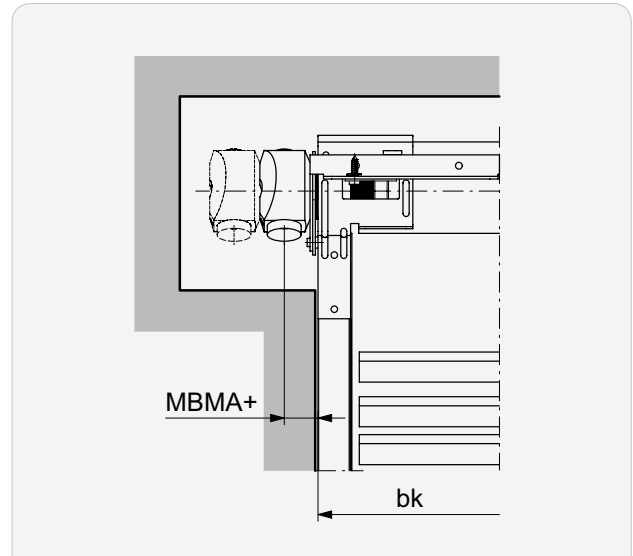

within bk

Conventional

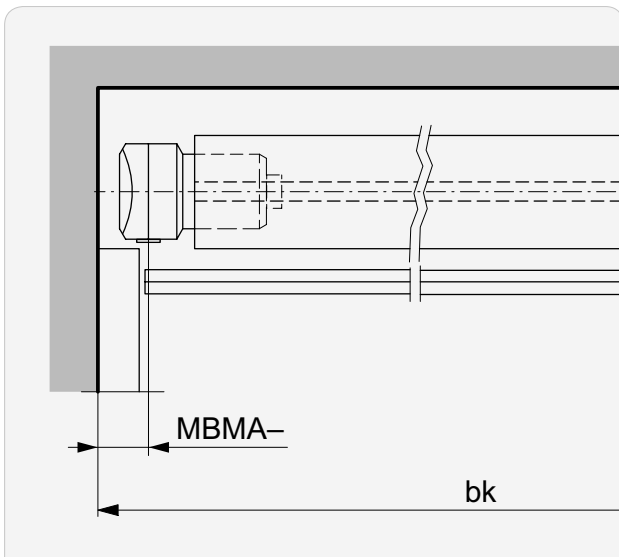

Self-supporting (Fix)

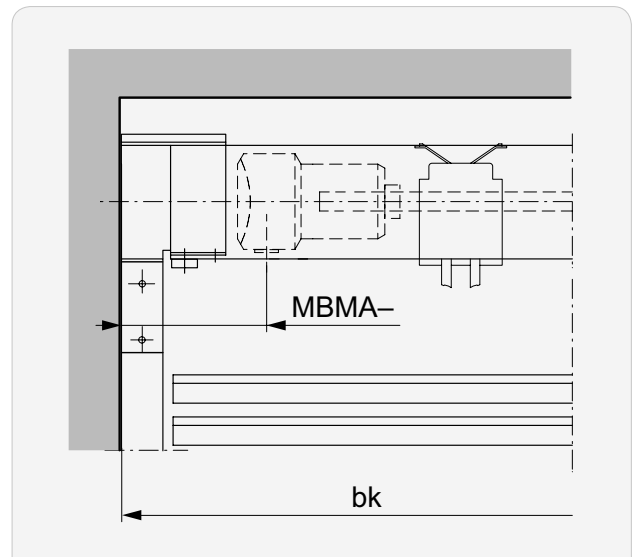

Version	MBMA+	MBMA-
Conventional	0 ... 500	0 ... (bk/2)*
Self-supporting (Fix)	26 ... 125 (10 ... 25) ¹	90 ... (bk/2)

¹ for reverse mounted gearbox

* ≤30: Gearbox niche required

Vertical connections | Standard motor position

Number of bearings

Lamisol® III 70

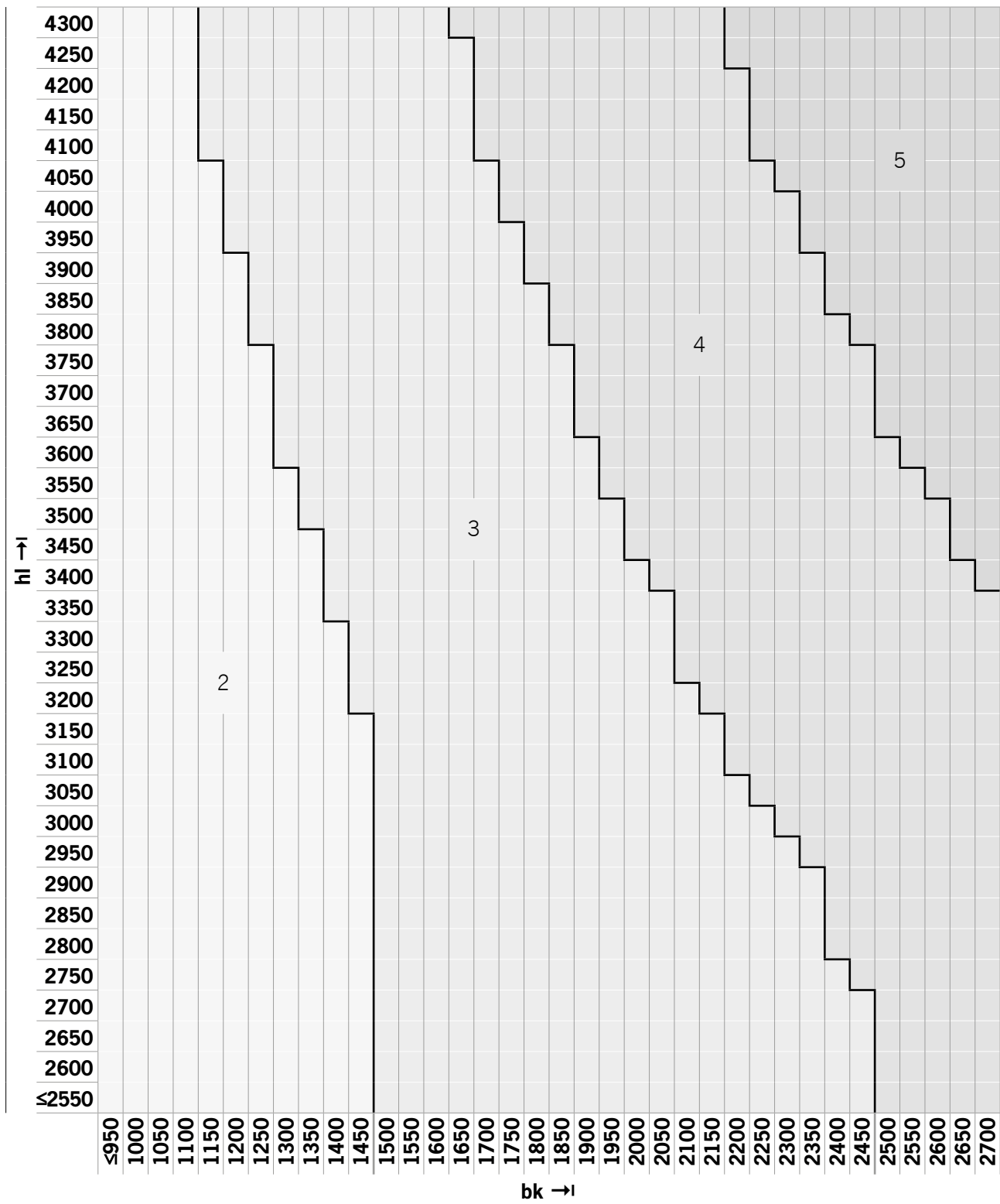

►► Vertical connections | Standard motor position

Number of bearings

Lamisol® III 70

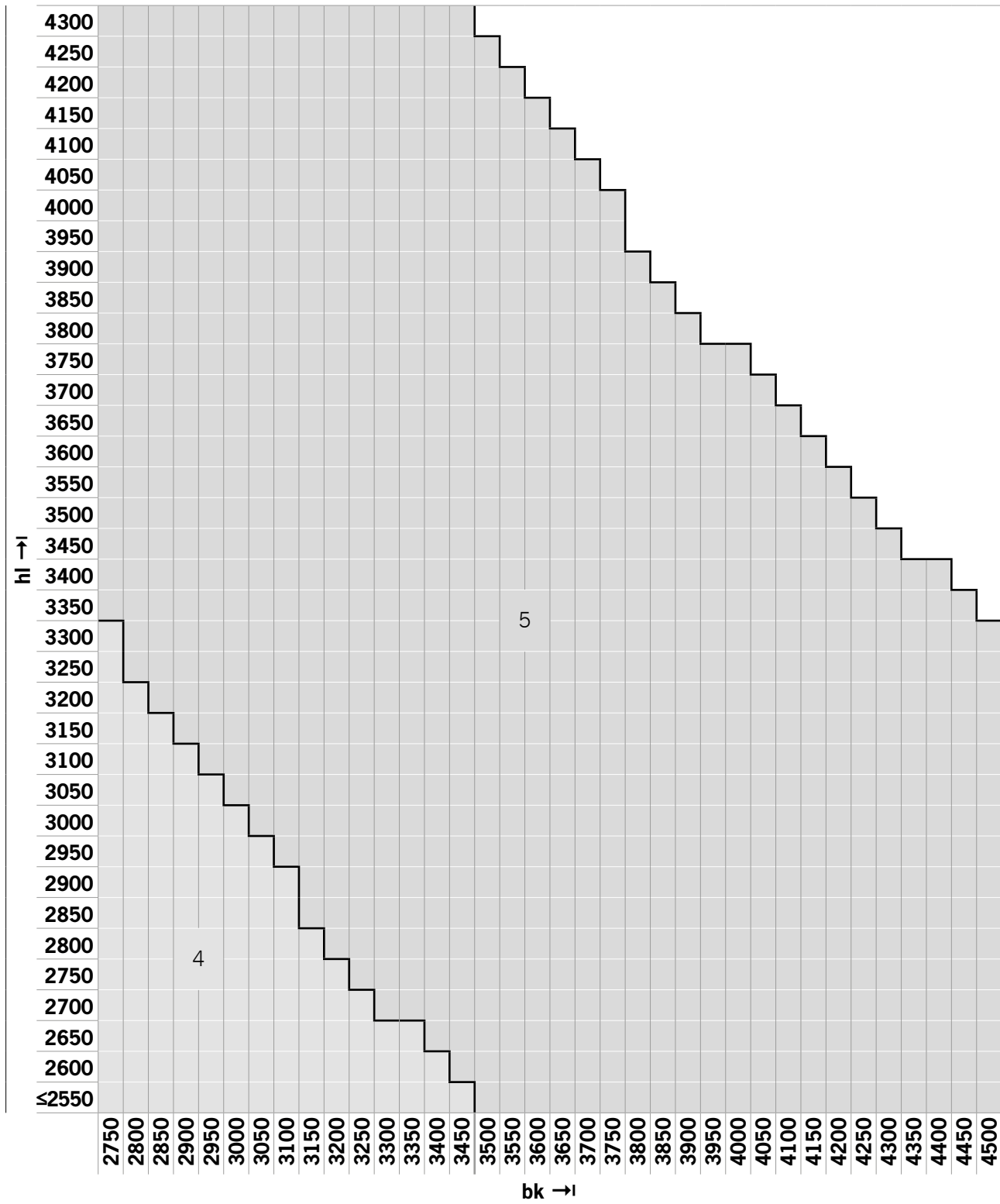

►► Vertical connections | Standard motor position

Number of bearings

Lamisol® III 90

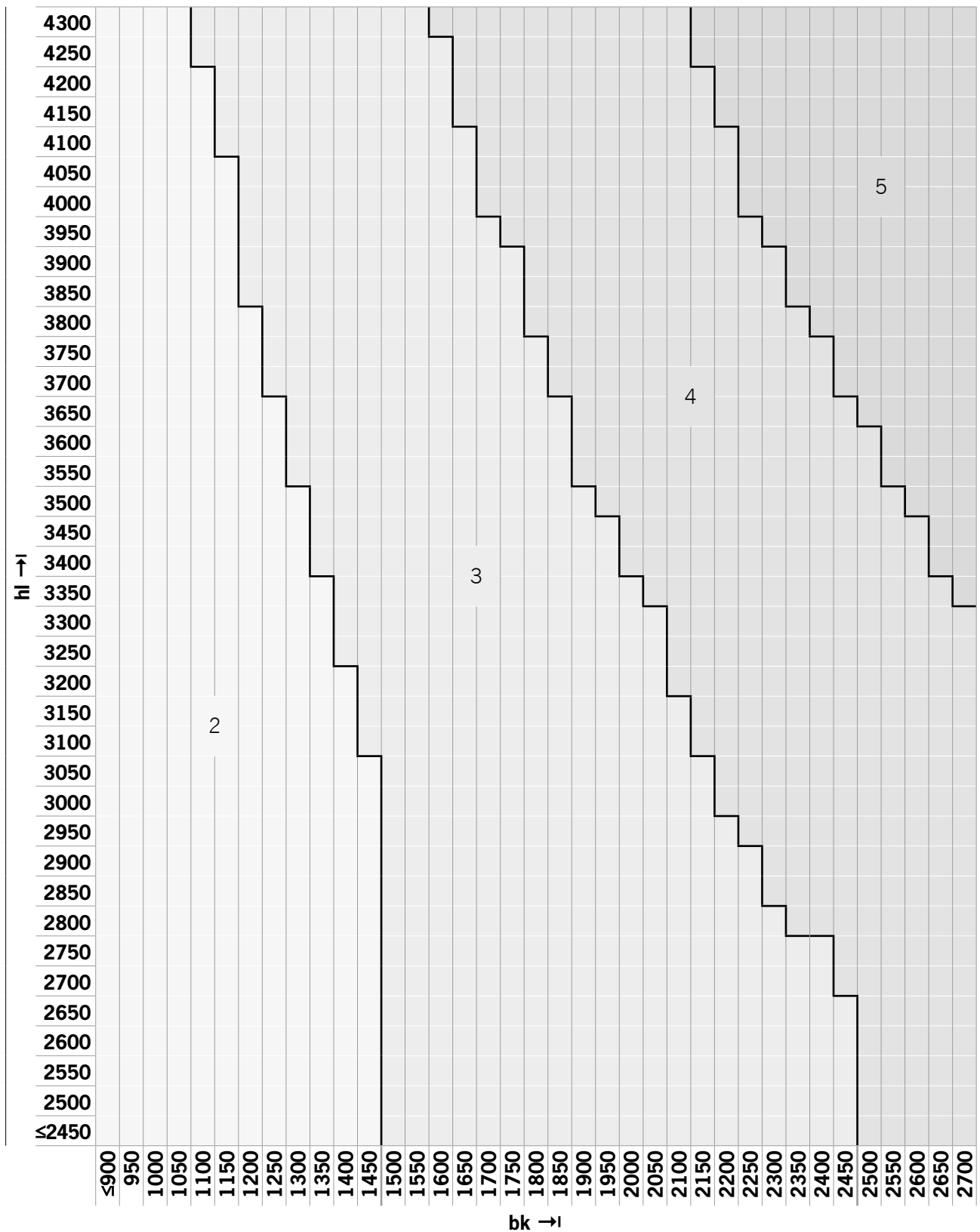

►► Vertical connections | Standard motor position

Number of bearings

Lamisol® III 90

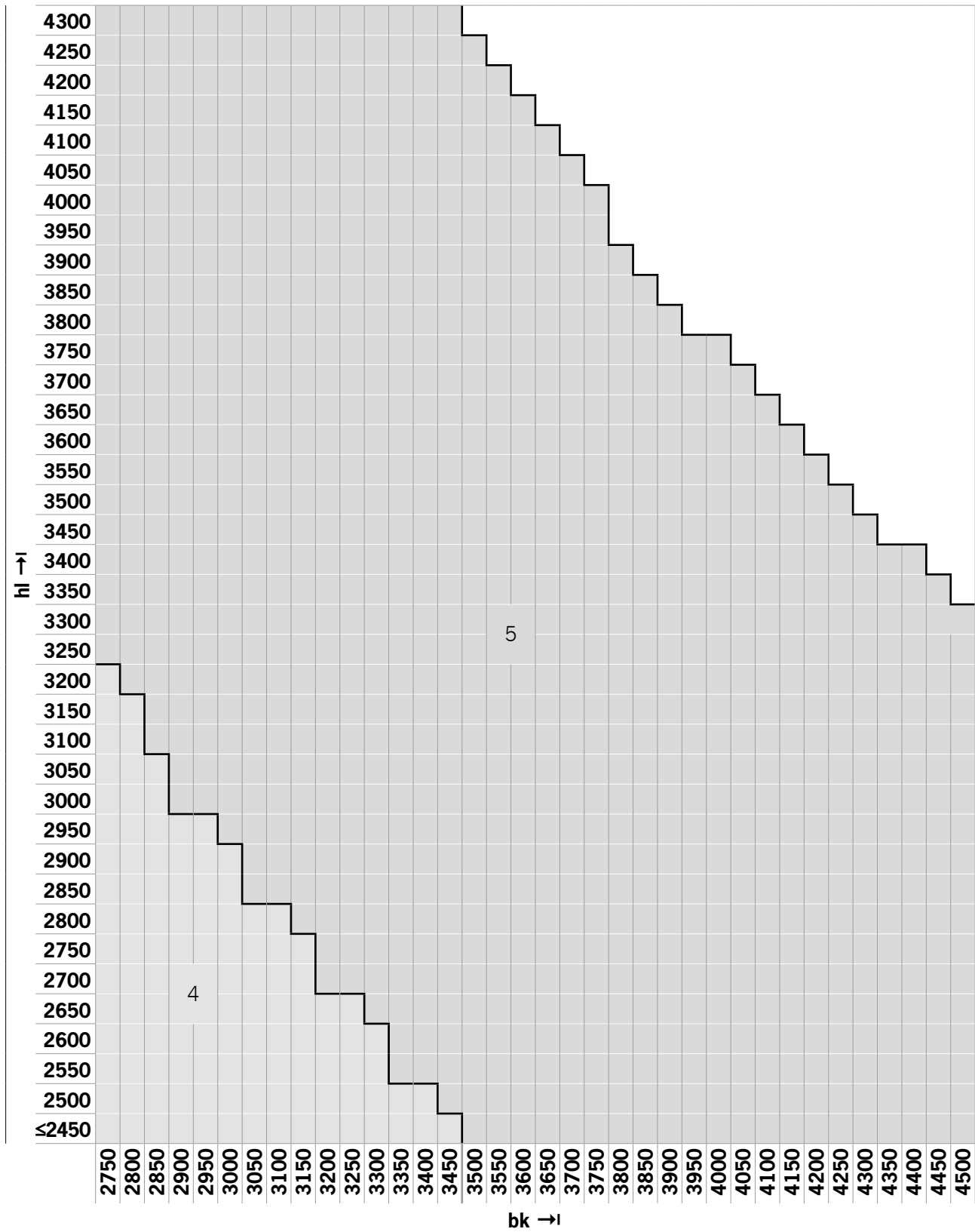

►► Vertical connections | Standard motor position

Standard motor position

Number of bearings

Standard motor position

2



3

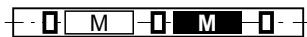

4



5

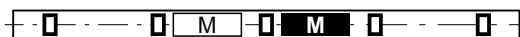

Bearing

Standard motor position

Possible motor position (on request)

Guide rail installation (principle)

Guides attached (to soffit) | Type A

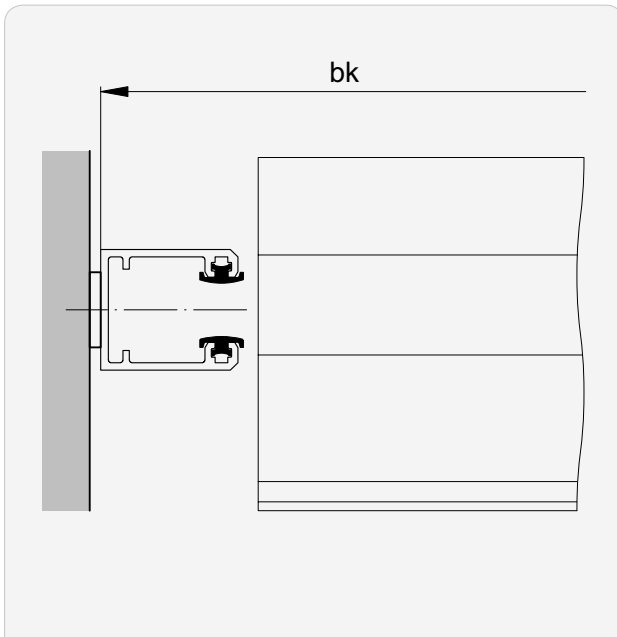

Guides suspended

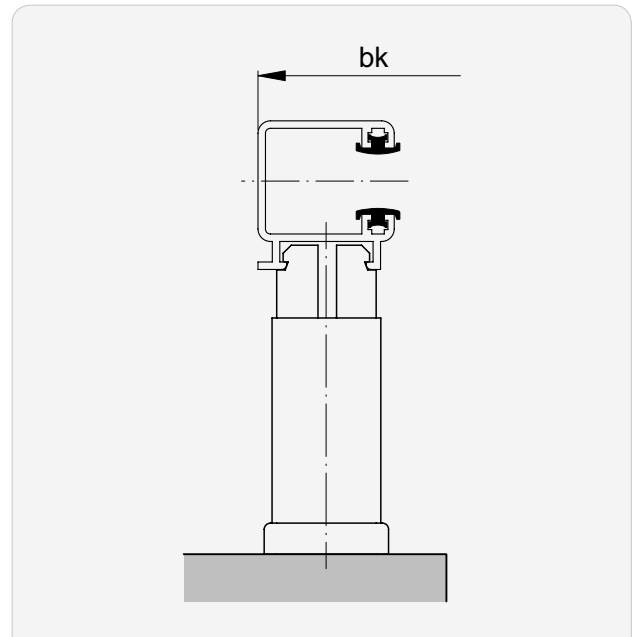

i Observe possible guide rail spacer for **bk**.
Standard: 2 mm

►► Guide rail installation (principle)

Guides recessed

i *Type F | Without guide cut-out:
Only possible if curtain can be retracted from below.

Type E | F* | L

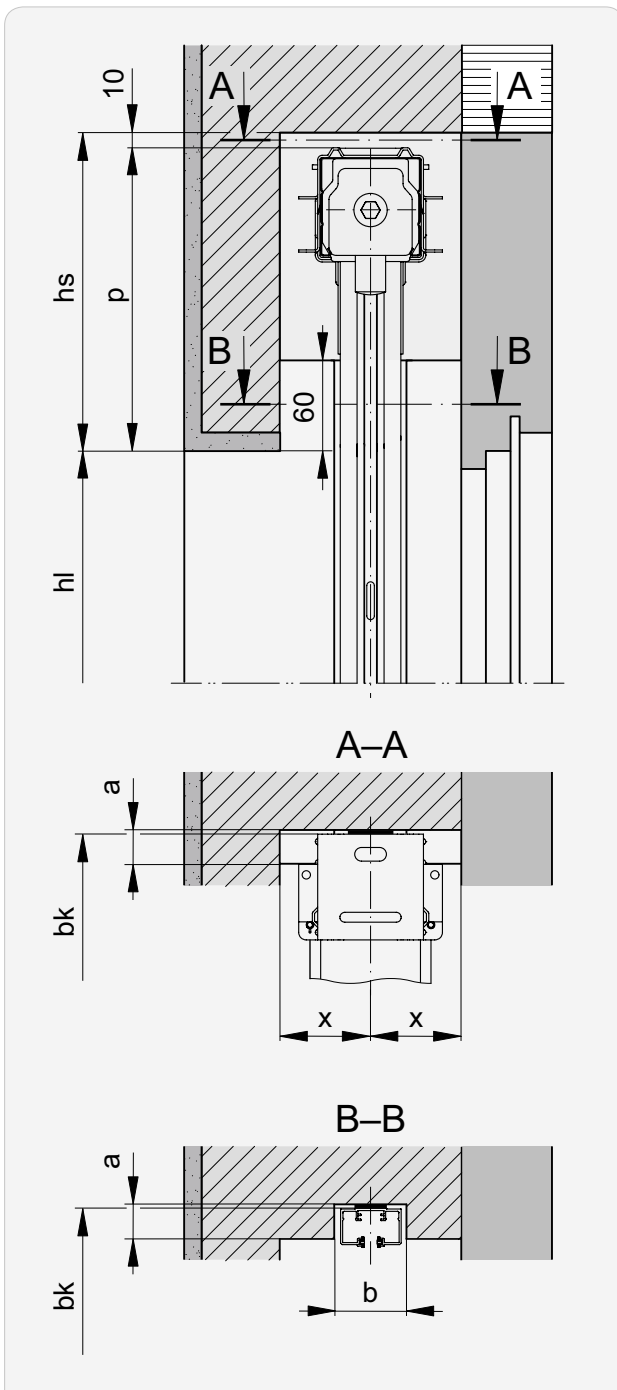

Type E

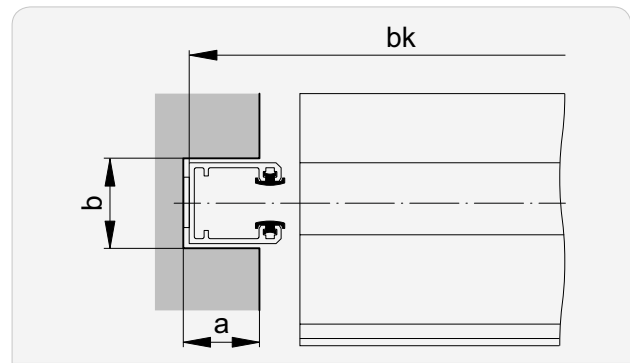

Type F*

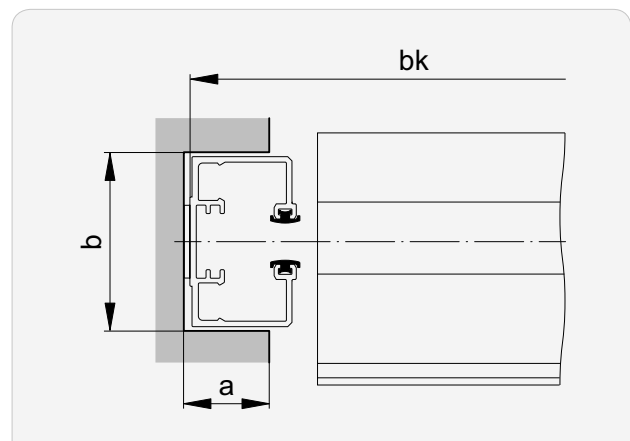

Type L

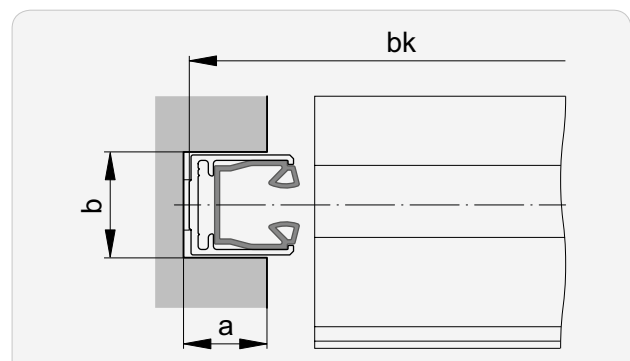

Product Version	x min.
Lamisol® III 70 Fix	50
Lamisol® III 90 Fix	65

Type	a	b
E	≤ 18	≥ 21
F*	≤ 20	≥ 42
L	≤ 24	≥ 25

Guide rail fastenings (principle)

Overview

														Type		
A	B	Bd	C	Cd	E	F	G	H	Kv	M	T	Tv	V	Wv		
●	●	●	●	●	●	●	–	○ ¹	○ ²	○ ³	●	●	●	●		

- applicable without restrictions
- applicable with restrictions:
 - ¹ only with guide **type D**
 - ² only with guide **type C | T | R**
 - ³ only with guide **type E**

A Soffit installation

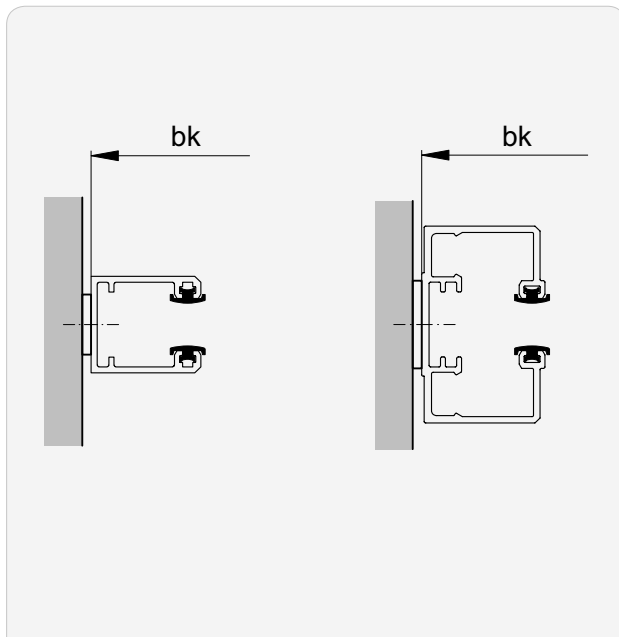

i Observe possible guide rail spacer for **bk**.
Standard: 2 mm

►► Guide rail fastenings (principle)

B Installation with fastening bracket

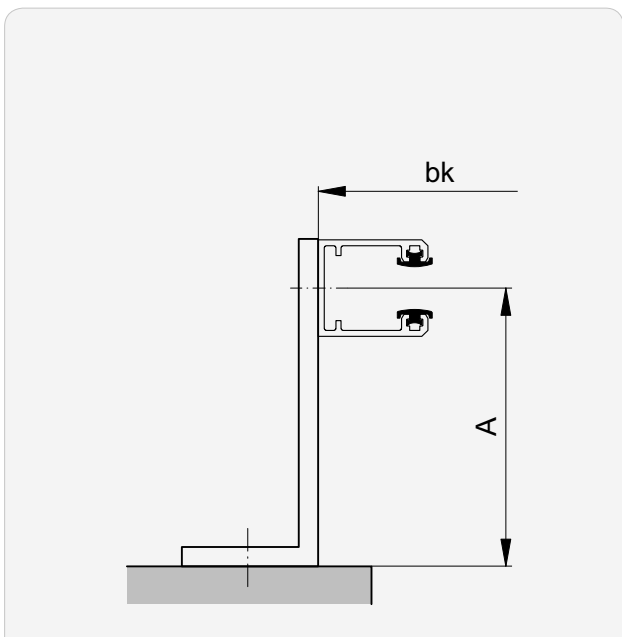

Bracket outwards

C Installation with fastening bracket

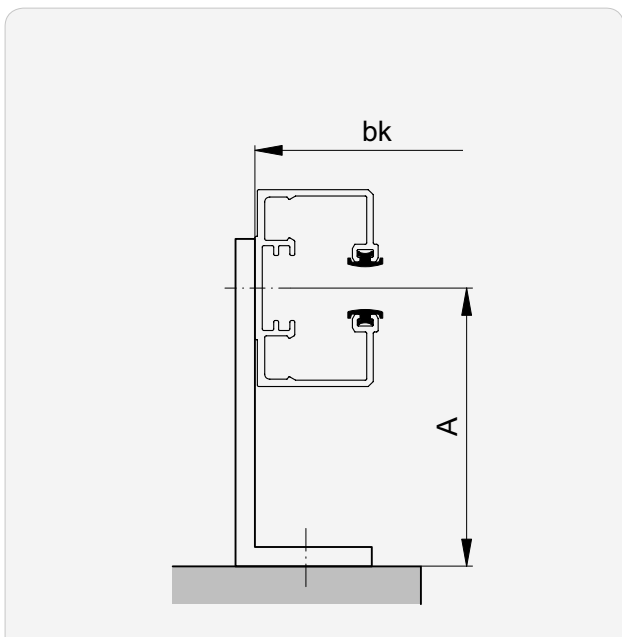

Bracket inwards

Fastening bracket for types B and C

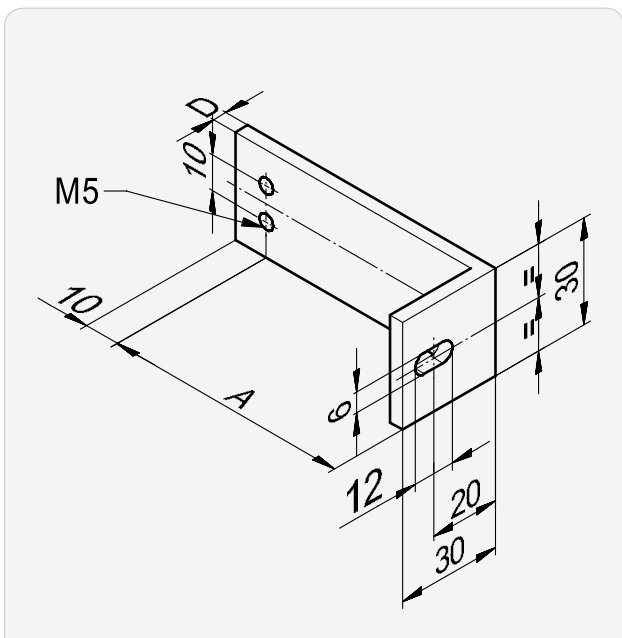

A*	D
20... 115	4

Fastening bracket 70mm for types B and C

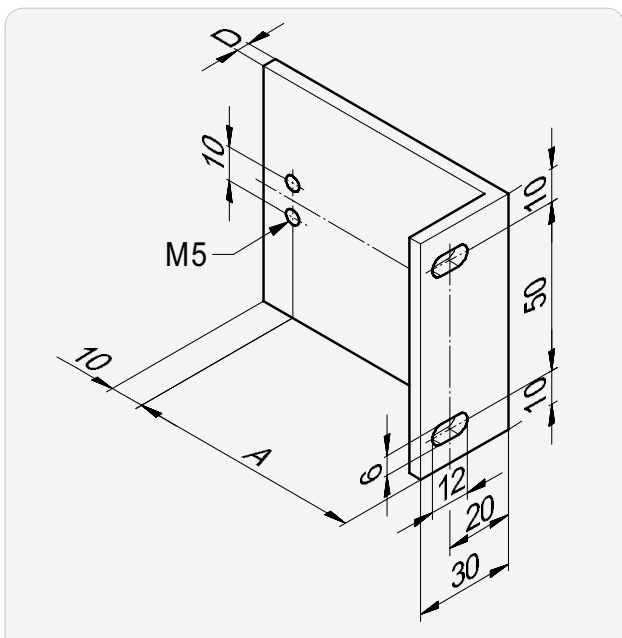

A*	D
20... 115	4
120... 215	5

i For suspended guide rails always with **brackets 70mm**.

i If the **projection is ≥120**, all products are fastened with a **70mm bracket**.

* in 5 mm steps

►► Guide rail fastenings (principle)

Bd Installation with continuous fastening bracket

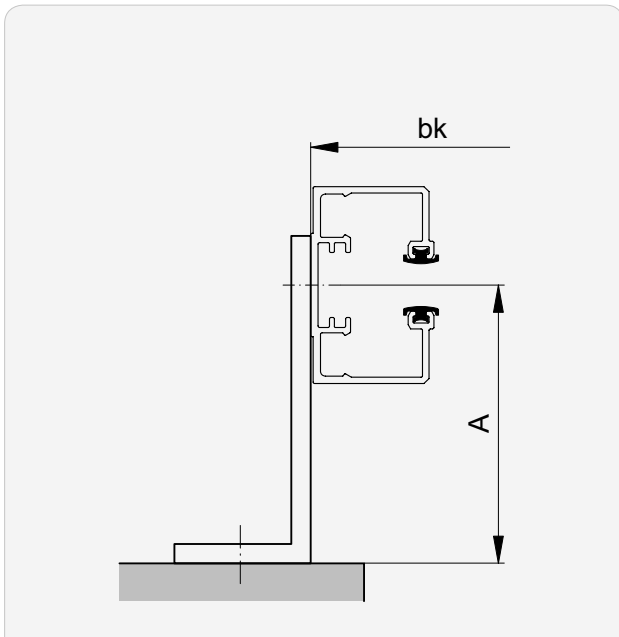

Bracket outwards

Cd Installation with continuous fastening bracket

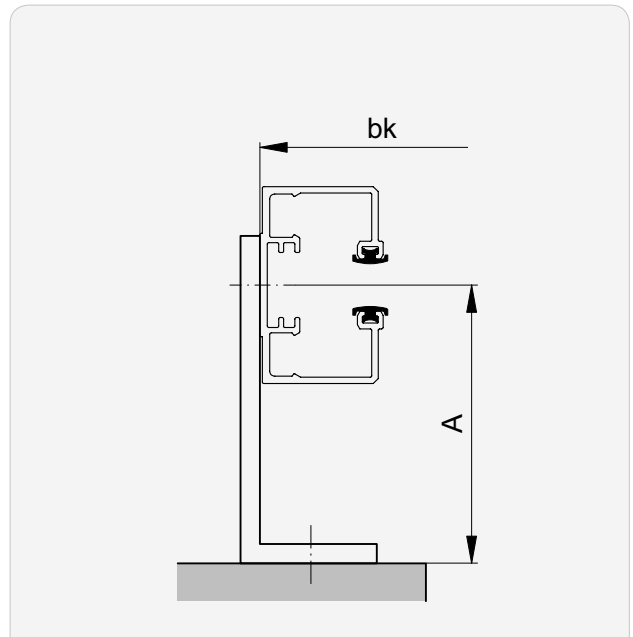

Bracket inwards

Continuous fastening bracket for types Bd and Cd

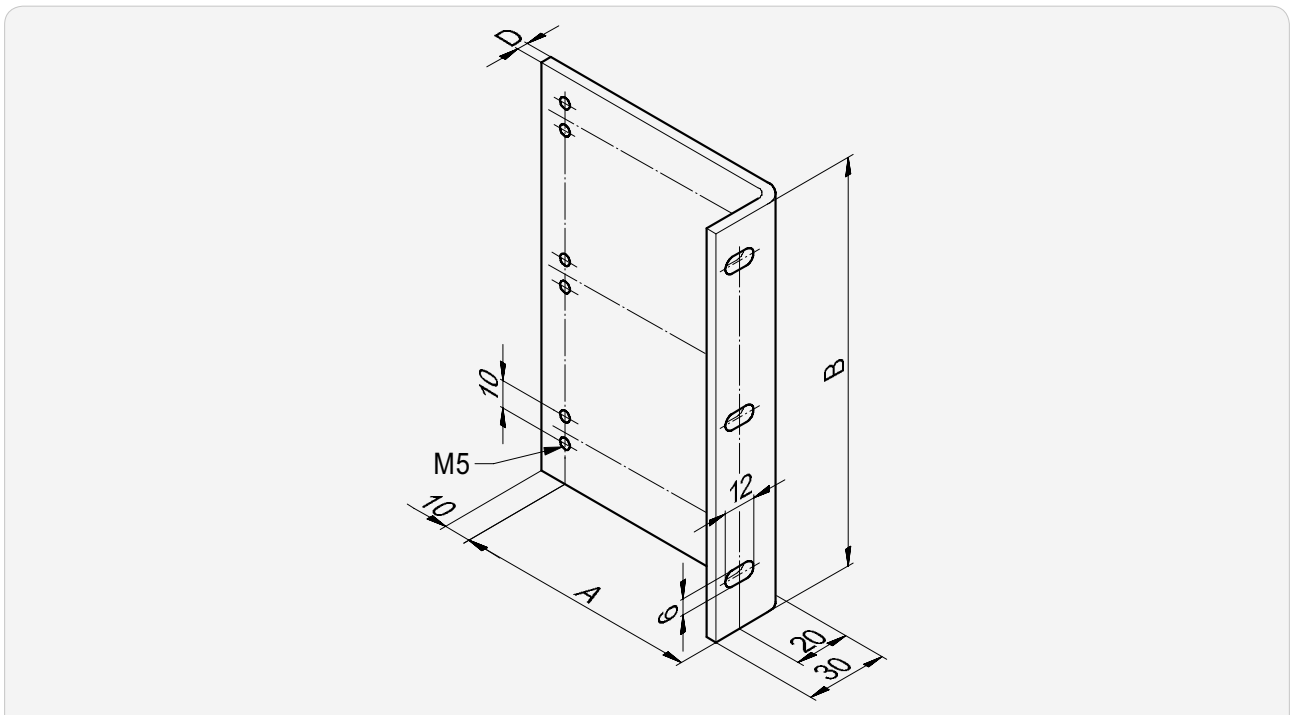

A*
20...300

D
always 4

* in 5 mm steps

►► Guide rail fastenings (principle)

E|F Installation with fastening lug

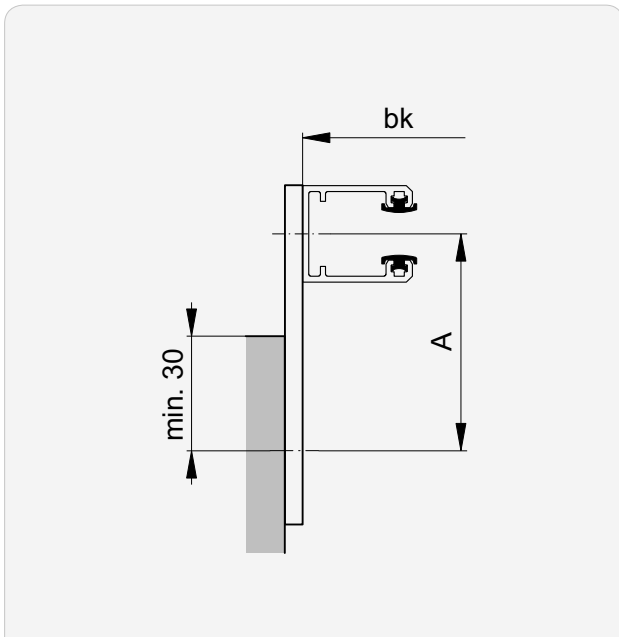

inwards / outwards

H Installation with spacer

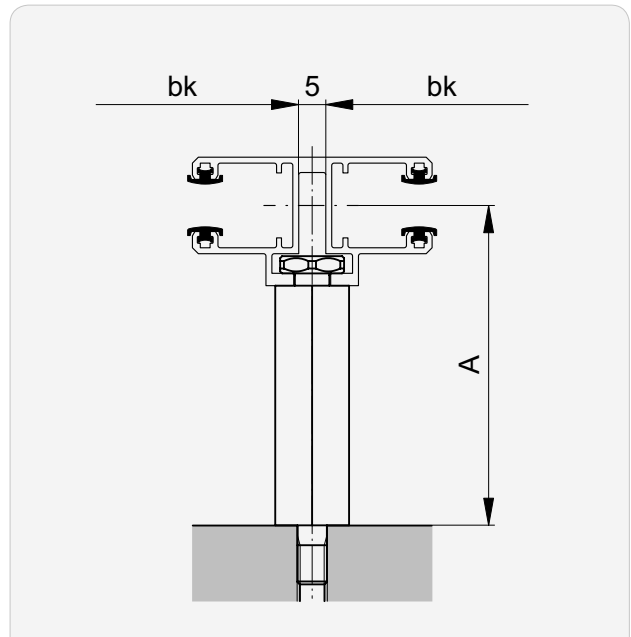

Only with guide type D

Fastening lug for type E | F

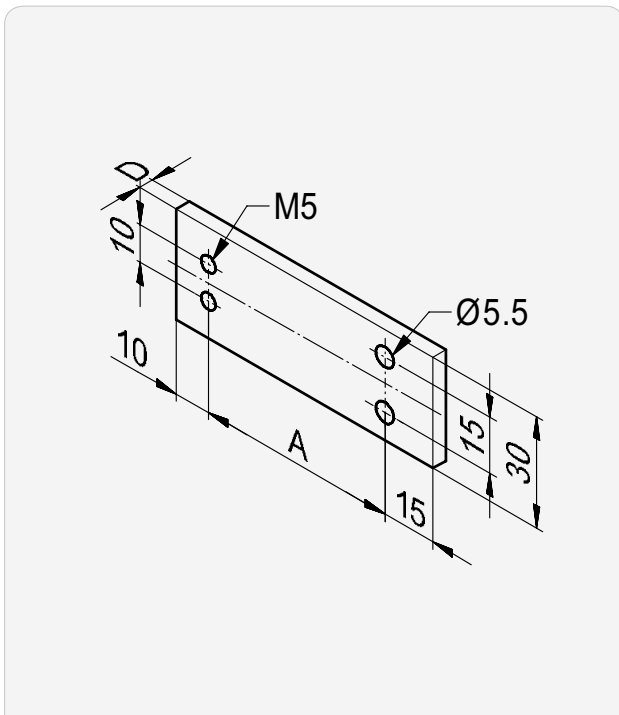

A*	D
50... 115	4
120... 125	5

* in 5 mm steps

Spacer for type H

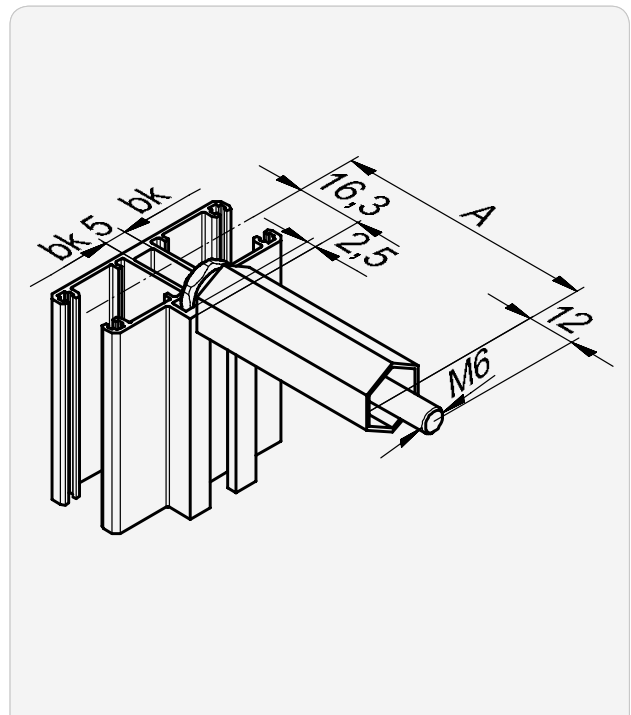

A
35... 115

►► Guide rail fastenings (principle)

Kv Installation with adjustable console

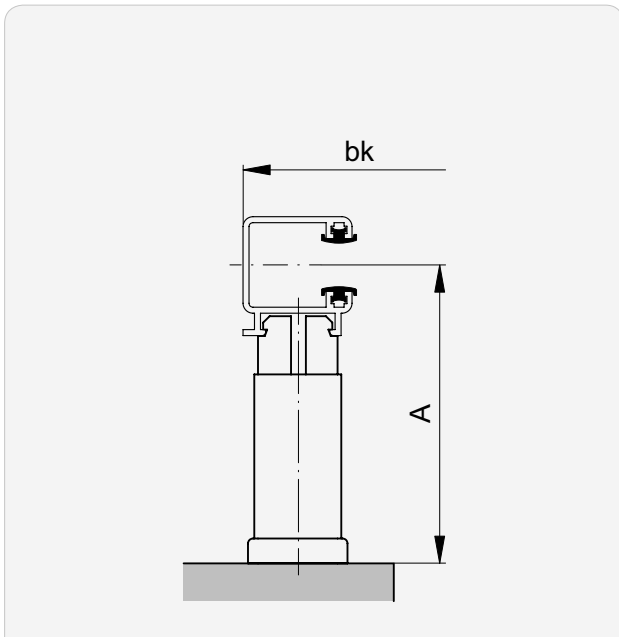

Only with guide type C | T | R

Console for type Kv

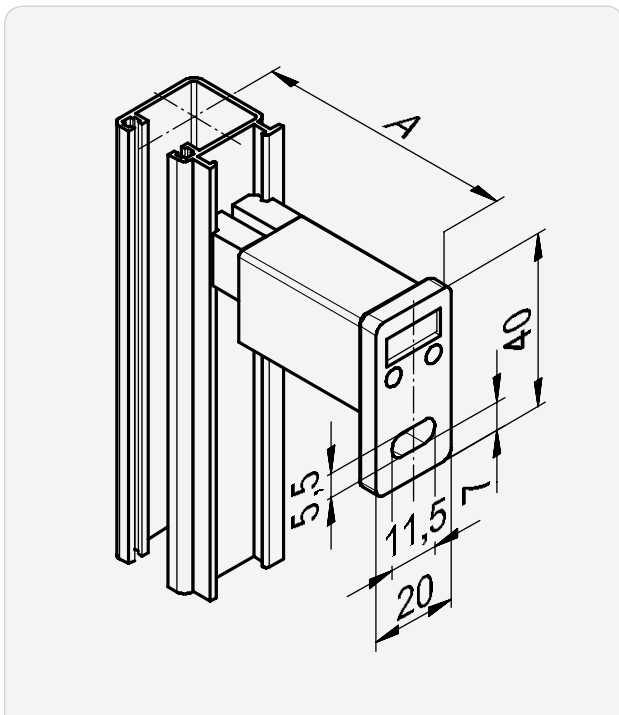

A	A
60... 75	121... 135
76... 90	136... 150
91... 105	151... 165
106... 120	166... 180
	181... 195

►► Guide rail fastenings (principle)

M Installation with centre bracket

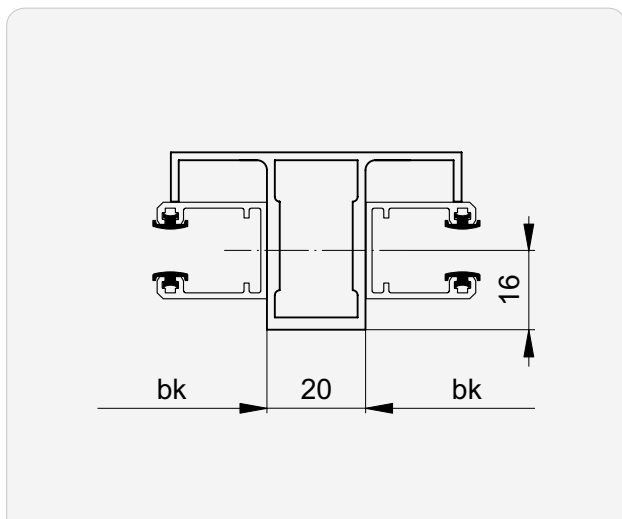

i Only with guide type E
Length = Guide length

Principle

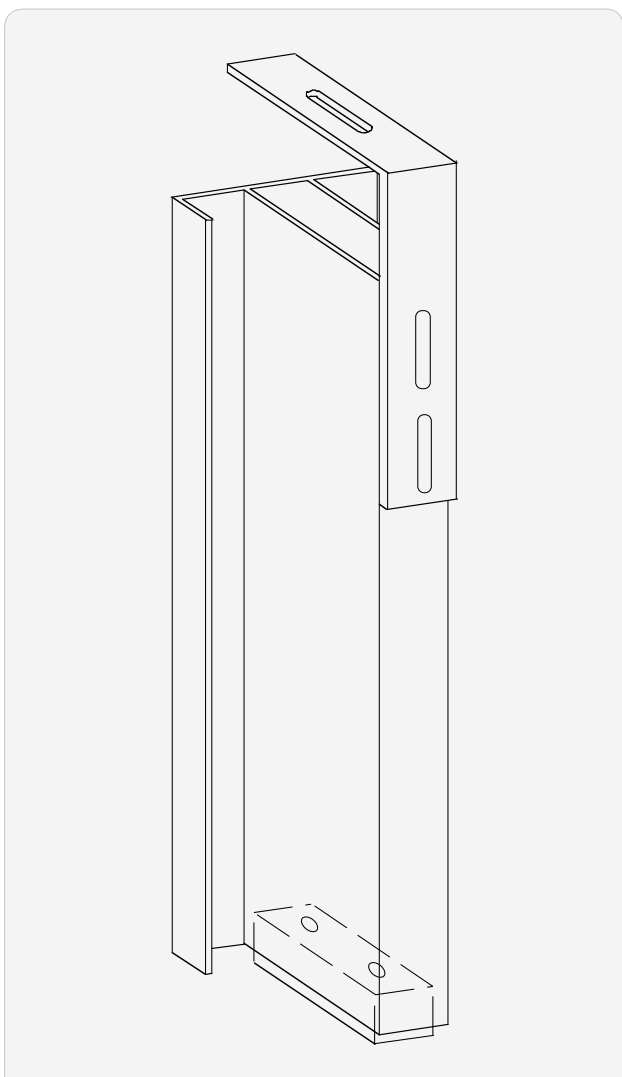

Fastening bracket above centre bracket

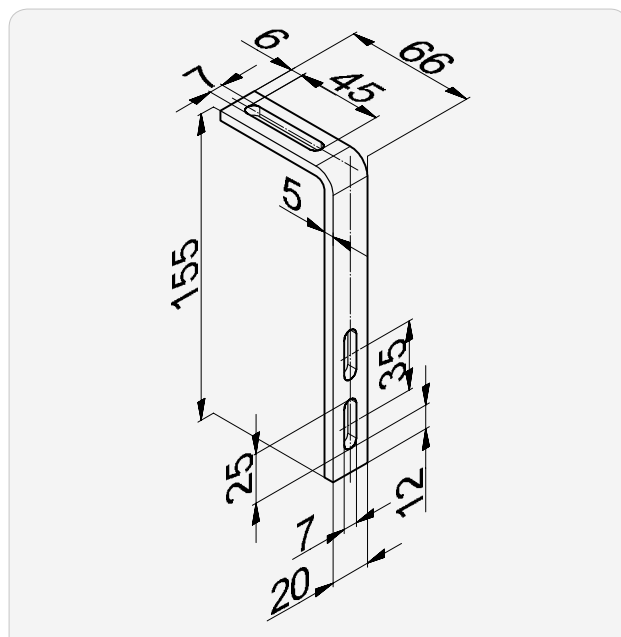

Fastening square below for centre bracket

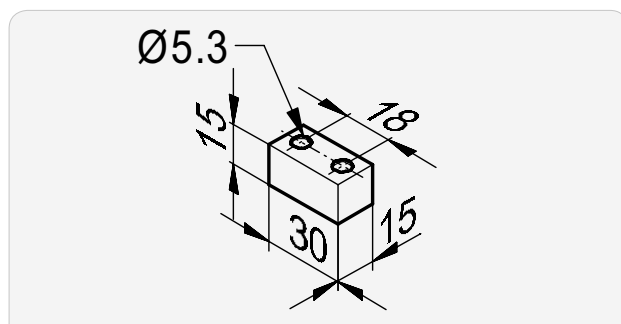

►► Guide rail fastenings (principle)

T Installation with T-bracket

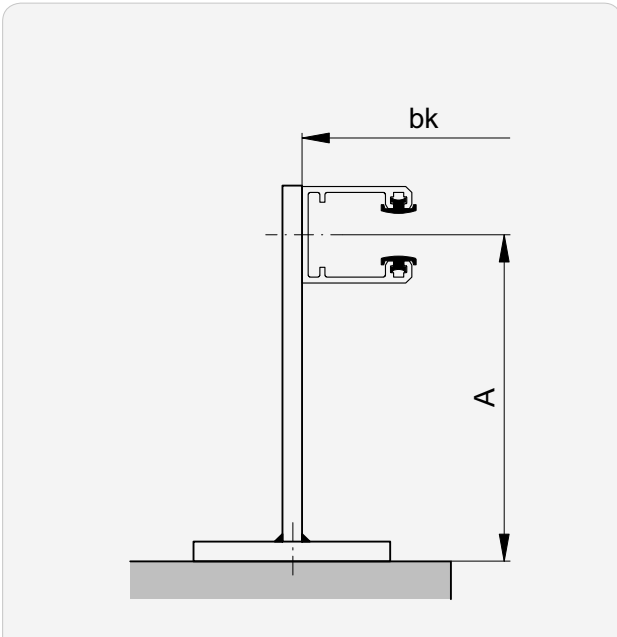

Tv Installation with adjustable T-bracket

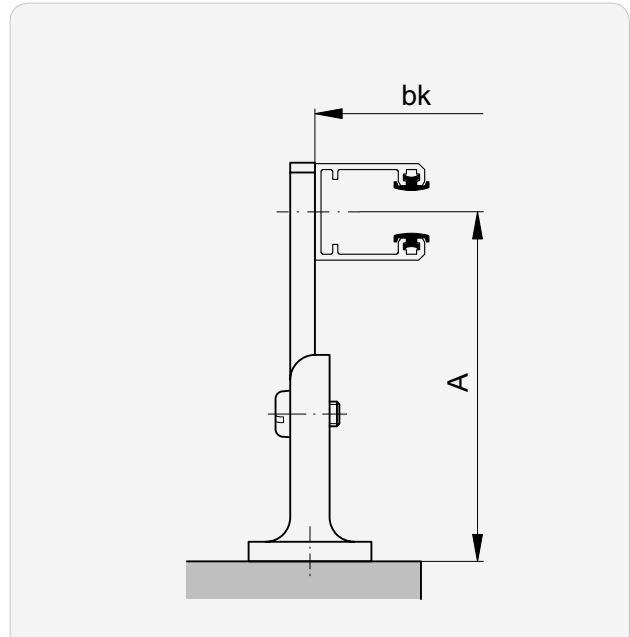

T-bracket for type T

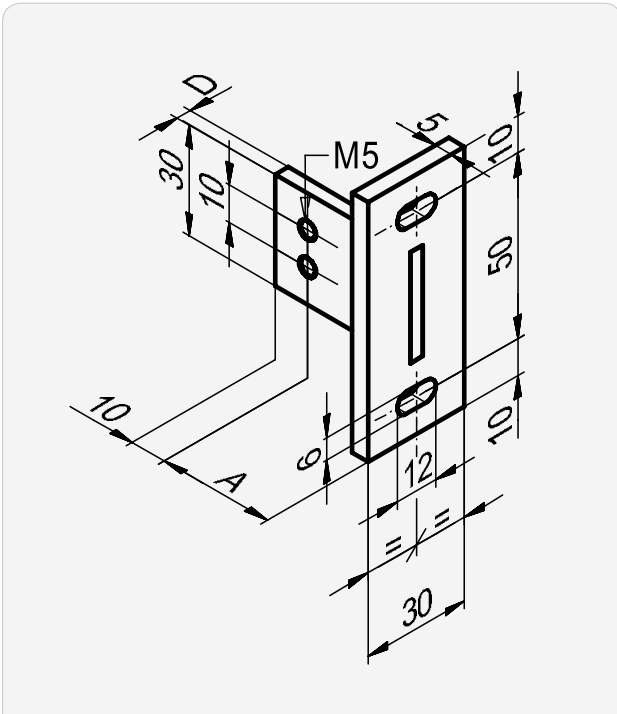

A*	D
20... 115	4
120... 215	5

* in 5 mm steps

T-bracket adjustable for type Tv

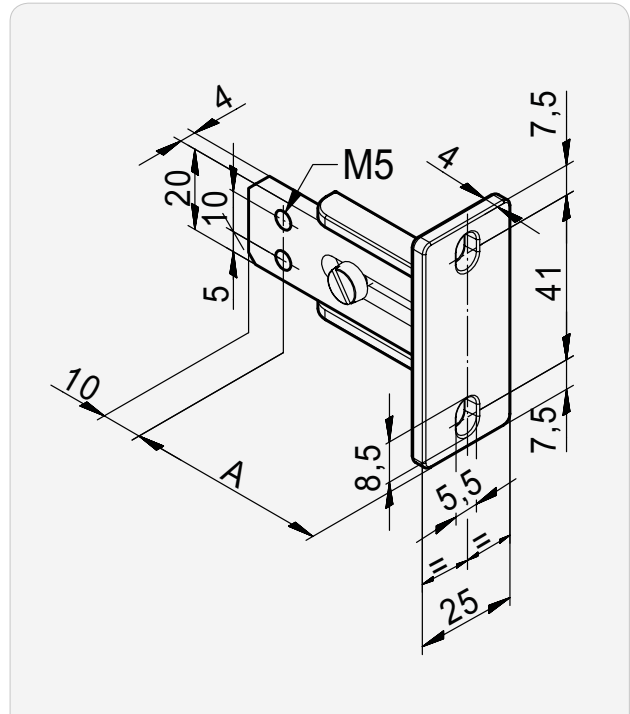

A
50... 68
69... 87
88... 106
107... 115

►► Guide rail fastenings (principle)

V Installation with one bracket

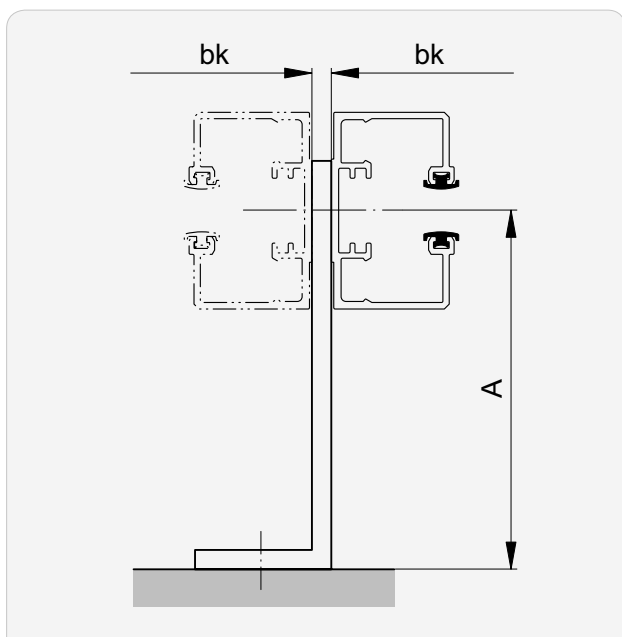

The blind on the right uses the fastening for the blind on the left.

Wv Installation with adjustable bracket

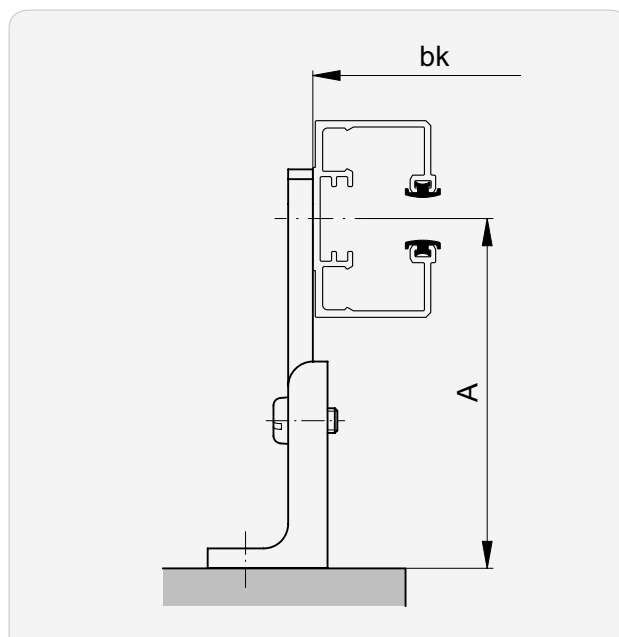

W-bracket adjustable for type Wv

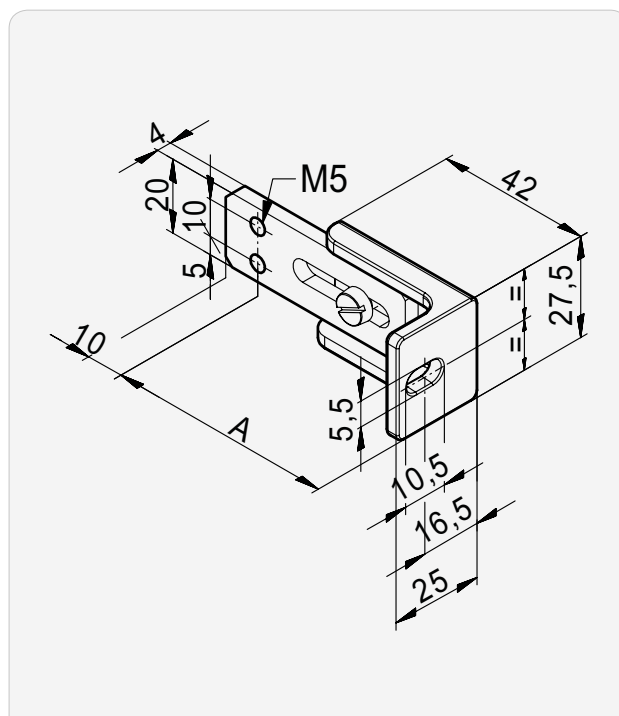

A

50...68

69...87

88...106

107...115

Guide extension and facet

Extension

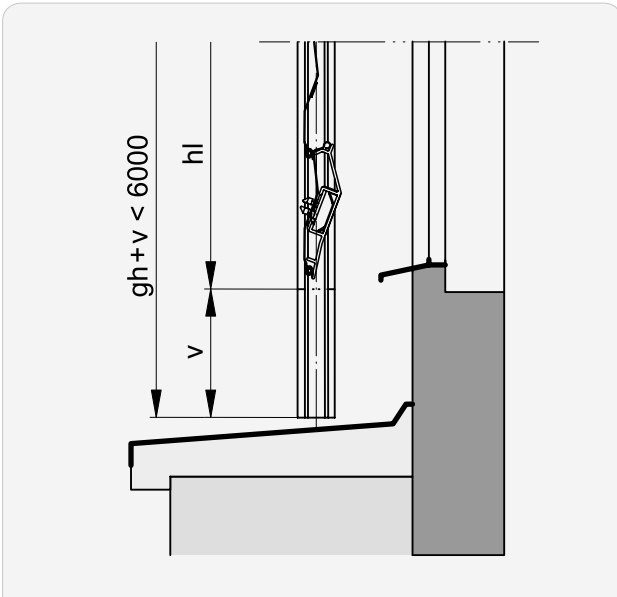

v
-35... 3000

Facet

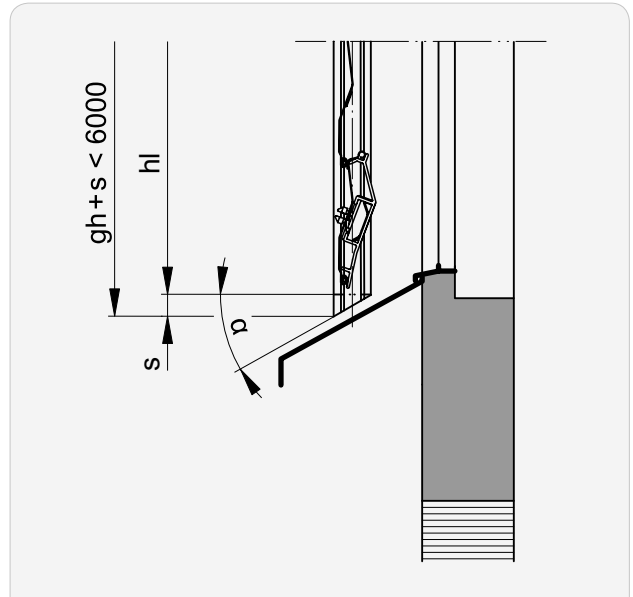

α
5... 50°

Extension and facet

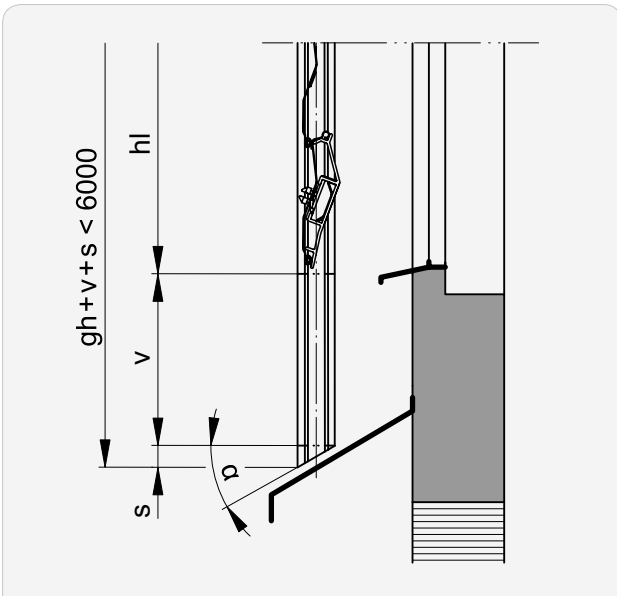

v
0... 3000

α
5... 50°

➔ Value for **s**..... 107

Angling at the guides

Type E | Single guide

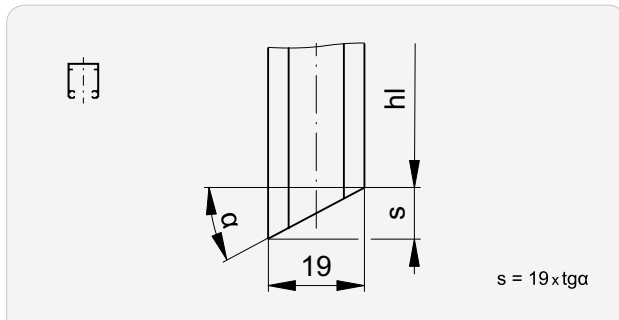

α	s	α	s	α	s	α	s	α	s
5	2	15	5	25	9	35	13	45	19
6	2	16	5	26	9	36	14	46	20
7	2	17	6	27	10	37	14	47	20
8	3	18	6	28	10	38	15	48	21
9	3	19	7	29	11	39	15	49	22
10	3	20	7	30	11	40	16	50	23
11	4	21	7	31	11	41	17		
12	4	22	8	32	12	42	17		
13	4	23	8	33	12	43	18		
14	5	24	8	34	13	44	18		

Type C | Single guide

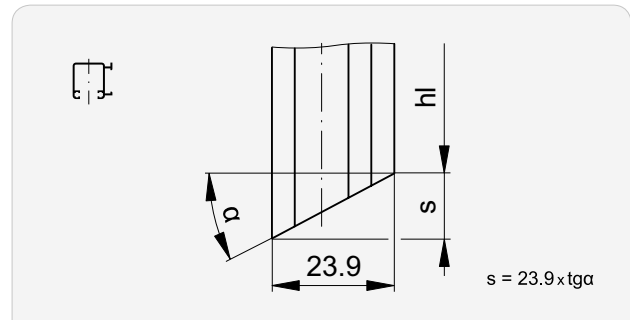

α	s	α	s	α	s	α	s	α	s
5	2	15	6	25	11	35	17	45	24
6	3	16	7	26	12	36	17	46	25
7	3	17	7	27	12	37	18	47	26
8	3	18	8	28	13	38	19	48	27
9	4	19	8	29	13	39	19	49	27
10	4	20	9	30	14	40	20	50	28
11	5	21	9	31	14	41	21		
12	5	22	10	32	15	42	22		
13	6	23	10	33	16	43	22		
14	6	24	11	34	16	44	23		

Type L | Fix guide

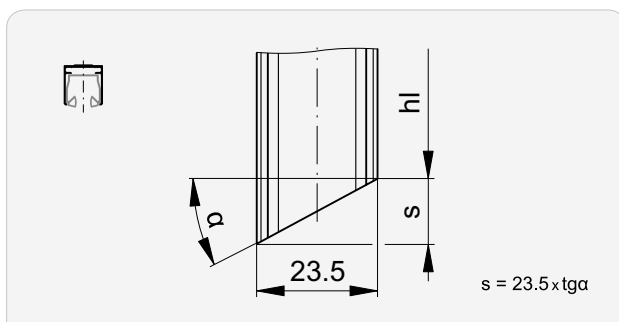

α	s	α	s	α	s	α	s	α	s
5	2	15	6	25	11	35	16	45	24
6	2	16	7	26	11	36	17	46	24
7	3	17	7	27	12	37	18	47	25
8	3	18	8	28	12	38	18	48	26
9	4	19	8	29	13	39	19	49	27
10	4	20	9	30	14	40	20	50	28
11	5	21	9	31	14	41	20		
12	5	22	9	32	15	42	21		
13	5	23	10	33	15	43	22		
14	6	24	10	34	16	44	23		

Type F | Fix guide

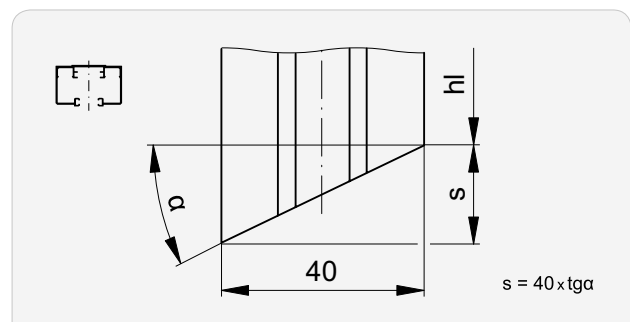

α	s	α	s	α	s	α	s	α	s
5	3	15	11	25	19	35	28	45	40
6	4	16	11	26	20	36	29	46	41
7	5	17	12	27	20	37	30	47	43
8	6	18	13	28	21	38	31	48	44
9	6	19	14	29	22	39	32	49	46
10	7	20	15	30	23	40	34	50	48
11	8	21	15	31	24	41	35		
12	9	22	16	32	25	42	36		
13	9	23	17	33	26	43	37		
14	10	24	18	34	27	44	39		

►► Angling at the guides

Type T | Double guide

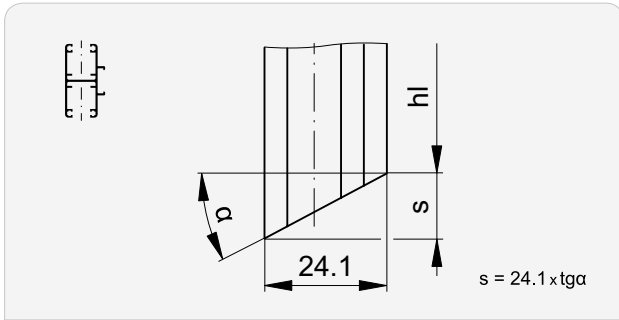

α	s	α	s	α	s	α	s	α	s
5	2	15	6	25	11	35	17	45	24
6	3	16	7	26	12	36	18	46	25
7	3	17	7	27	12	37	18	47	26
8	3	18	8	28	13	38	19	48	27
9	4	19	8	29	13	39	20	49	28
10	4	20	9	30	14	40	20	50	29
11	5	21	9	31	14	41	21		
12	5	22	10	32	15	42	22		
13	6	23	10	33	16	43	22		
14	6	24	11	34	16	44	23		

Type D | Double guide

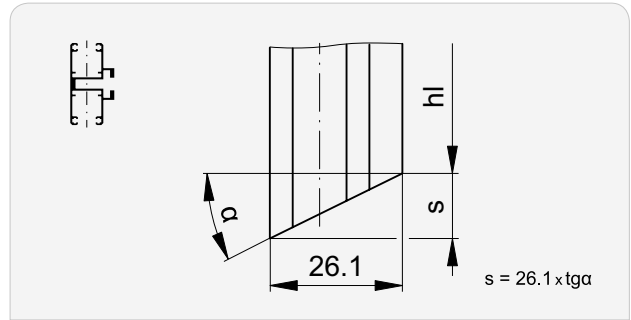

α	s	α	s	α	s	α	s	α	s
5	2	15	7	25	12	35	18	45	26
6	3	16	7	26	13	36	19	46	27
7	3	17	8	27	13	37	20	47	28
8	4	18	8	28	14	38	20	48	29
9	4	19	9	29	14	39	21	49	30
10	5	20	9	30	15	40	22	50	31
11	5	21	10	31	16	41	23		
12	6	22	11	32	16	42	24		
13	6	23	11	33	17	43	24		
14	7	24	12	34	18	44	25		

Type R | Curved double guide

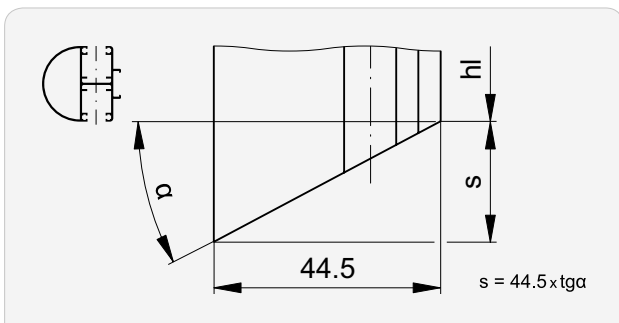

α	s	α	s	α	s	α	s	α	s
5	4	15	12	25	21	35	31	45	45
6	5	16	13	26	22	36	32	46	46
7	5	17	14	27	23	37	34	47	48
8	6	18	14	28	24	38	35	48	50
9	7	19	15	29	25	39	36	49	51
10	8	20	16	30	26	40	37	50	53
11	9	21	17	31	27	41	39		
12	9	22	18	32	28	42	40		
13	10	23	19	33	29	43	42		
14	11	24	20	34	30	44	43		

Guide rail cut-outs in windowsill area

Guide type						
C	D	E	F	L	R	T
-	-	●	●	●	-	-

Rear cut-out | without/with extension

Without extension

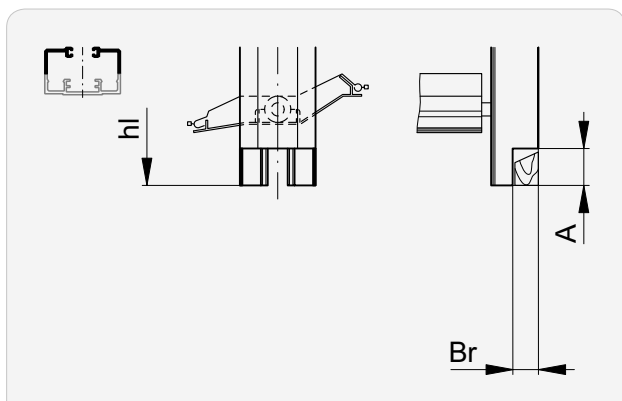

A	Guide type	Br		
		E	F	L*
0 ... 25		2 ... 3	2 ... 4	2 ... 4
		5 ... 12	9 ... 12	6

* FL ≥ 630

Extension | $v \leq A$

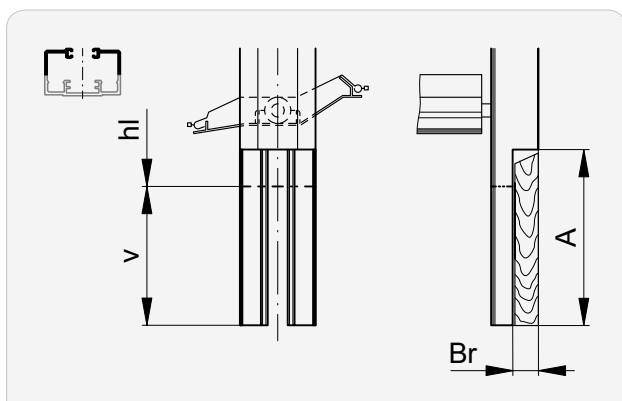

A	Guide type	Br		
		E	F	L*
0 ... 25		2 ... 3	2 ... 4	2 ... 4
		5 ... 12	9 ... 12	6

* FL ≥ 630

Extension | $v > A$

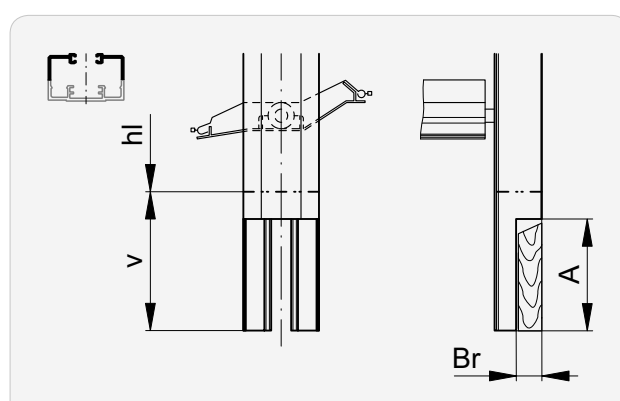

A	Guide type	Br		
		E	F	L*
0 ... 25		2 ... 3	2 ... 4	2 ... 4
		5 ... 12	9 ... 12	6

* FL ≥ 630

v Guide rail extension: 0 ... 3000

►► Guide rail cut-outs in windowsill area

Inner cut-out | without/with extension

Without extension

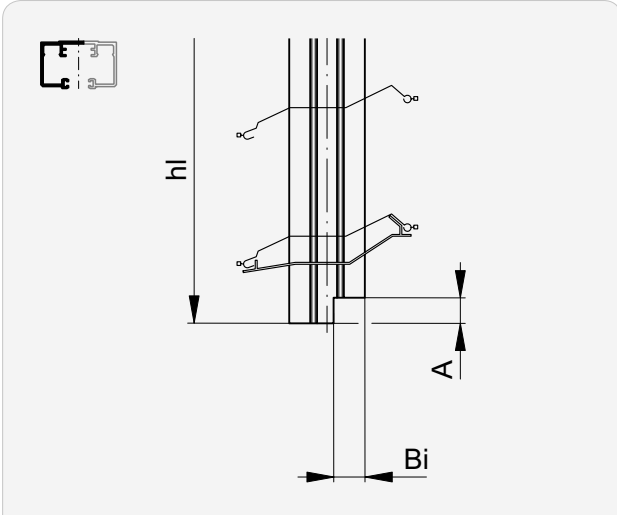

A	Guide type	Bi		L*
		E	F	
0...25		6...12	3...10	8...12

* FL ≥ 630

Extension | $v \leq A$

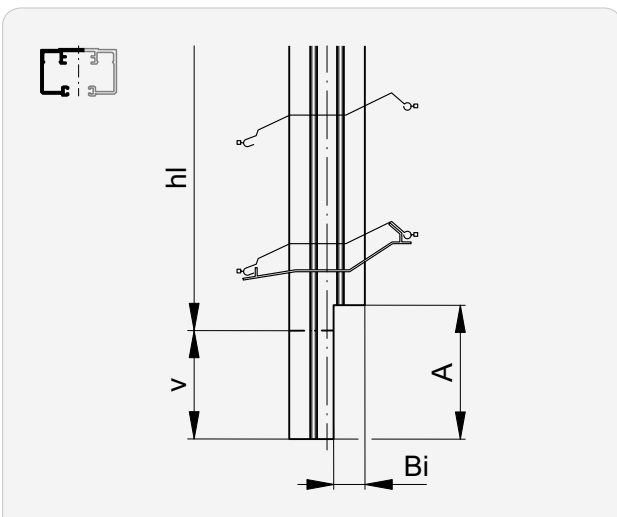

A	Guide type	Bi		L*
		E	F	
0...25		6...12	3...10	8...12

* FL ≥ 630

Extension | $v > A$

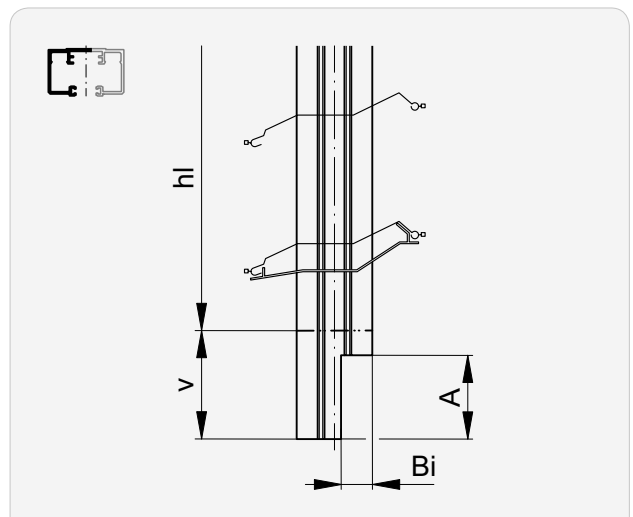

A	Guide type	Bi		L*
		E	F	
0...25		6...12	3...10	8...12

* FL ≥ 630

v Guide rail extension: 0...3000

Guide rail end for suspended guide rails

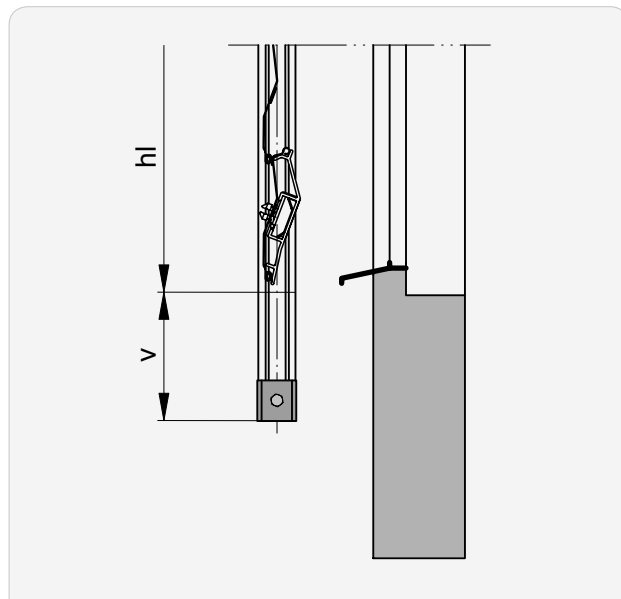
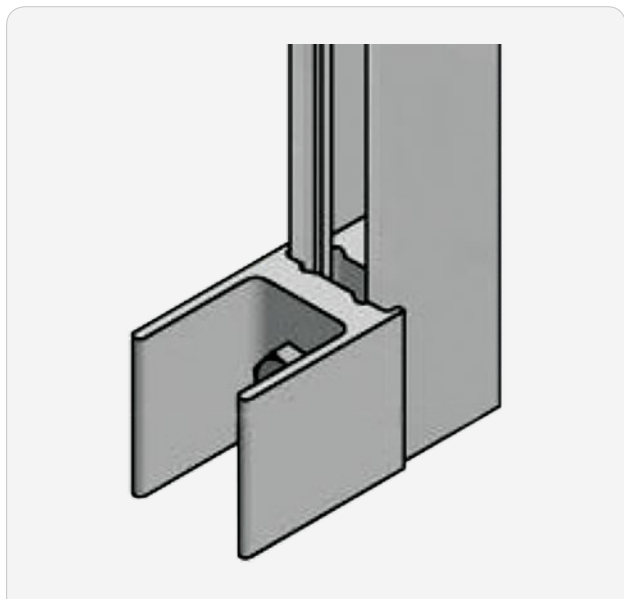

Guide type						
C	D	E	F	L	R	T
●	●	●	●	●	●	●

L*	v
70	≥30

* Guide fastening with local brackets.

Installation window

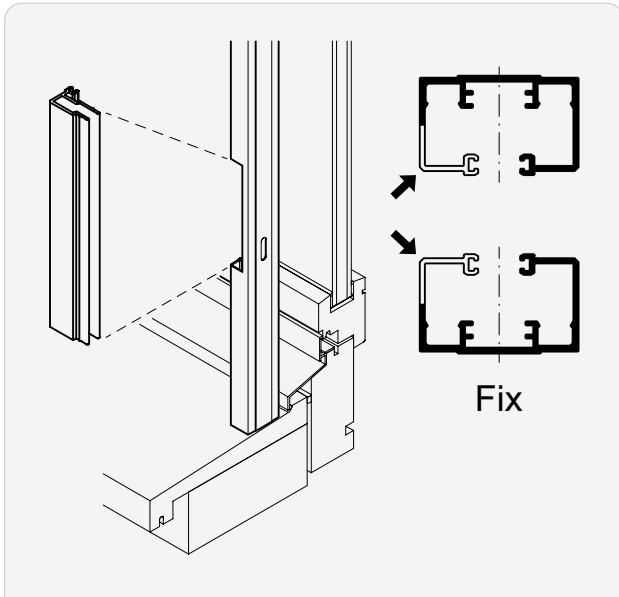

Without extension

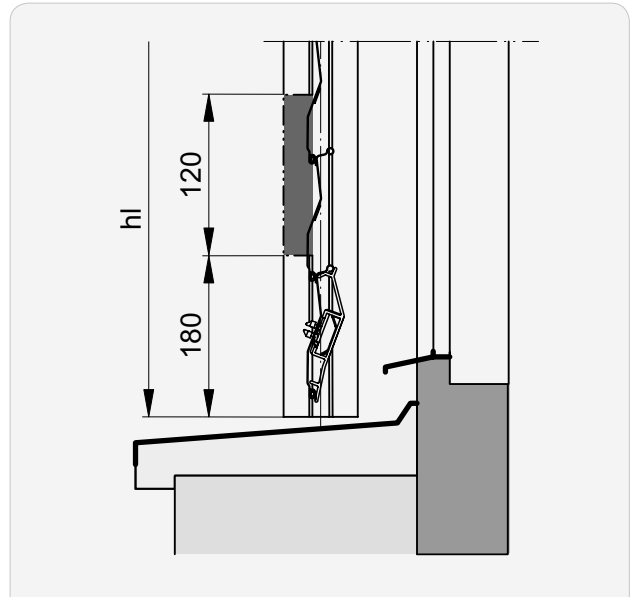

With extension

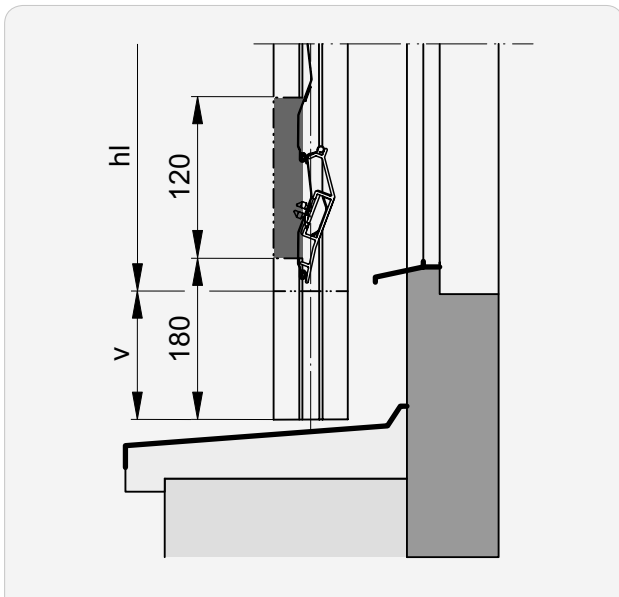

With extension and facet

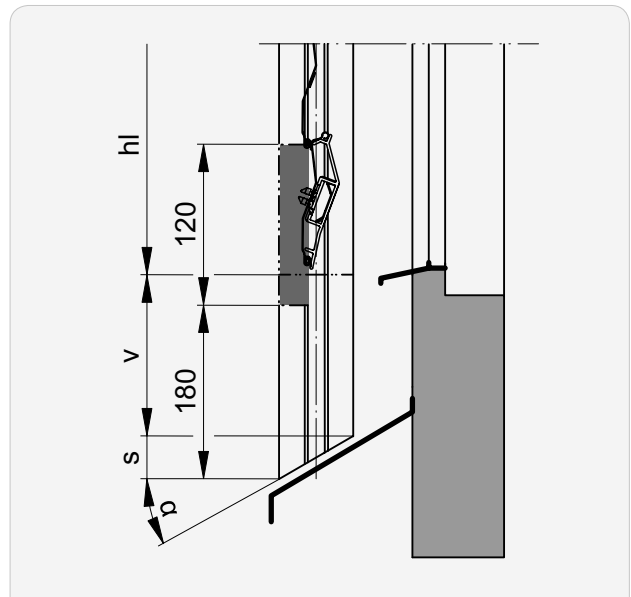

- s** Faceting (guide rail width x $\tan \alpha$)
- v** Guide rail extension: max. 3000

Fastening points

Without extension

Z	AS
≤ 1500	2
1501 ... 2700	3
2701 ... 3900	4
3901 ... 5100	5
> 5100	6

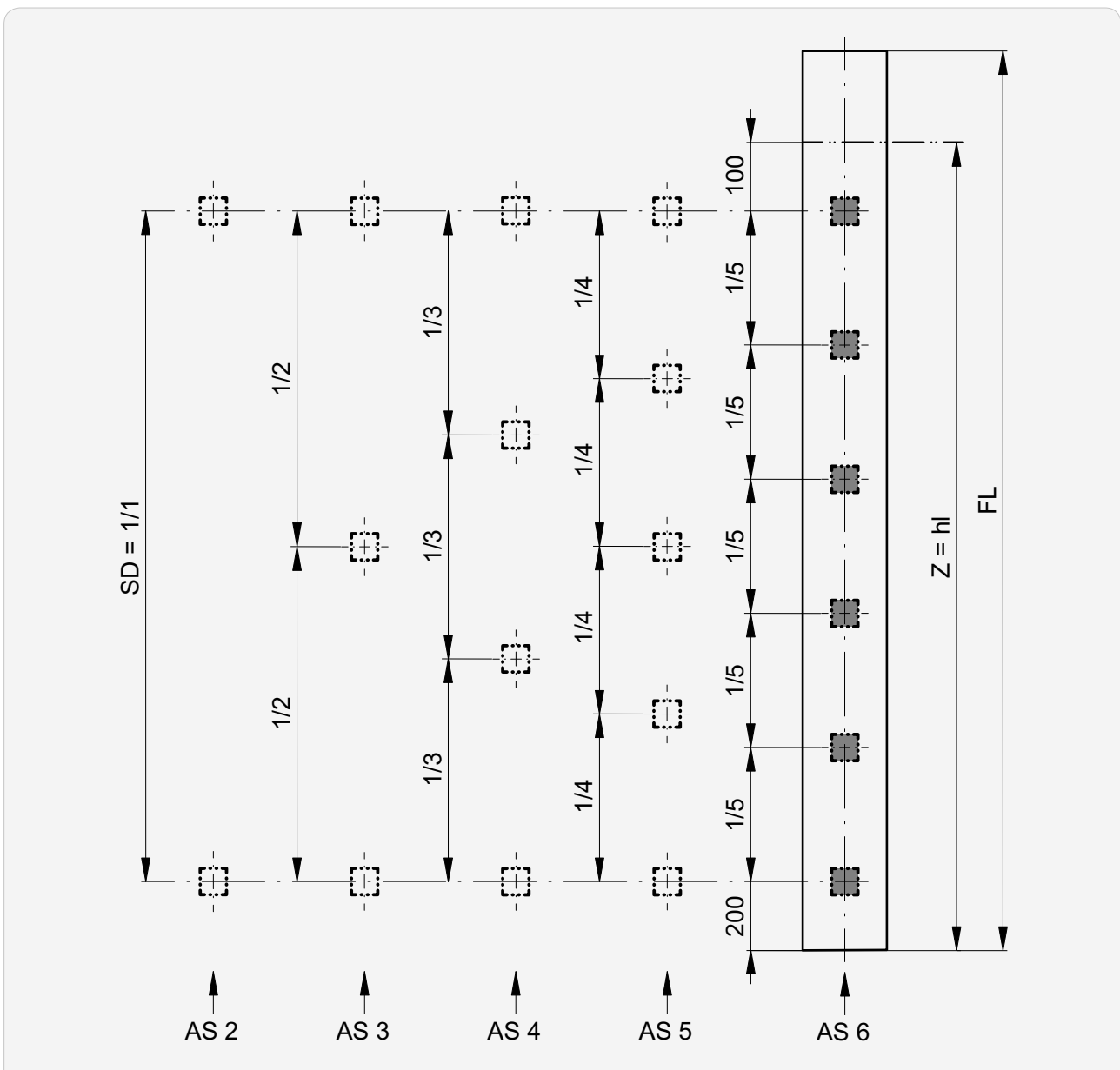

AS Number of slits

SD Slot spacing: max. 1200

►► Fastening points

With guide rail extension

Z	AS
≤ 1500	2
1501 ... 2700	3
2701 ... 3900	4
3901 ... 5100	5
> 5100	6

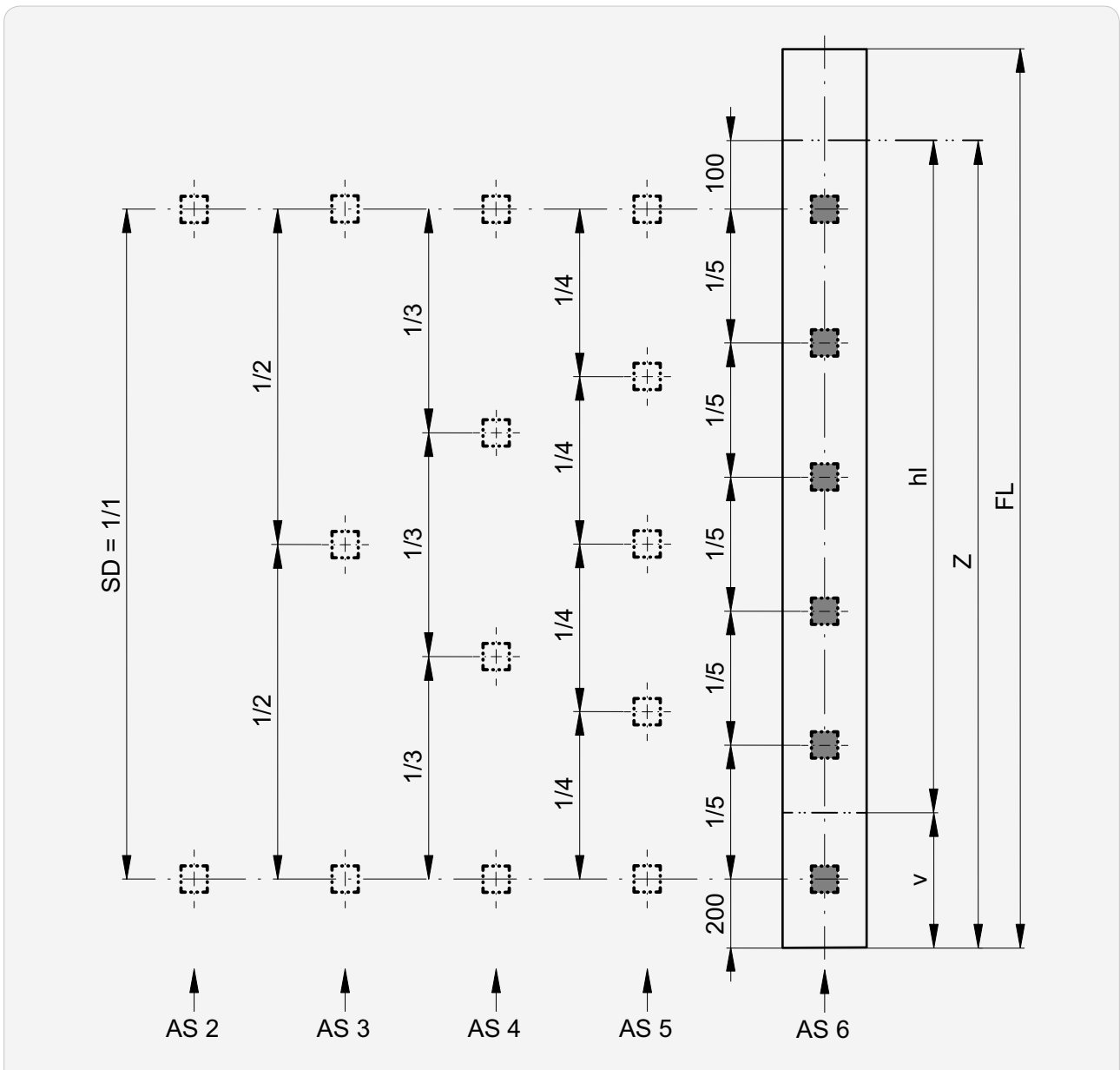

AS Number of slits
SD Slot spacing: max. 1200

v Guide rail extension: max. 3000

► Guide extension and facet.....	106	► Installation window.....	112
► Guide rail fastenings	98		

►► Fastening points

With facet

Z	AS
≤ 1500	2
1501 ... 2700	3
2701 ... 3900	4
3901 ... 5100	5
> 5100	6

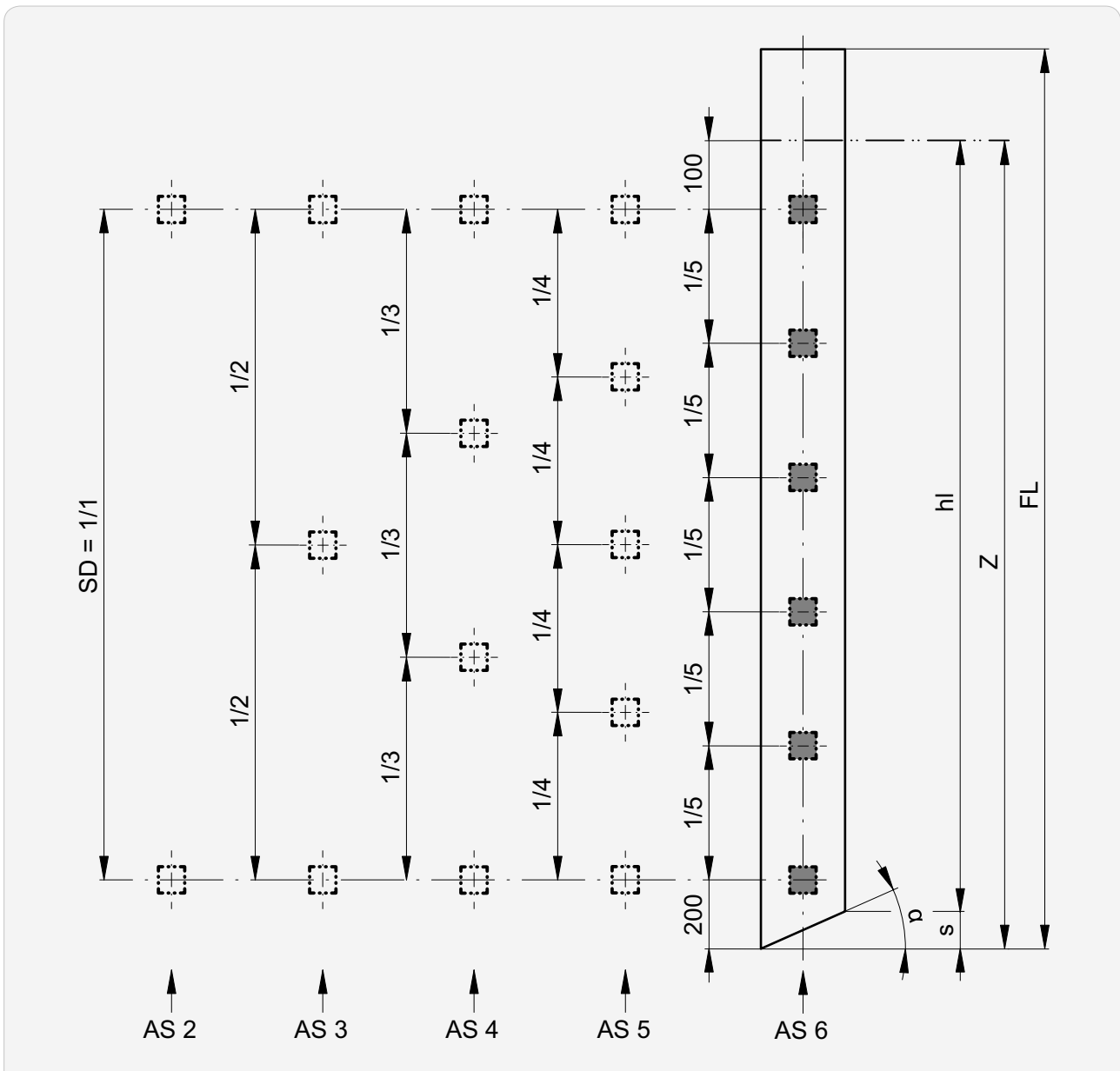

AS Number of slits

SD Slot spacing: max. 1200

s Faceting (guide rail width x tgα)

➡ Guide extension and facet 106
 ➡ Guide rail fastenings 98

➡ Installation window 112

►► Fastening points

With guide rail extension and facet

Z	AS
≤ 1500	2
1501 ... 2700	3
2701 ... 3900	4
3901 ... 5100	5
> 5100	6

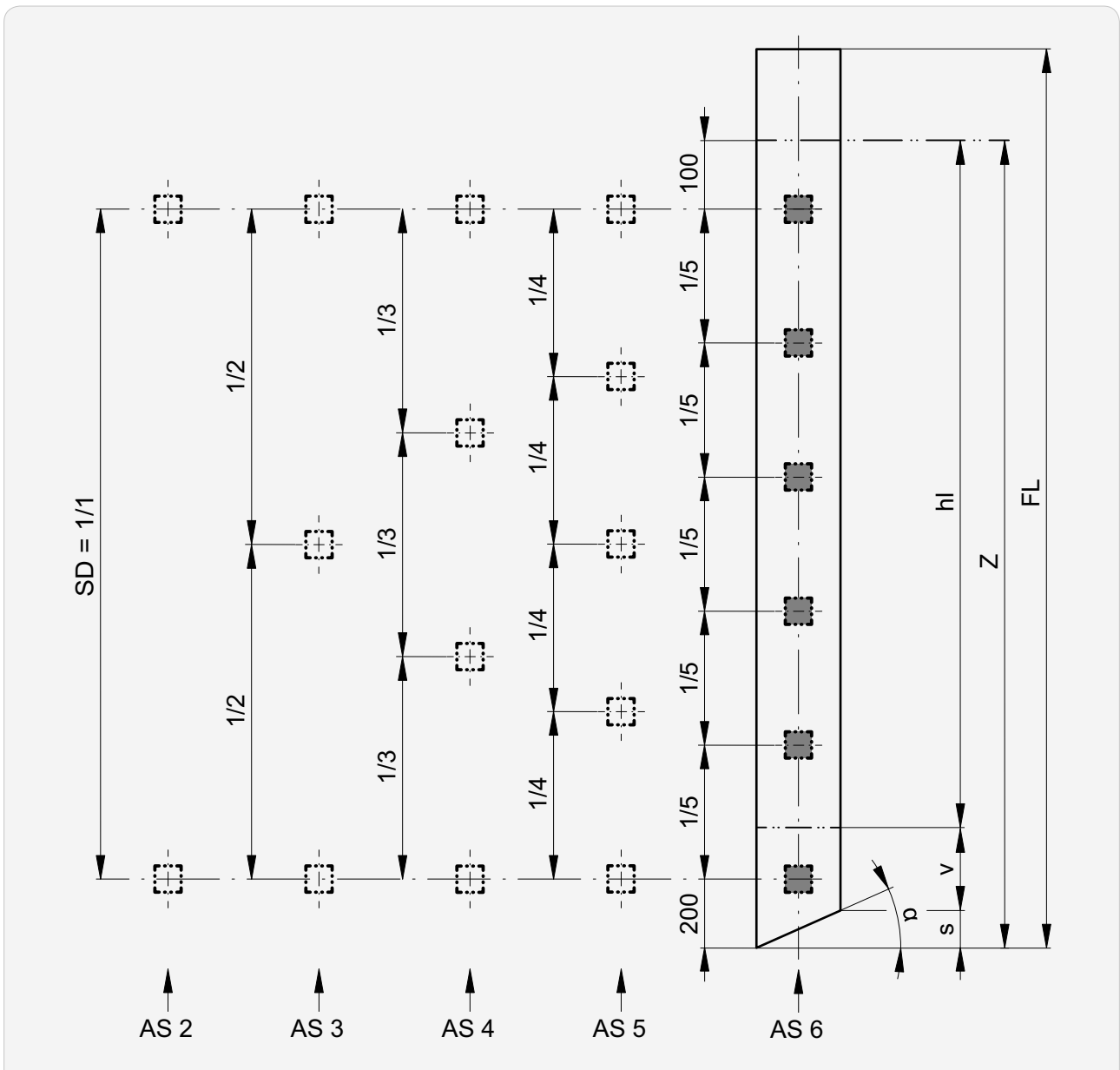

AS Number of slits

s Faceting (guide rail width x tgα)

SD Slot spacing: max. 1200

v Guide rail extension: max. 3000

► Guide extension and facet 106

► Guide rail fastenings 98

► Installation window 112

Connected systems

System width

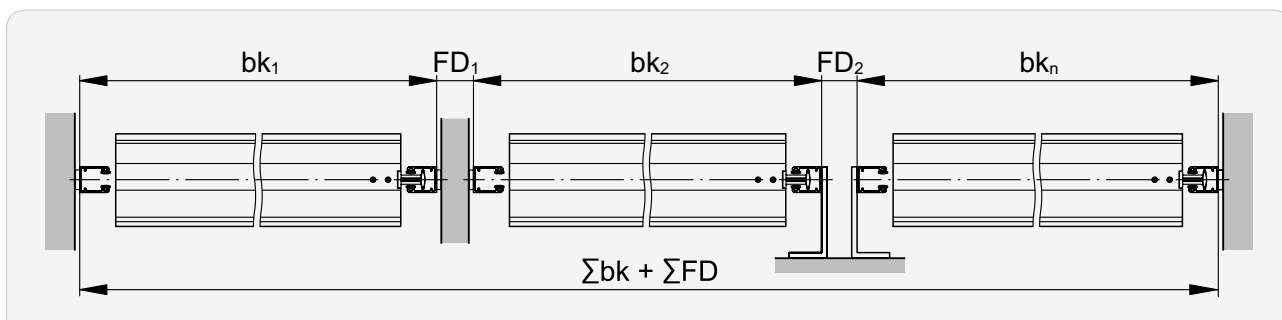

Distance between guides FD

Single guide | Fix guide

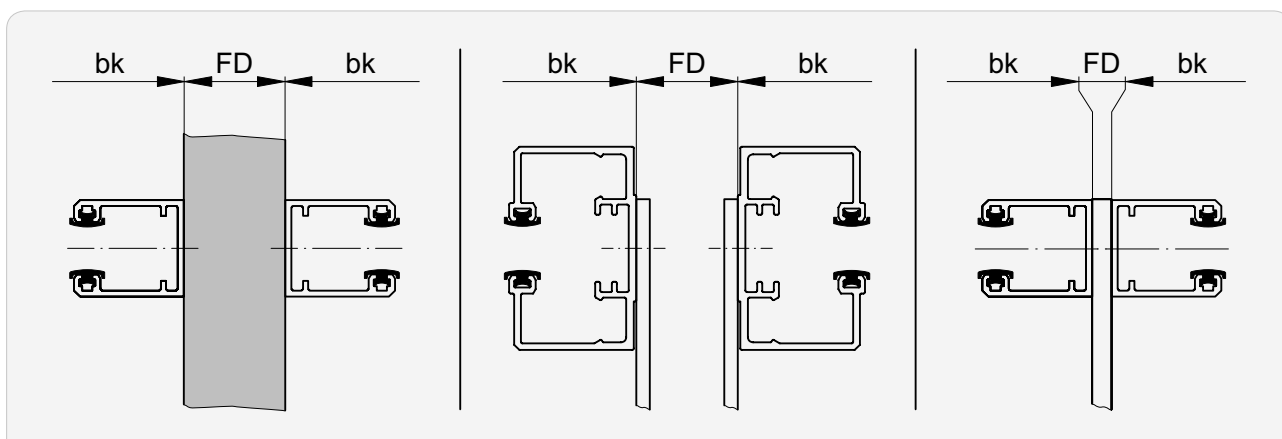

FD min.

5

FD max.

1000

Double guide

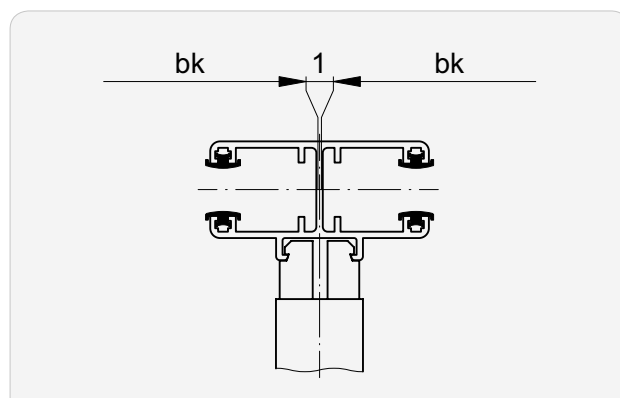
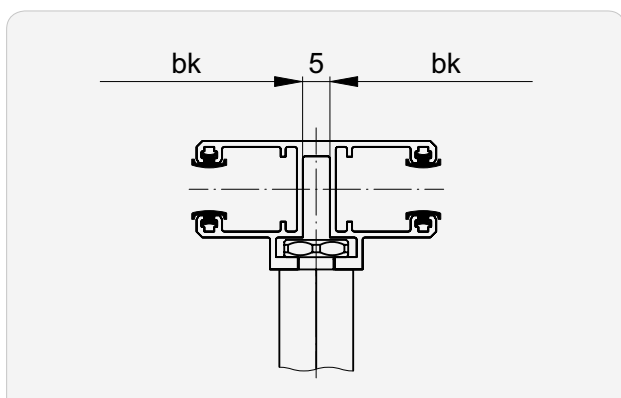

➔ Opening for connected blinds 118

►► Connected systems

Drive position

Gearbox

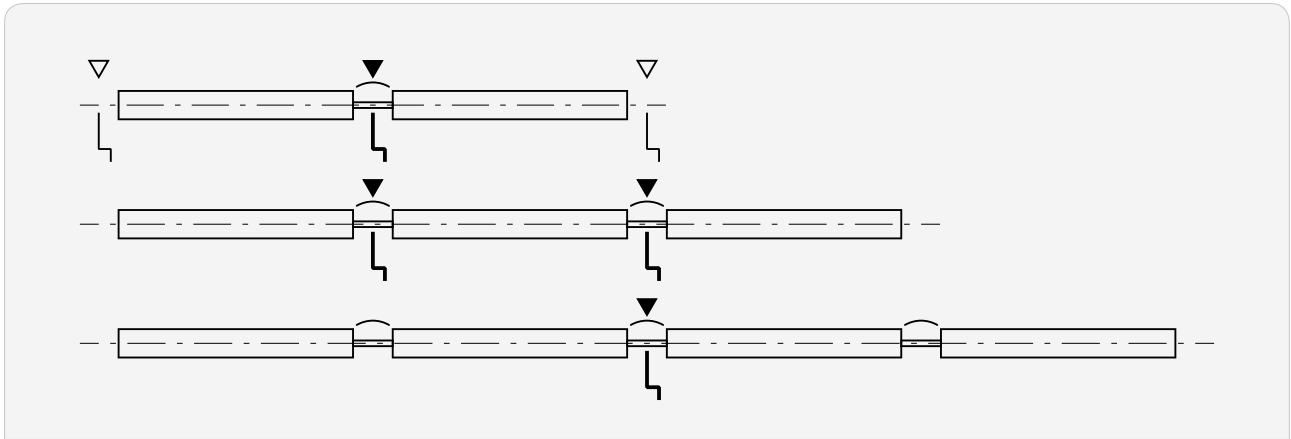

Motor

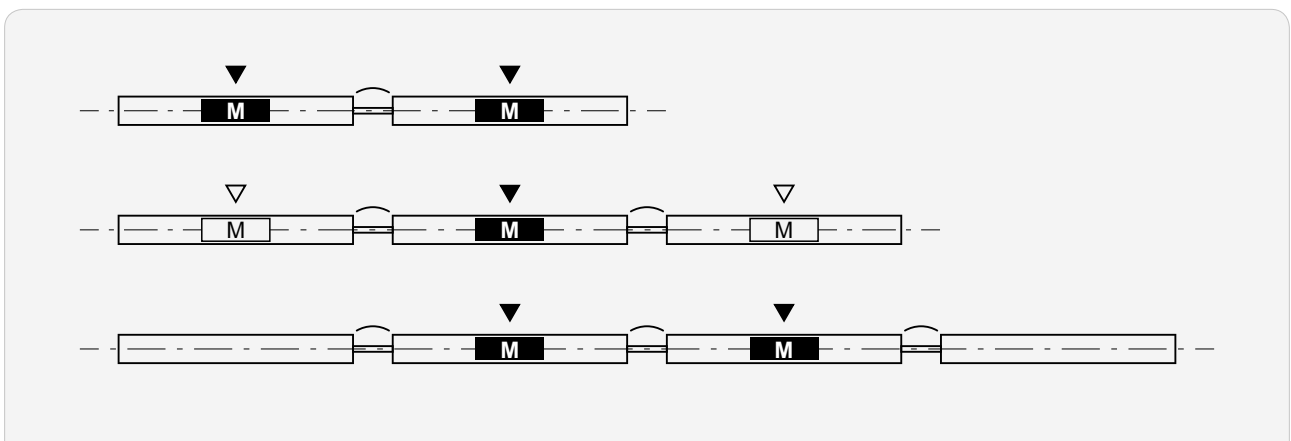

▼ Standard drive position

▽ Possible drive position

Opening for connected blinds

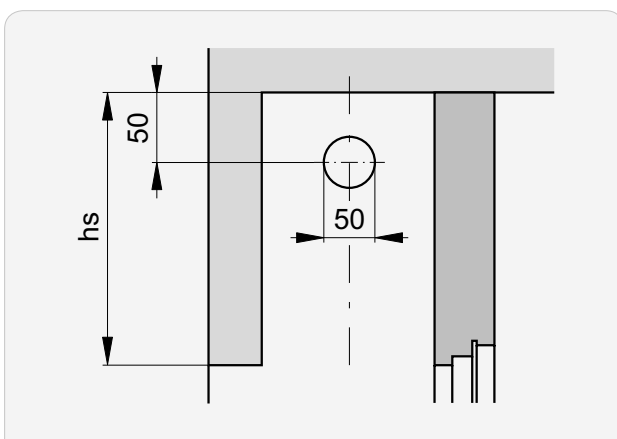

Technical data of motors

Performance characteristics

Type	Limit switch		M [Nm]	n [1/min.]	P [W]	I [A]
	Type	Number of				
Standard						
Elero						
ES...	06.01	mechanical	6	26	110	0.50
	09.01		9		170	0.75
EO...	20.01		20		190	1.05
ES...	06.51	mechanical	6	26	110	0.50
	09.51		9		170	0.75
EO...	20.51		20		190	1.05
Option						
Somfy						
SH...	06.01	mechanical	6	24	95	0.40
	10.01		10		110	0.65
	18.01		18		155	1.00
SW...	06.01		6		95	0.40
SI...	10.01	electronic	10	24	110	0.65
	18.01		18		155	1.00
Elero Comfort						
ECM...	06.01	electronic	6	26	115	0.50
	09.01		9		156	0.68
	06.51		3		115	0.50
	09.51		9		156	0.68
ECB...	06.01	electronic	6	26	115	0.50
	09.01		9		156	0.68
	06.51		3		115	0.50
	09.51		9		156	0.68
Geiger AIR						
GA...	06.01	electronic	6	26	93	0.40
	06.10		10		135	0.60
	06.20		20		190	0.85

I Current consumption

M Torque

n Rotational speed

P Power consumption



Lamisol® III System

Limit dimensions Lamisol® III System Profil	122
Limit dimensions Lamisol® III System Box	122
Built-in System	123
Installation system with Box	124
Header dimensions Heights of package	125
Slat profiles	126
End rails	126
Beginning distance Slot spacing	127
Orientation of cable outlet	128
Guide rails	129
Sections Details	130
Vertical connections Standard motor position	132
Guide rail installation (principle)	137
Guide rail fastenings (principle)	138
Guide extension and facet	139
Fastening points Lamisol® III System Profil	141
Fastening points Lamisol® III System Box	145
Technical data of motors	149



Limit dimensions Lamisol® III System Profil

Single blind

Operation	Width min. (bk)	Width ¹ max. (bk)	Height min. (hl)	Height max. (hl)	Surface max. [m ²]
Motor drive	600 ³ 500 ⁴ 630 ²	4500 ³ 4550 ⁴	400 ³ 380 ⁴	4300 ³ 5000 ⁴ 4000 ²	10

Limit dimensions Lamisol® III System Box

Single blind

Operation	Width min. (bk)	Width ¹ max. (bk)	Height min. (gh)	Height max. (gh)	Surface max. [m ²]
Motor drive	600 ³ 500 ⁴ 630 ²	4000	590	4700 4379 ^{2,3} 4344 ^{2,4}	10

¹ For buildings and high-rise structures, which are exposed to high winds, this maximum value should be decreased as required. Also see wind classes data sheet.

² Radio motor Geiger AIR

³ Lamisol® III 70 System

⁴ Lamisol® III 90 System

Built-in System

Vertical section: Lamisol® III 70 System Profil

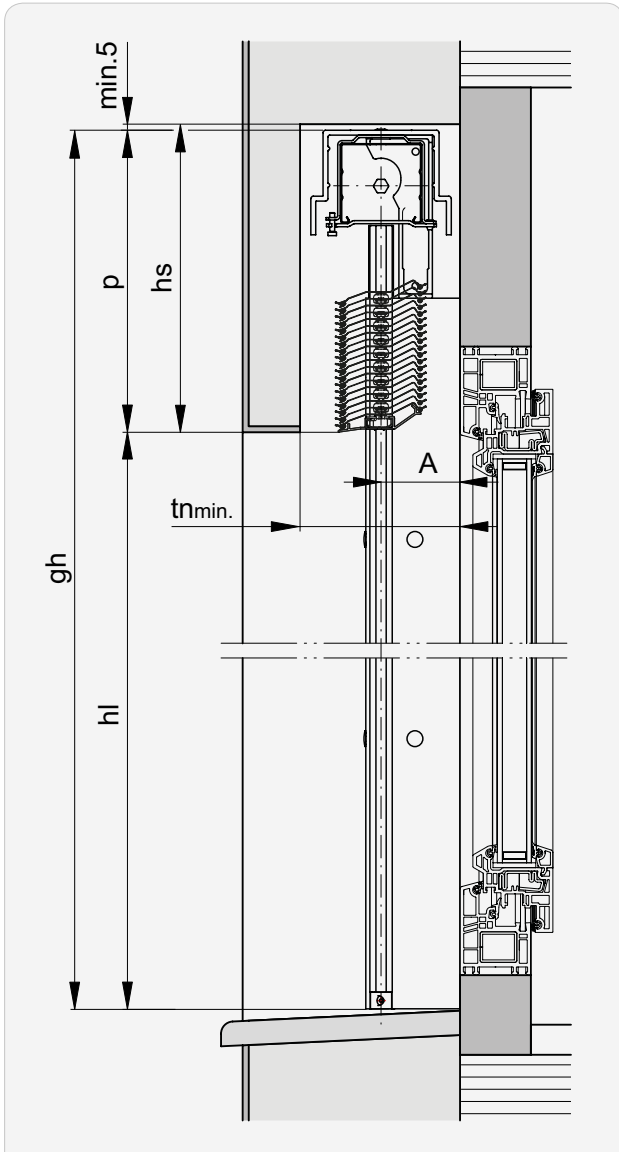

Vertical section: Lamisol® III 90 System Profil

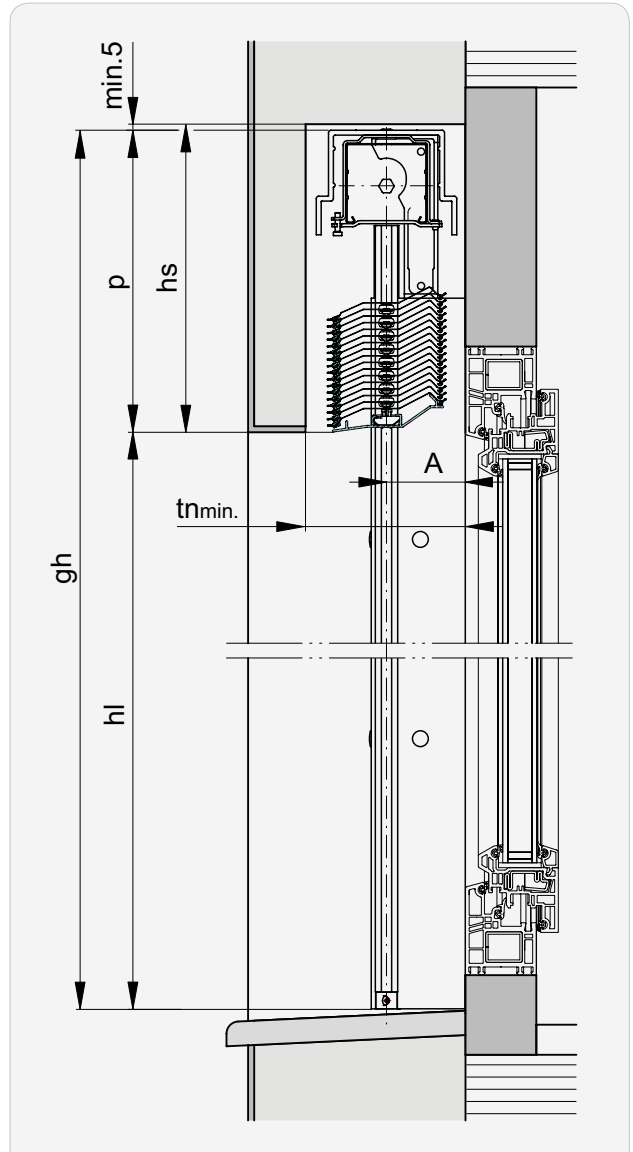

Horizontal section: Lamisol® III 70 System Profil

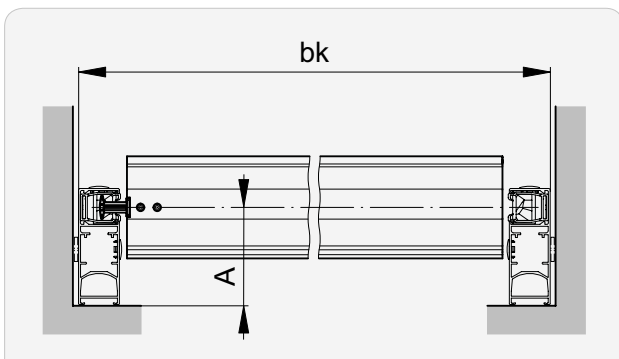

Horizontal section: Lamisol® III 90 System Profil

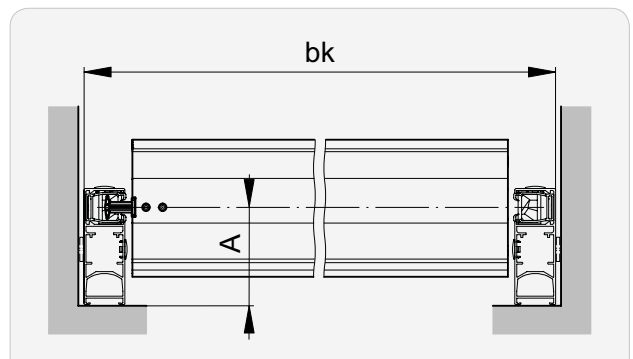

Installation system with Box

Horizontal section: Lamisol® III 70 System Box

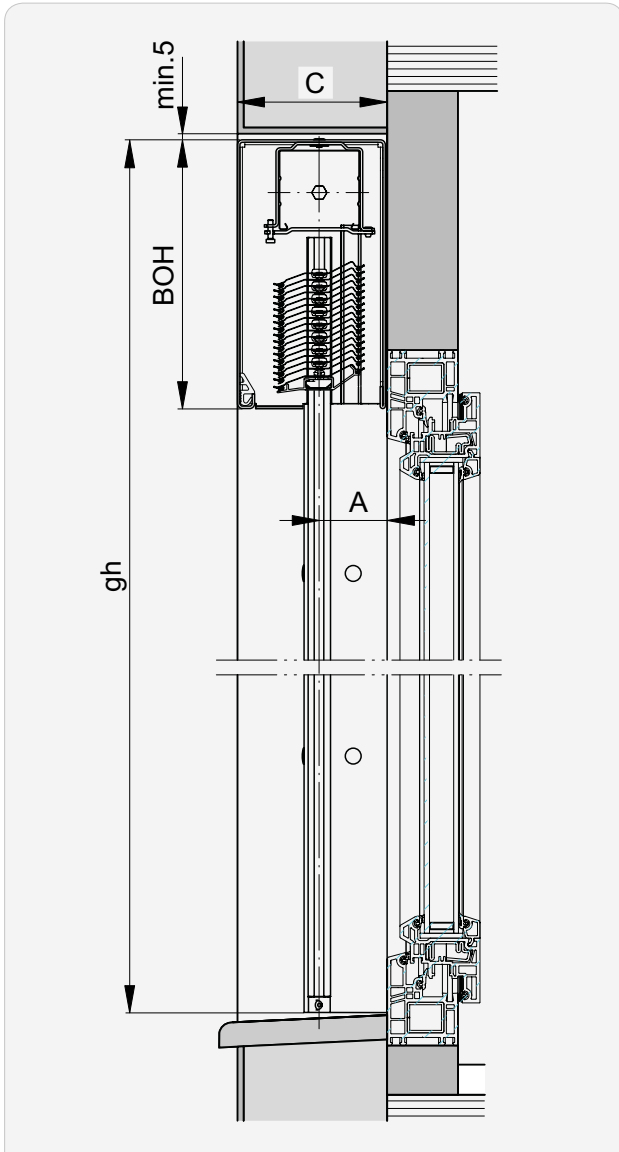

Box with slat package covered

Vertical section: Lamisol® III 90 System Box

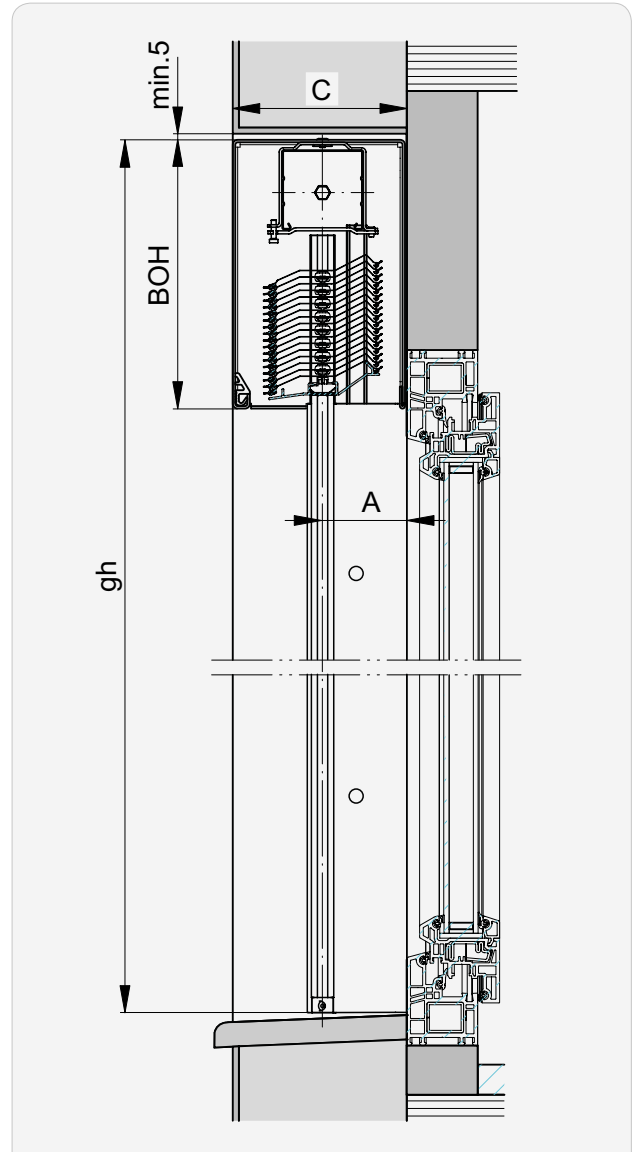

Box with slat package covered

Vertical section: Lamisol® III 70 System Box

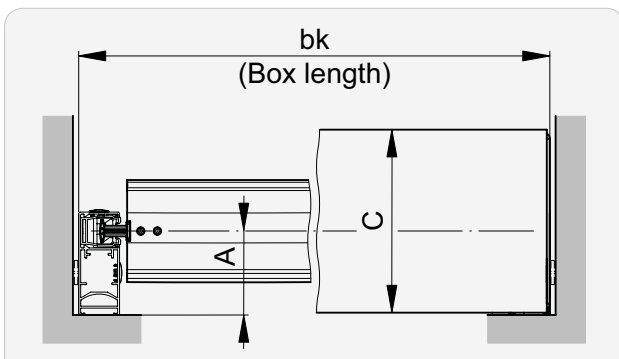

Horizontal section: Lamisol® III 90 System Box

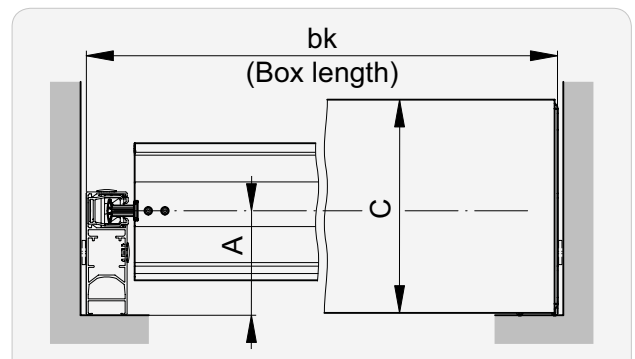

Header dimensions | Heights of package

Lamisol® III 70 System Profil

hl →l	P min.	hs	hl →l	P min.	hs
1750	230	235	3250	330	335
2000	245	250	3500	345	350
2250	260	265	3750	360	365
2500	280	285	4000	380	385
2750	295	300	4250	395	400
3000	310	315	4300	415	420

tn min.	A
130*	64.5

Lamisol® III 90 System Profil

hl →l	P min.	hs	hl →l	P min.	hs
1750	220	225	3250	300	305
2000	230	235	3500	315	320
2250	240	250	3750	325	330
2500	255	260	4000	345	350
2750	270	275	4250	355	360
3000	285	290	4300	370	375

tn min.	A
130*	64.5

Lamisol® III 70 System Box

gh →l	P	BOH	C	A
1440	188	190		
1920	218	220		
2510	258	260	121	55.5
3200	298	300		
4700		300 ¹		

Lamisol® III 90 System Box

gh →l	P	BOH	C	A
2120	218	220		
2860	258	260	141	69
3650	298	300		
4660		300 ¹		

¹ Slat package not covered (package projection)

* + possible addition for protruding weatherboard or doorknobs.

i Header dimensions are approximate values which may exhibit **negative or positive deviations** depending on the technical circumstances. **A dimensional tolerance of ±5 mm** is observed for the header height.

Slat profiles

Lamisol® III 70 System

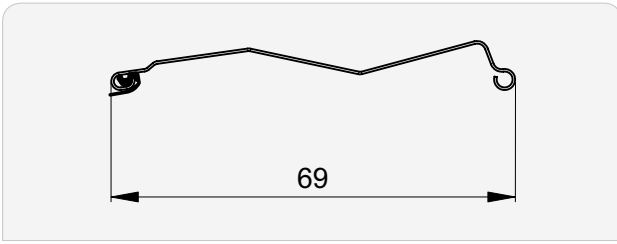

Lamisol® III 90 System

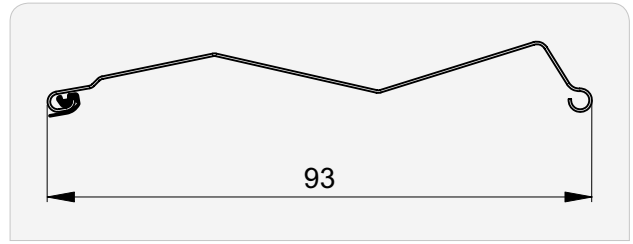

End rails

Lamisol® III 70 System

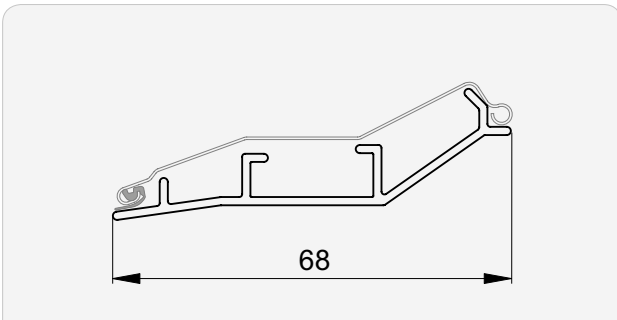

Lamisol® III 90 System

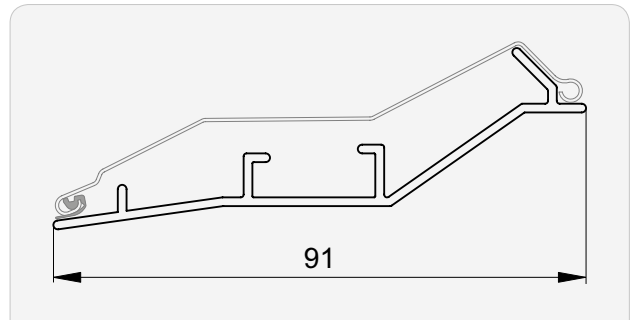

Beginning distance | Slot spacing

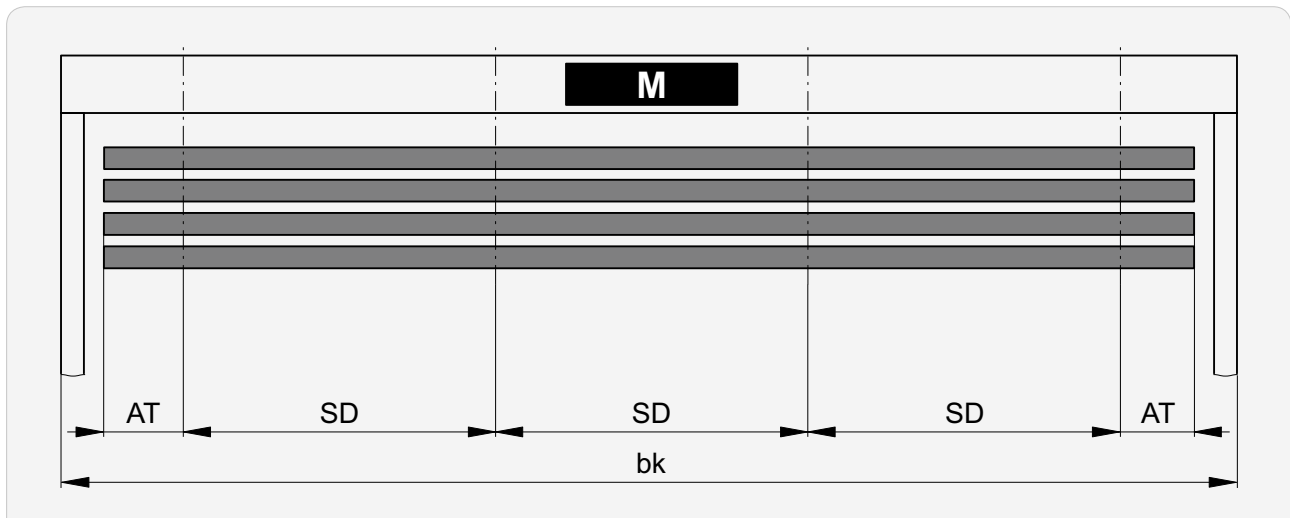

bk	AT min.	SD min.	SD max.
≤610	50		
611...1250	100	350*	1000*
>1250	200		
Special	250		

* Standard slot spacing machine fabrication

Deviations from the standard are possible when:

Deviation	Correction
Support loading too high	AS
Slot spacing < 350	AT + AS
With motor	AT + AS

AT Beginning distance
Distance from beginning of slat to centre of bearing

SD Slot spacing
Distance from centre of bearing (slot) to centre of bearing (slot)

Orientation of cable outlet

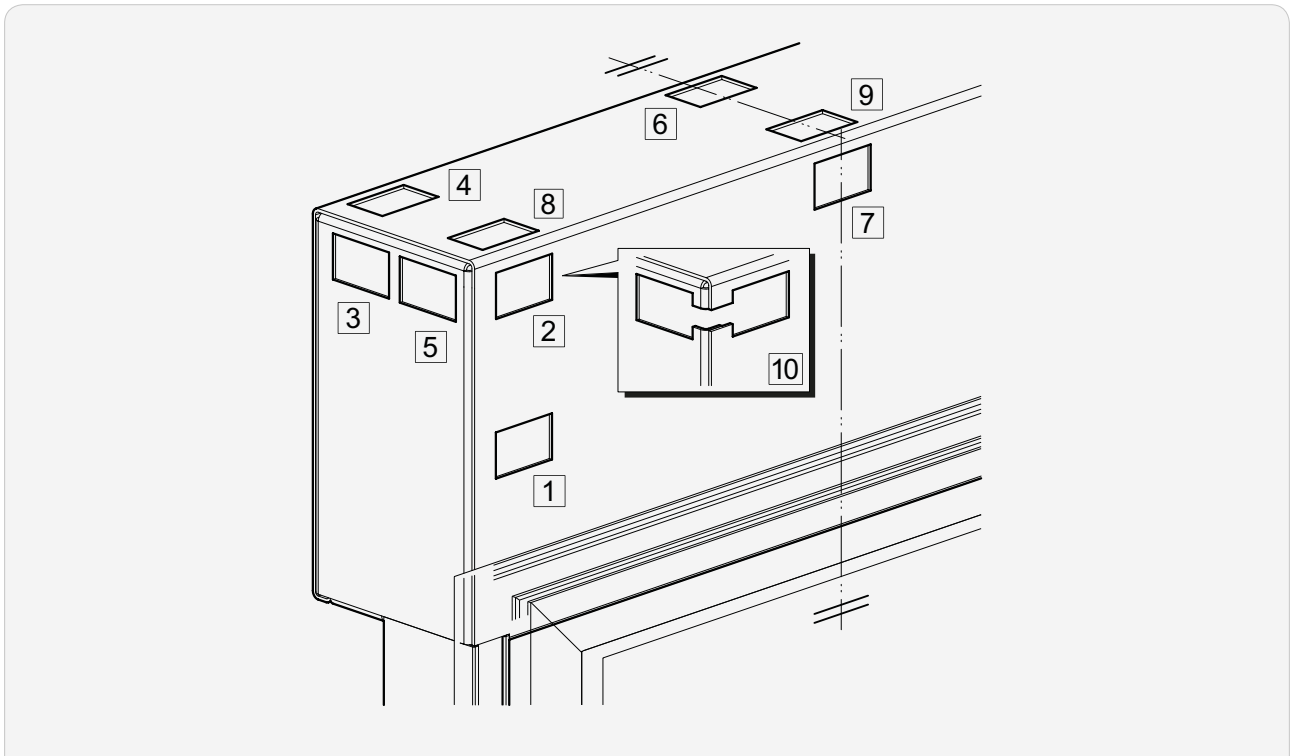

Lamisol® III 70 System

Position	Cable outlet									
	1	2	3	4	5	6	7	8	9	10
left	01L	02L*	03L	04L	05L	–	–	08L*	–	10L
centre	–	–	–	–	–	06M	07M*	–	09M*	–
right	01R	02R*	03R	04R	05R	–	–	08R*	–	10R

Lamisol® III 90 System

Position	Cable outlet									
	1	2	3	4	5	6	7	8	9	10
left	01L	02L*	03L	04L	05L	–	–	08L	–	10L
centre	–	–	–	–	–	06M	07M*	–	09M	–
right	01R	02R*	03R	04R	05R	–	–	08R	–	10R

! *The plug cannot be passed through when assembled!

Guide rails

Type P | Lamisol® III System Profil

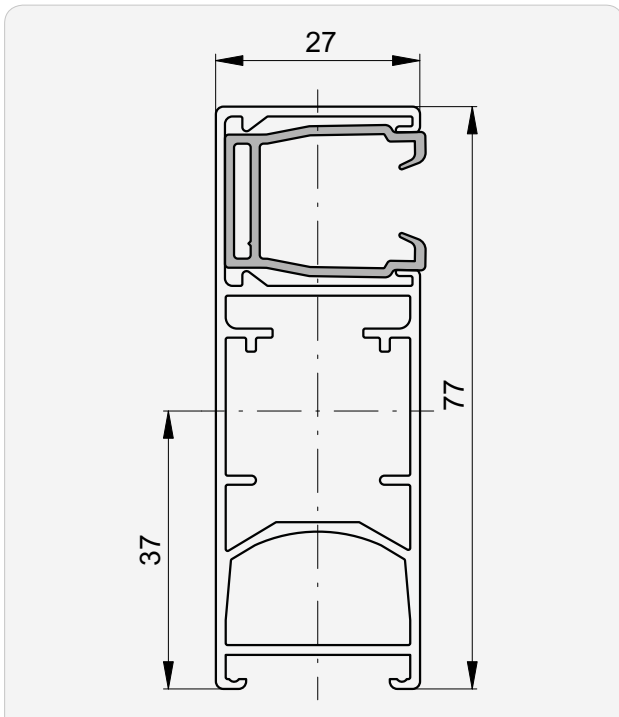

Type K | Lamisol® III 70 System Box

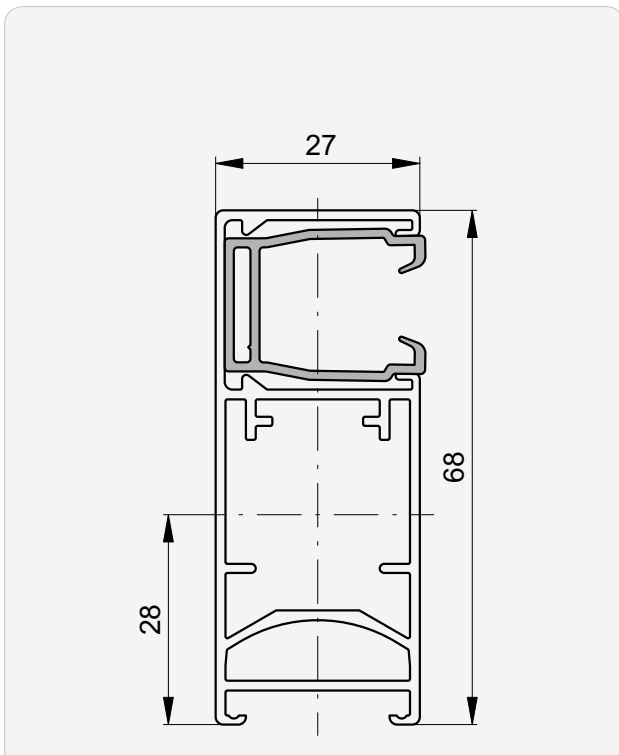

Type B | Lamisol® III 90 System Box

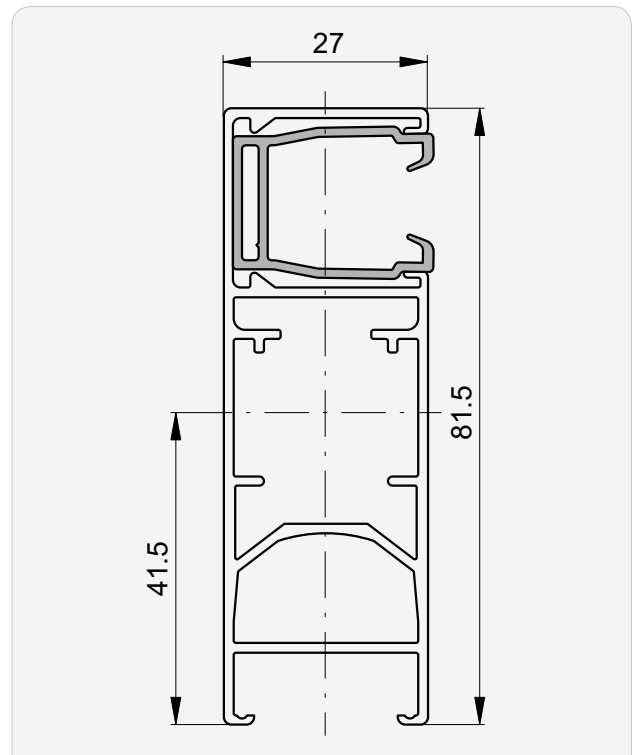

➤ Fastening points	141 145
➤ Guide extension and facet	139

➤ Guide rail fastenings	138
-------------------------------	-----

Sections | Details

Horizontal section: Lamisol® III 70 System Profil

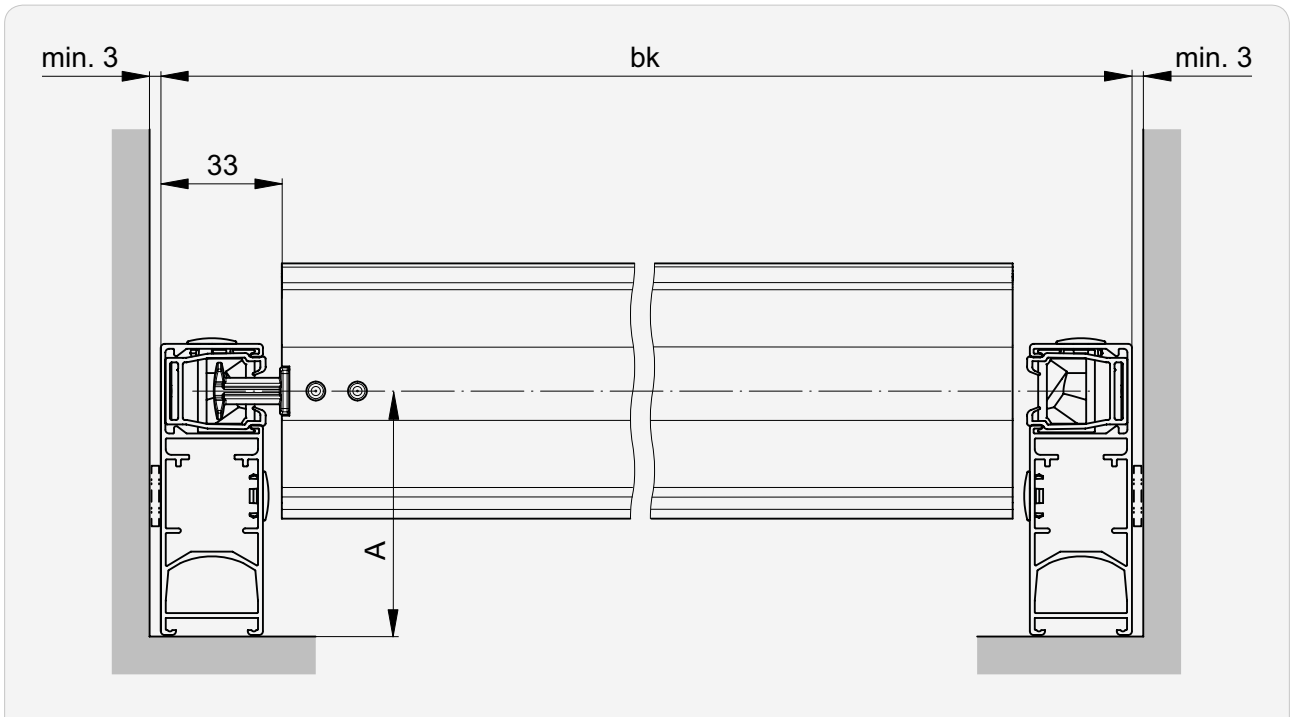

Horizontal section: Lamisol® III 90 System Profil

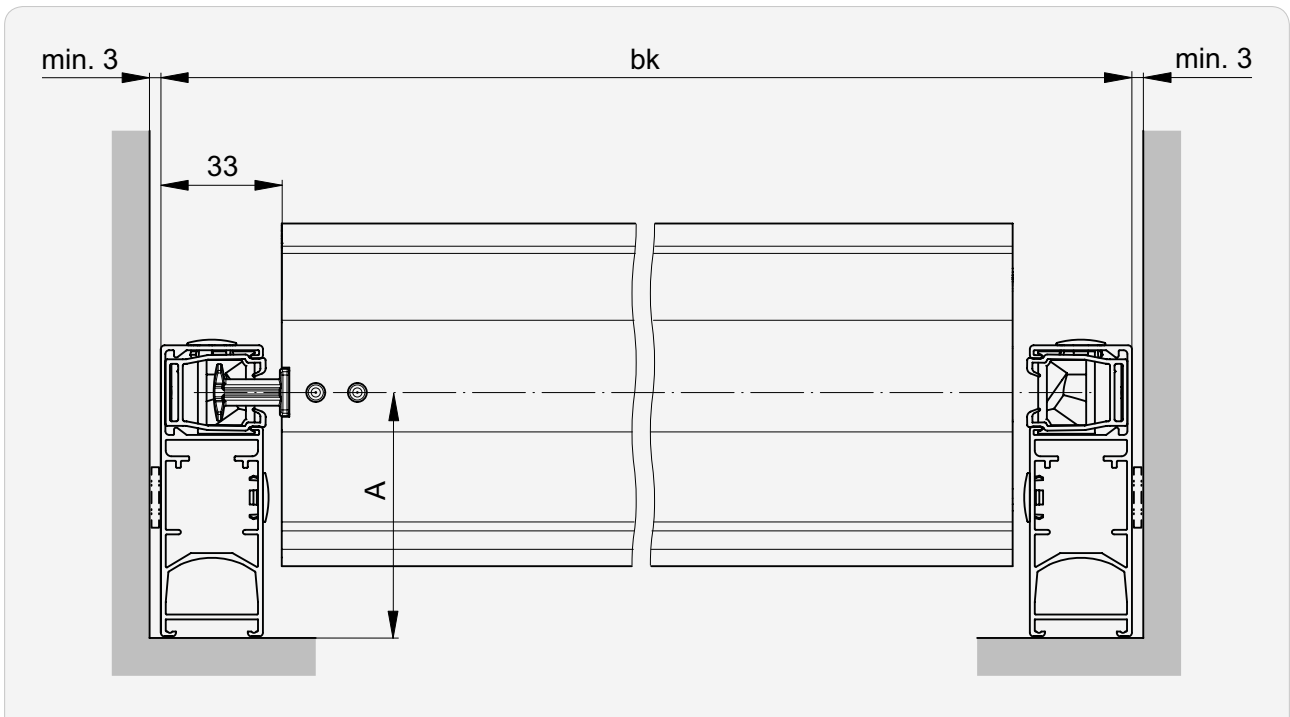

➡ Value for A 125

►► Sections | Details

Horizontal section: Lamisol® III 70 System Box

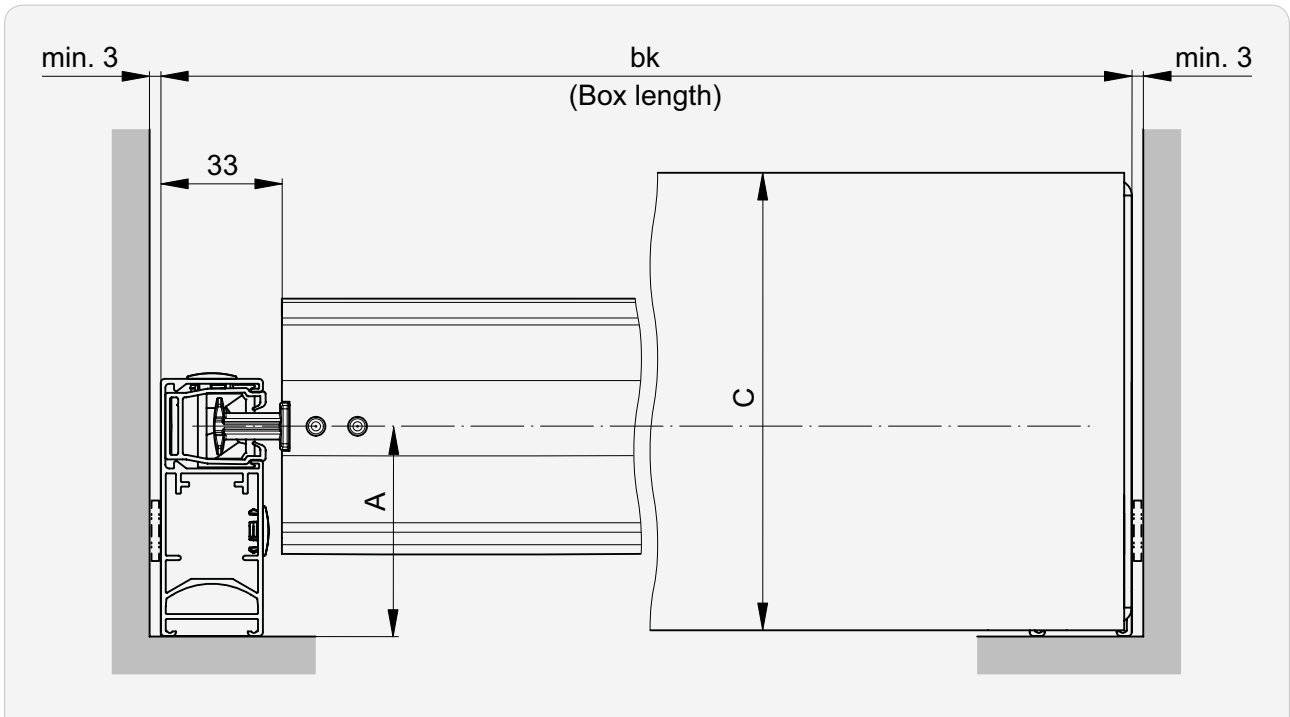

Horizontal section: Lamisol® III 90 System Box

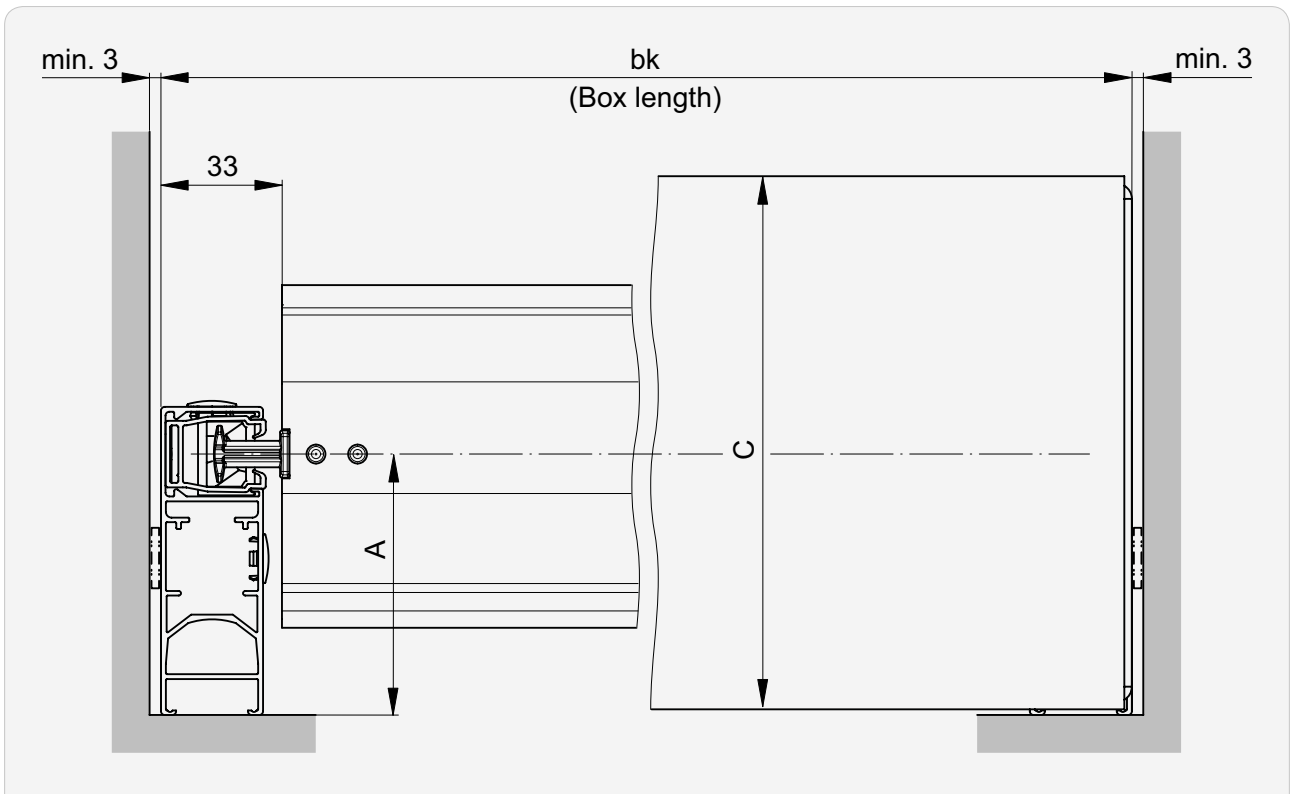

➔ Values for **A** and **C** 125

Vertical connections | Standard motor position

Number of bearings

Lamisol® III 70 System

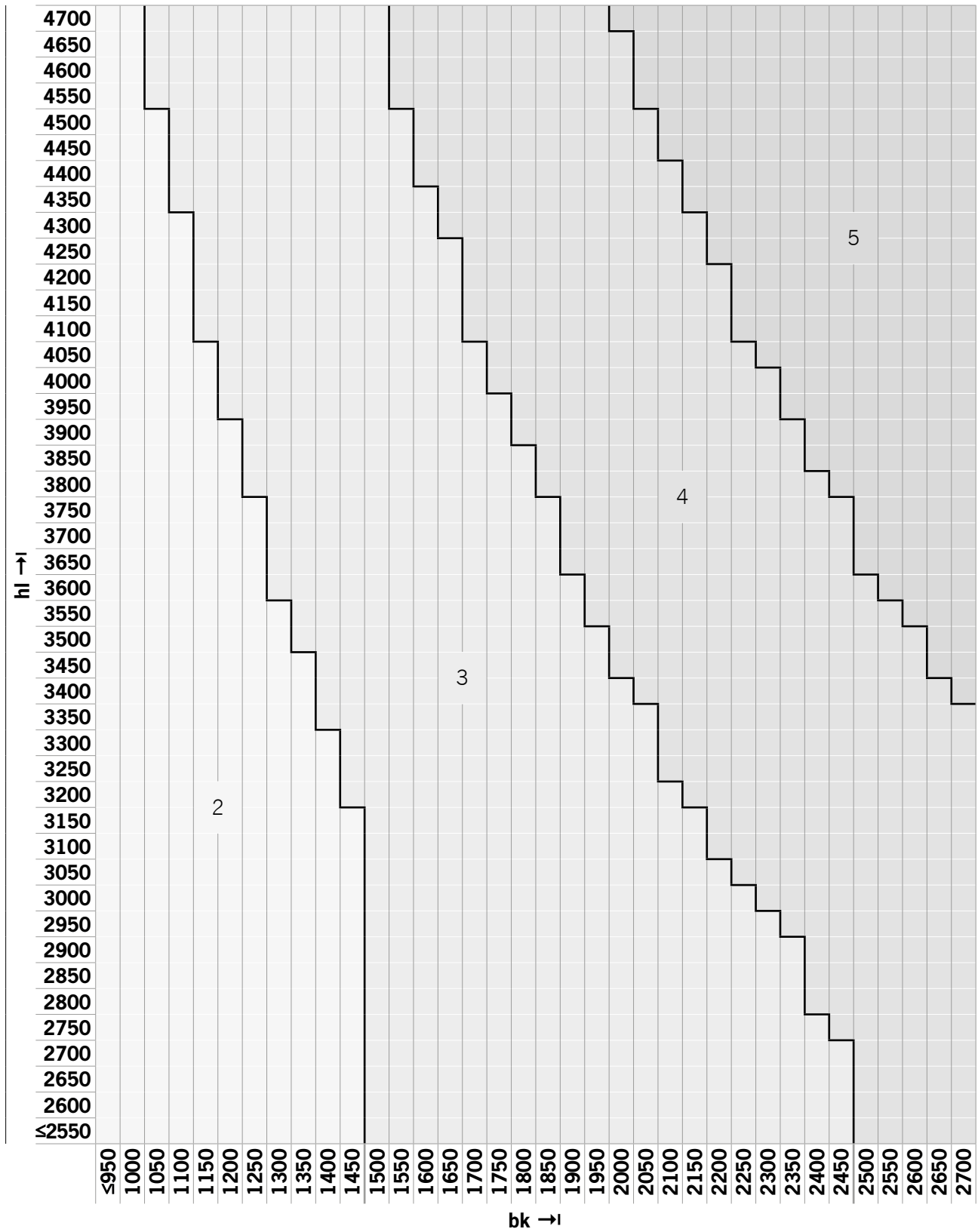

►► Vertical connections | Standard motor position

Number of bearings

Lamisol® III 70 System

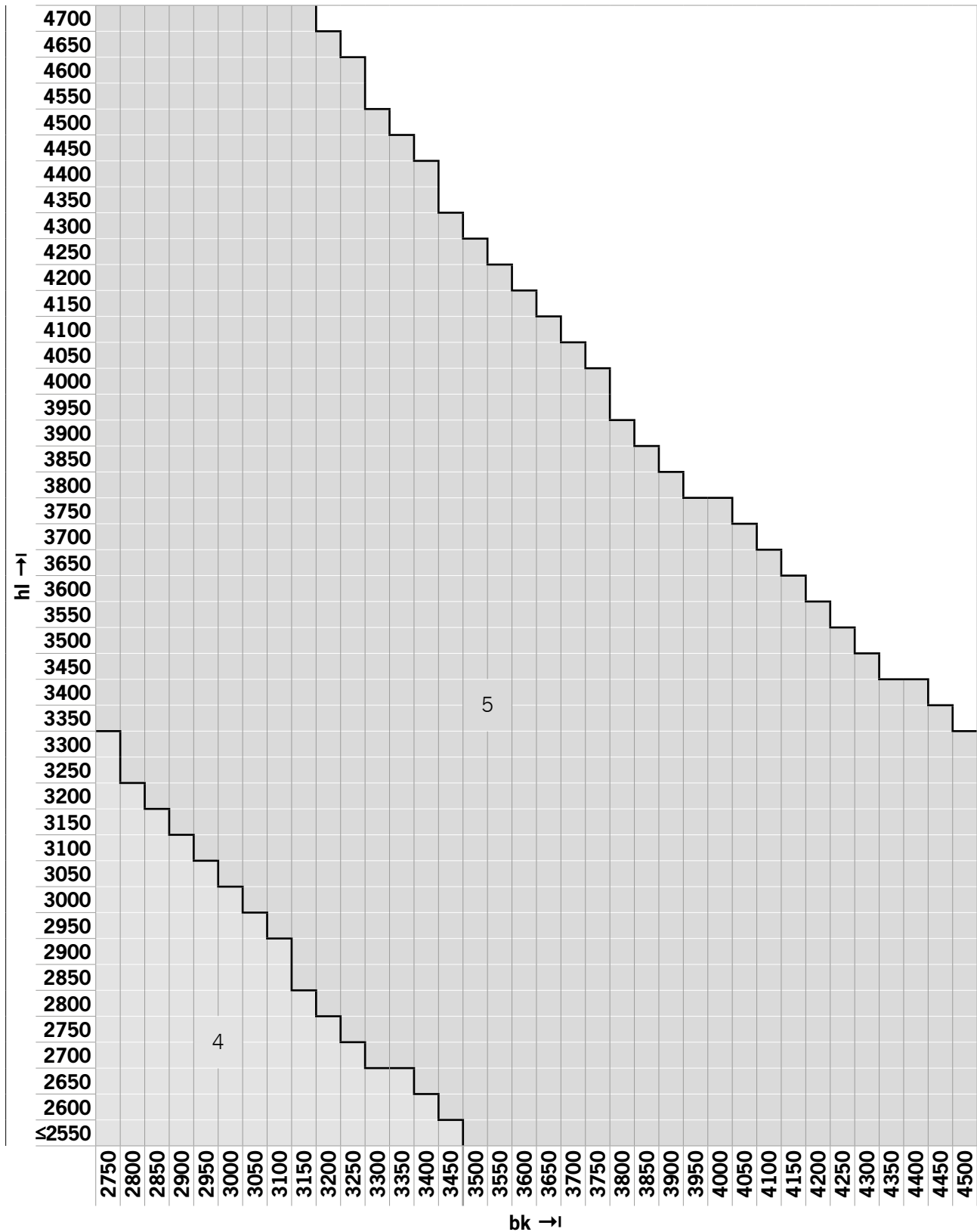

►► Vertical connections | Standard motor position

Number of bearings

Lamisol® III 90 System

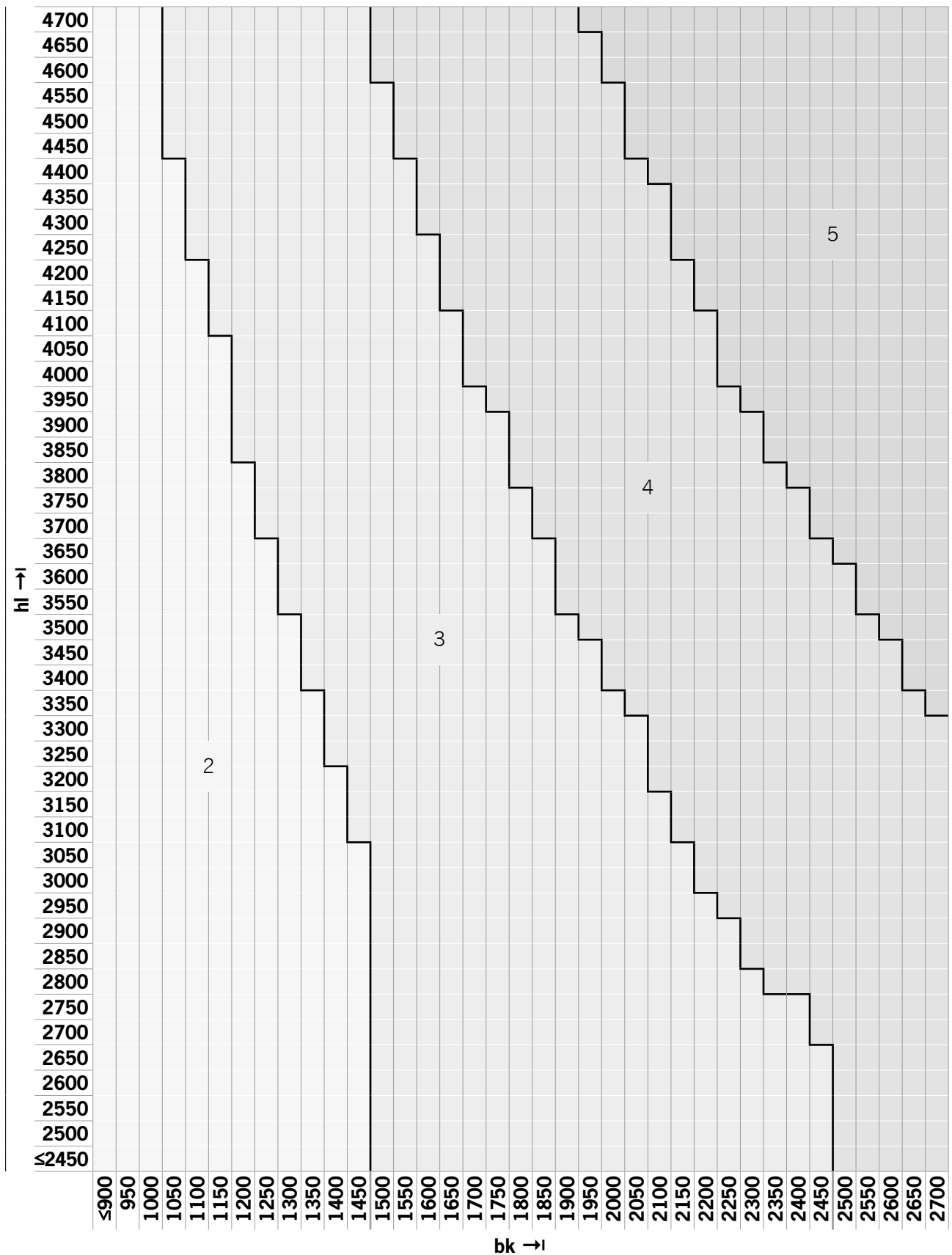

► Standard motor position 136

►► Vertical connections | Standard motor position



Number of bearings

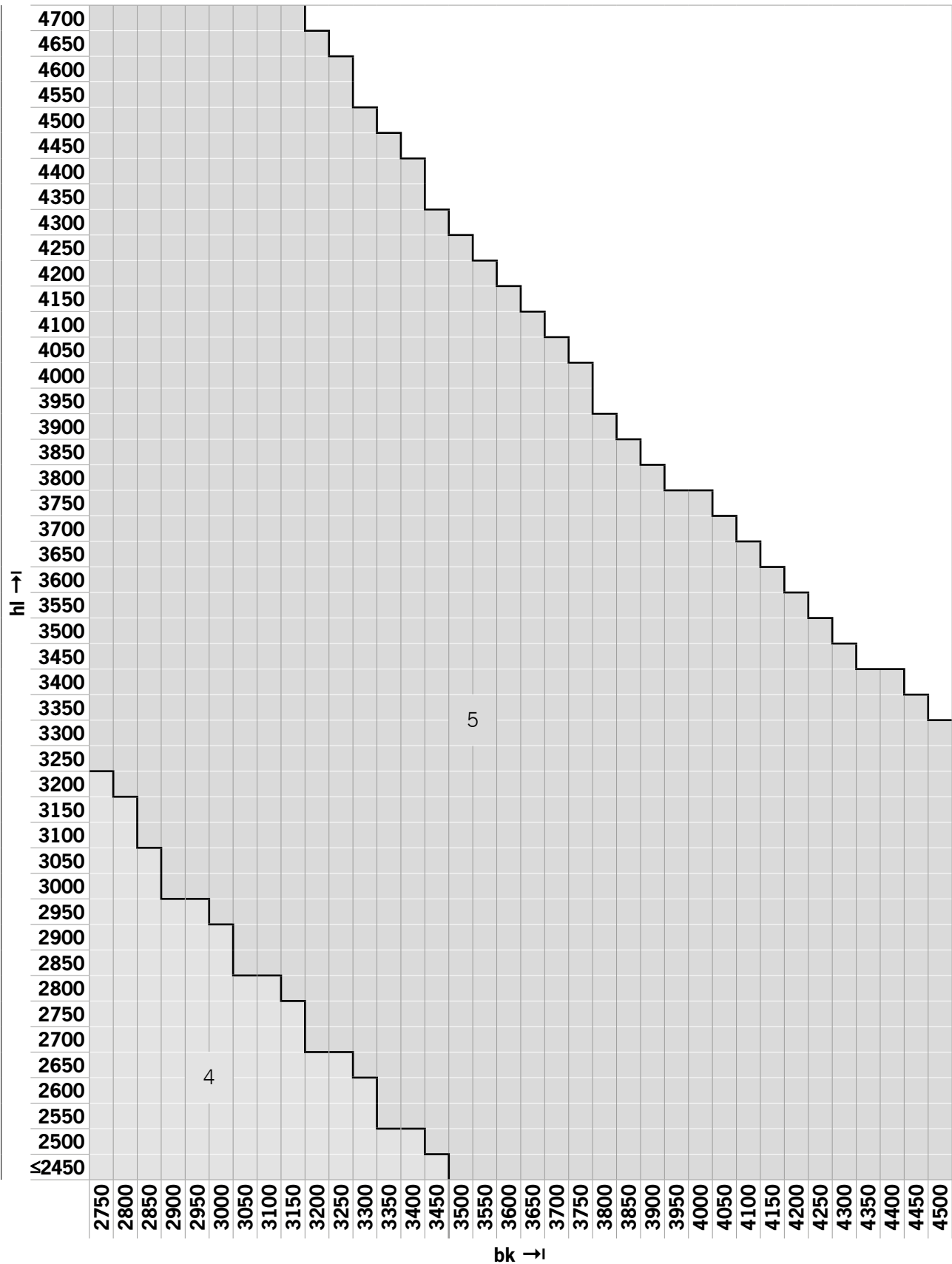

Lamisol® III 90 System

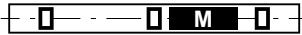

▶▶ Vertical connections | Standard motor position

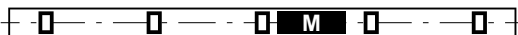
Standard motor position

Number of bearings	Standard motor position
2	
3	
4	
5	

-  Bearing
-  Standard motor position

Guide rail installation (principle)

Guides attached (to soffit) | Type A

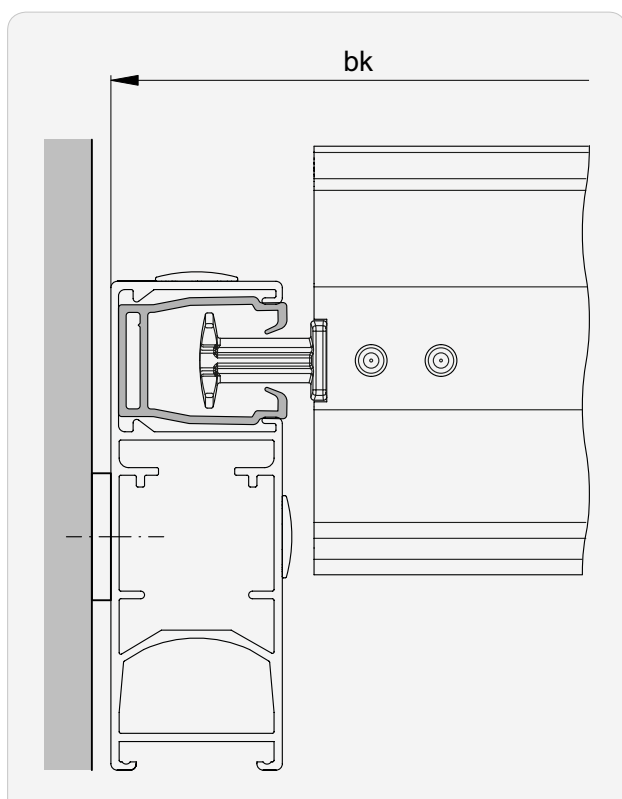

i Observe possible guide rail spacer for **bk**.
Standard: 3 mm

Guide rail fastenings (principle)

Overview

														Type
A	B	Bd	C	Cd	E	F	G	H	Kv	M	T	Tv	V	Wv
●	-	-	-	-	-	-	●	-	-	-	-	-	-	-

- applicable without restrictions

A Soffit installation

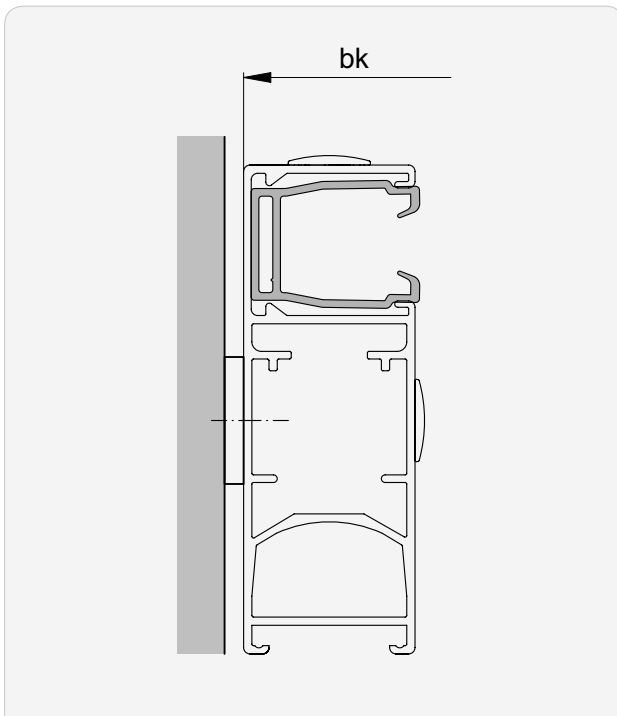

G Facade installation

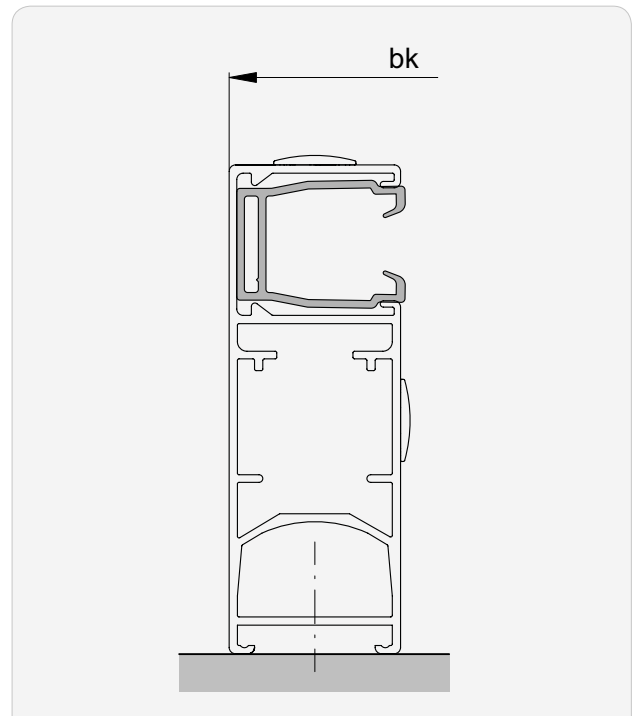

i Observe possible guide rail spacer for **bk**.
Standard: 3 mm

Guide extension and facet

Extension

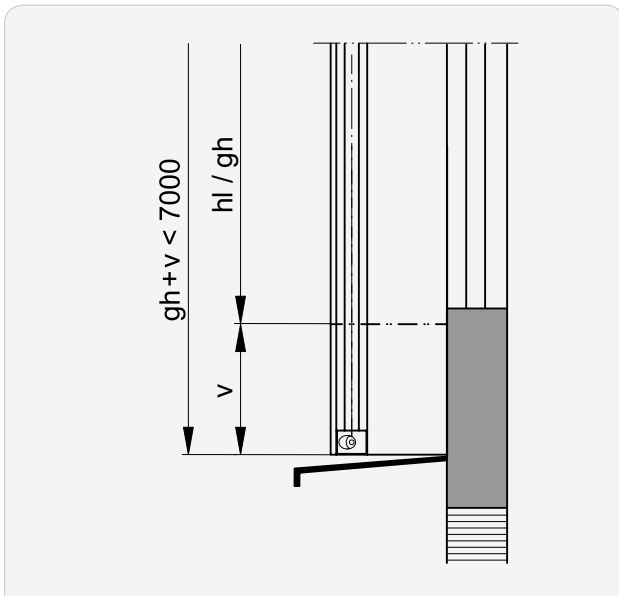

v
-20... 1000

Facet

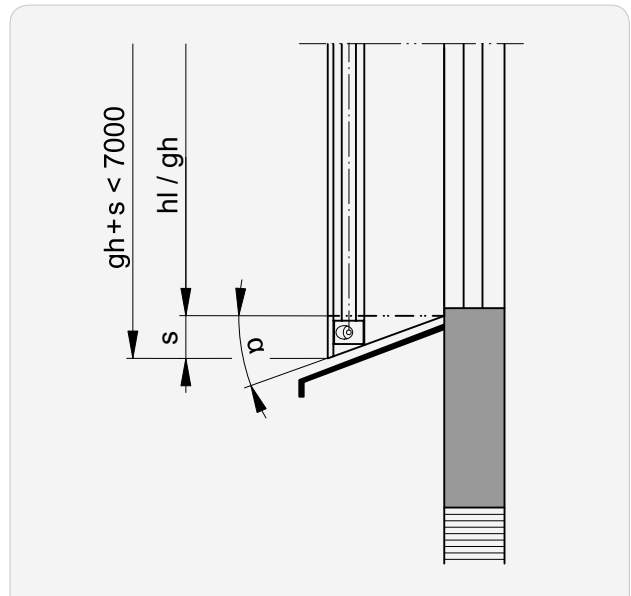

α
5... 50°

Extension and facet

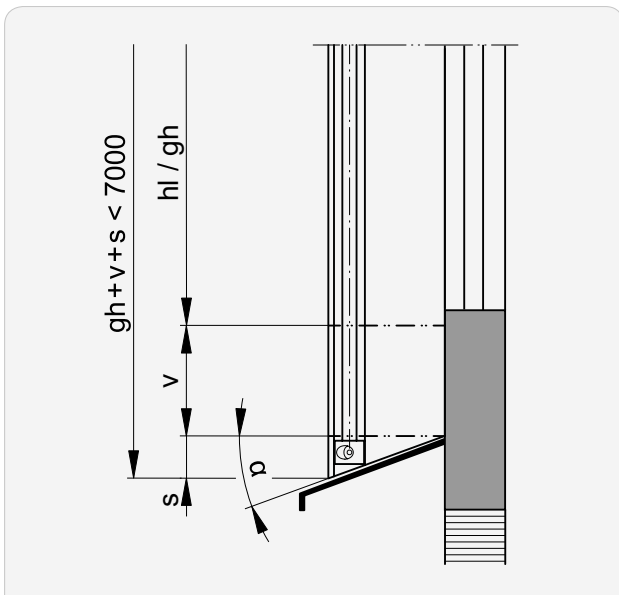

v
0... 1000

α
5... 50°

➔ Value for **s**..... 140

Angling at the guides

Type P | Lamisol® III System Profil

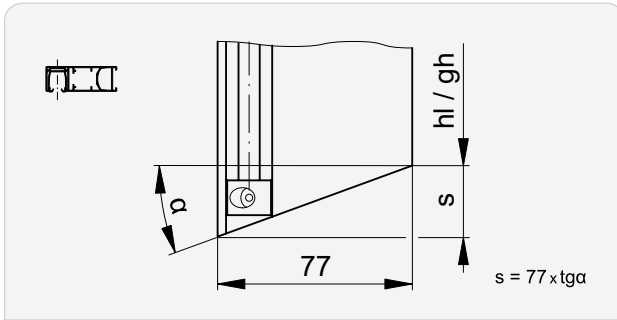

α	s	α	s	α	s	α	s	α	s
5	7	15	21	25	36	35	54	45	77
6	8	16	22	26	38	36	56	46	80
7	9	17	24	27	39	37	58	47	83
8	11	18	25	28	41	38	60	48	86
9	12	19	27	29	43	39	62	49	89
10	14	20	28	30	44	40	65	50	92
11	15	21	30	31	46	41	67		
12	16	22	31	32	48	42	69		
13	18	23	33	33	50	43	72		
14	19	24	34	34	52	44	74		

Type K | Lamisol® III 70 System Box

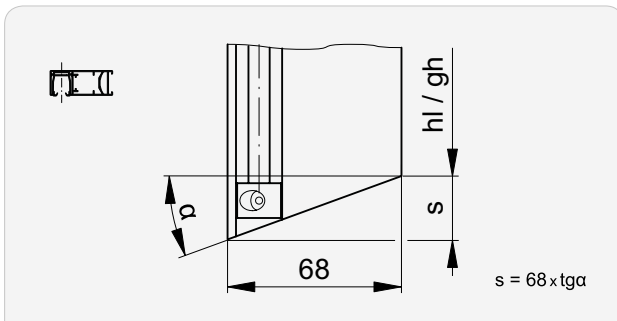

α	s	α	s	α	s	α	s	α	s
5	6	15	18	25	32	35	48	45	68
6	7	16	19	26	33	36	49	46	70
7	8	17	21	27	35	37	51	47	73
8	10	18	22	28	36	38	53	48	76
9	11	19	23	29	38	39	55	49	78
10	12	20	25	30	39	40	57	50	81
11	13	21	26	31	41	41	59		
12	14	22	27	32	42	42	61		
13	16	23	29	33	44	43	63		
14	17	24	30	34	46	44	66		

Type B | Lamisol® III 90 System Box

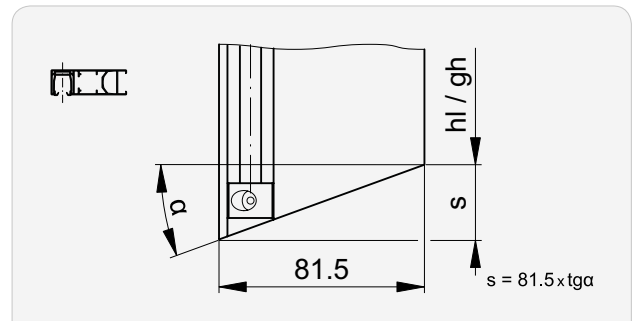

α	s	α	s	α	s	α	s	α	s
5	7	15	22	25	38	35	57	45	82
6	9	16	23	26	40	36	59	46	84
7	10	17	25	27	42	37	61	47	87
8	11	18	26	28	43	38	64	48	91
9	13	19	28	29	45	39	66	49	94
10	14	20	30	30	47	40	68	50	97
11	16	21	31	31	49	41	71		
12	17	22	33	32	51	42	73		
13	19	23	35	33	53	43	76		
14	20	24	36	34	55	44	79		

Fastening points Lamisol® III System Profil

Without extension

Z	AS
≤ 1500	2
1501 ... 2700	3
2701 ... 3900	4
3901 ... 5100	5
> 5100	6

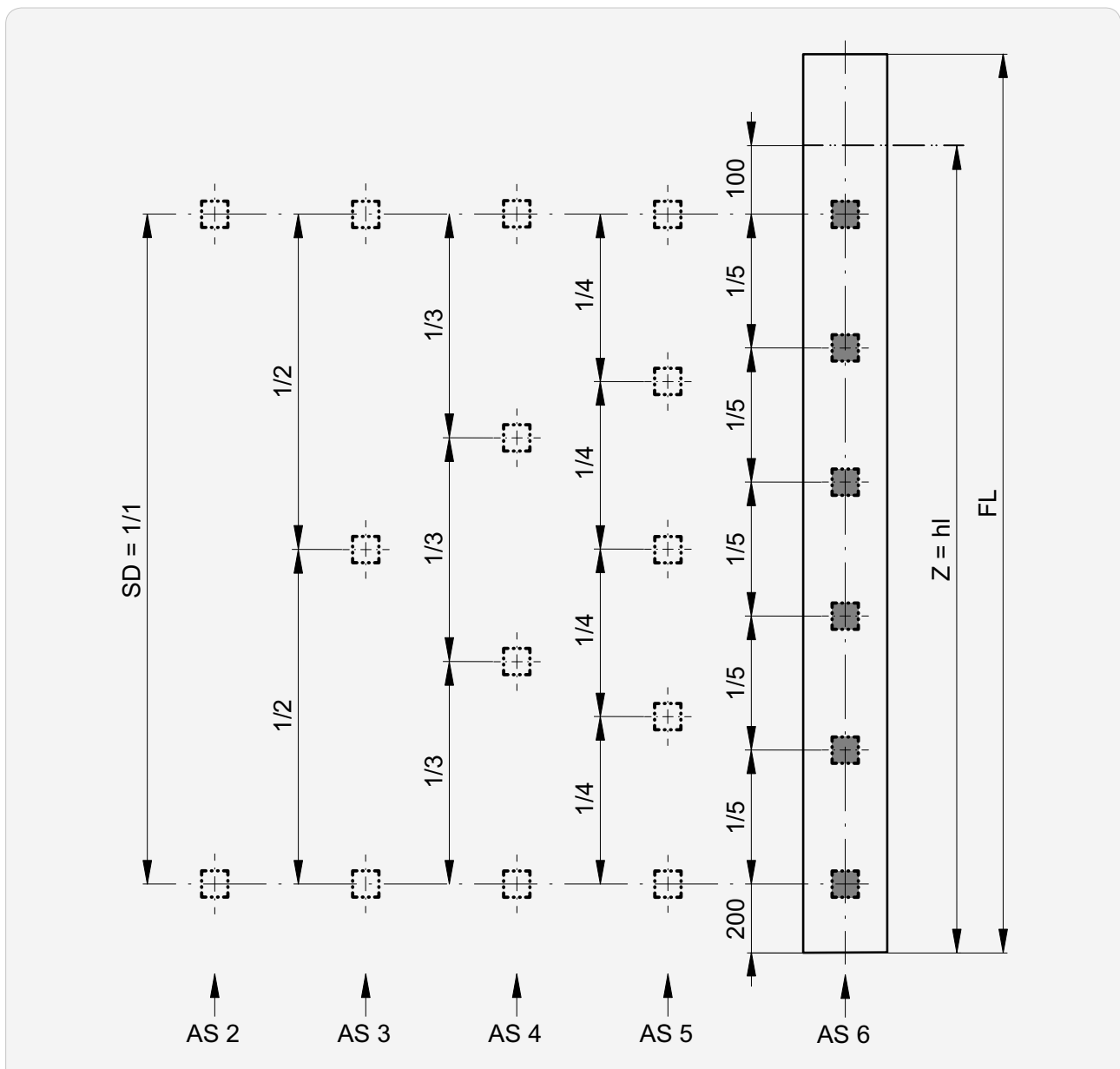

AS Number of slits

SD Slot spacing: max. 1200

[Guide rail fastenings](#) 138

►► Fastening points Lamisol® III System Profil

With guide rail extension

Z	AS
≤ 1500	2
1501 ... 2700	3
2701 ... 3900	4
3901 ... 5100	5
> 5100	6

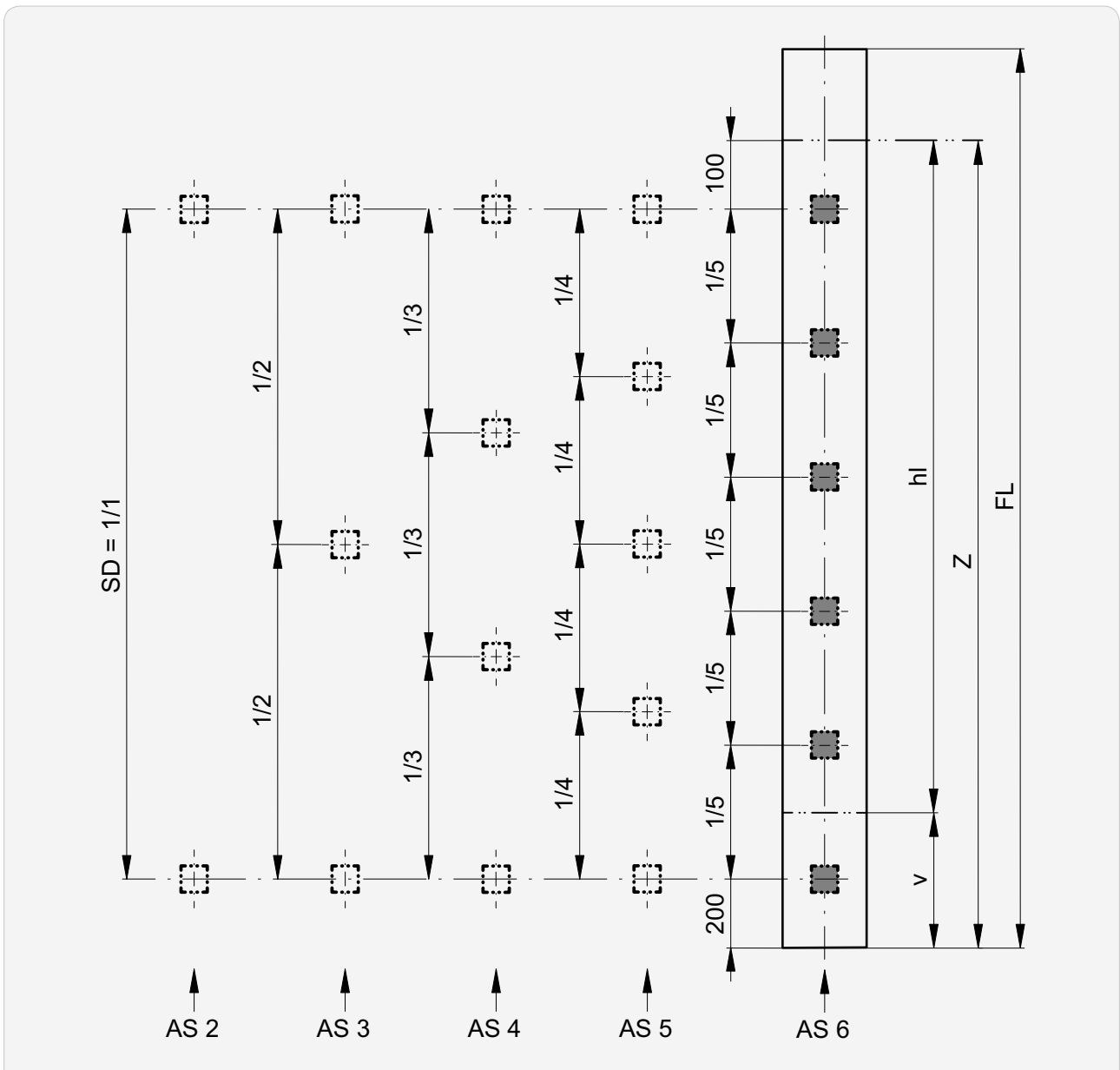

AS Number of slits
SD Slot spacing: max. 1200

v Guide rail extension: max. 1000

►► Fastening points Lamisol® III System Profil

With facet

Z	AS
≤ 1500	2
1501 ... 2700	3
2701 ... 3900	4
3901 ... 5100	5
> 5100	6

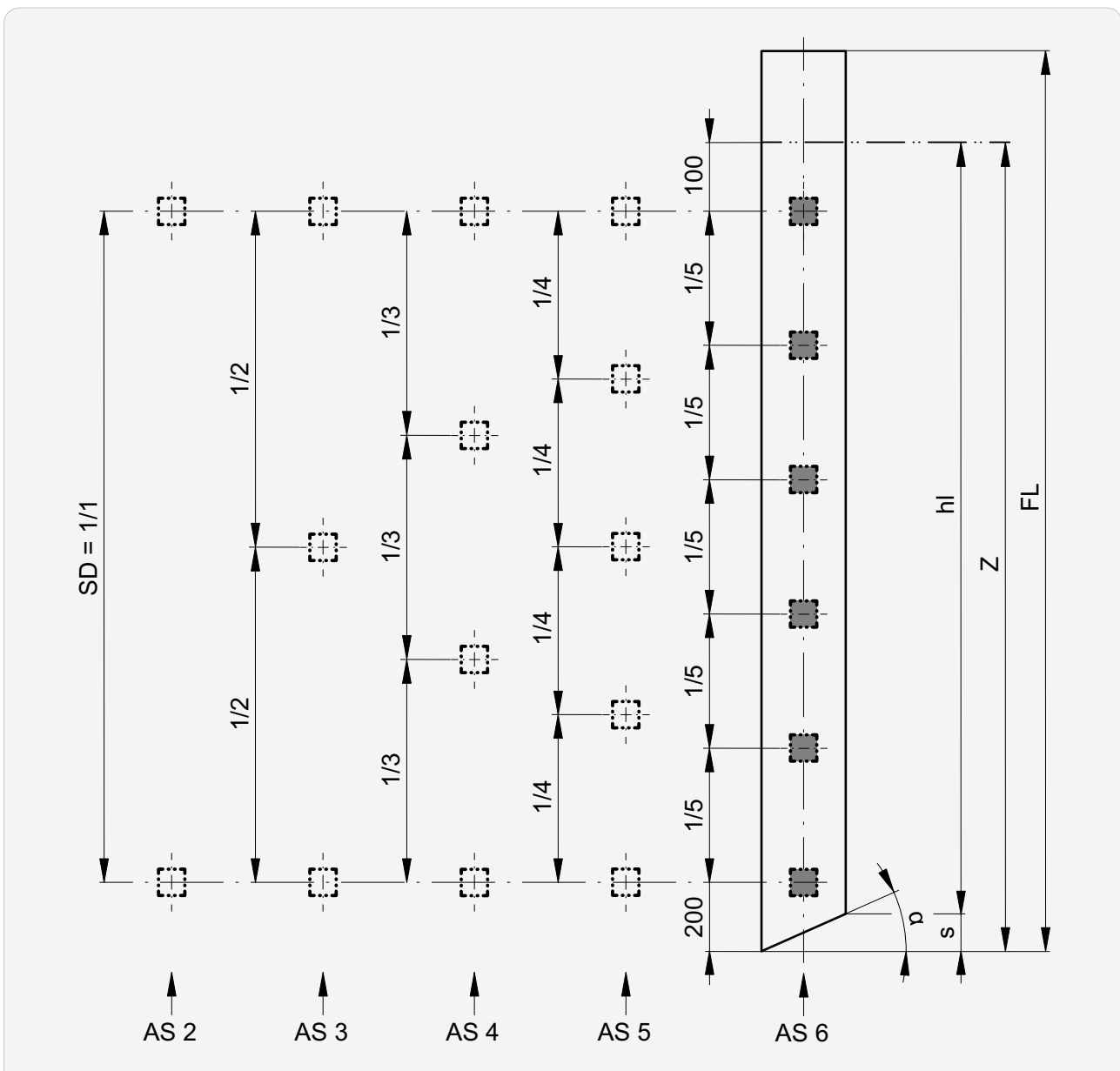

AS Number of slits

SD Slot spacing: max. 1200

s Faceting (guide rail width x $\tan \alpha$)

►► Fastening points Lamisol® III System Profil

With guide rail extension and facet

Z	AS
≤ 1500	2
1501 ... 2700	3
2701 ... 3900	4 </td
3901 ... 5100	5
> 5100	6

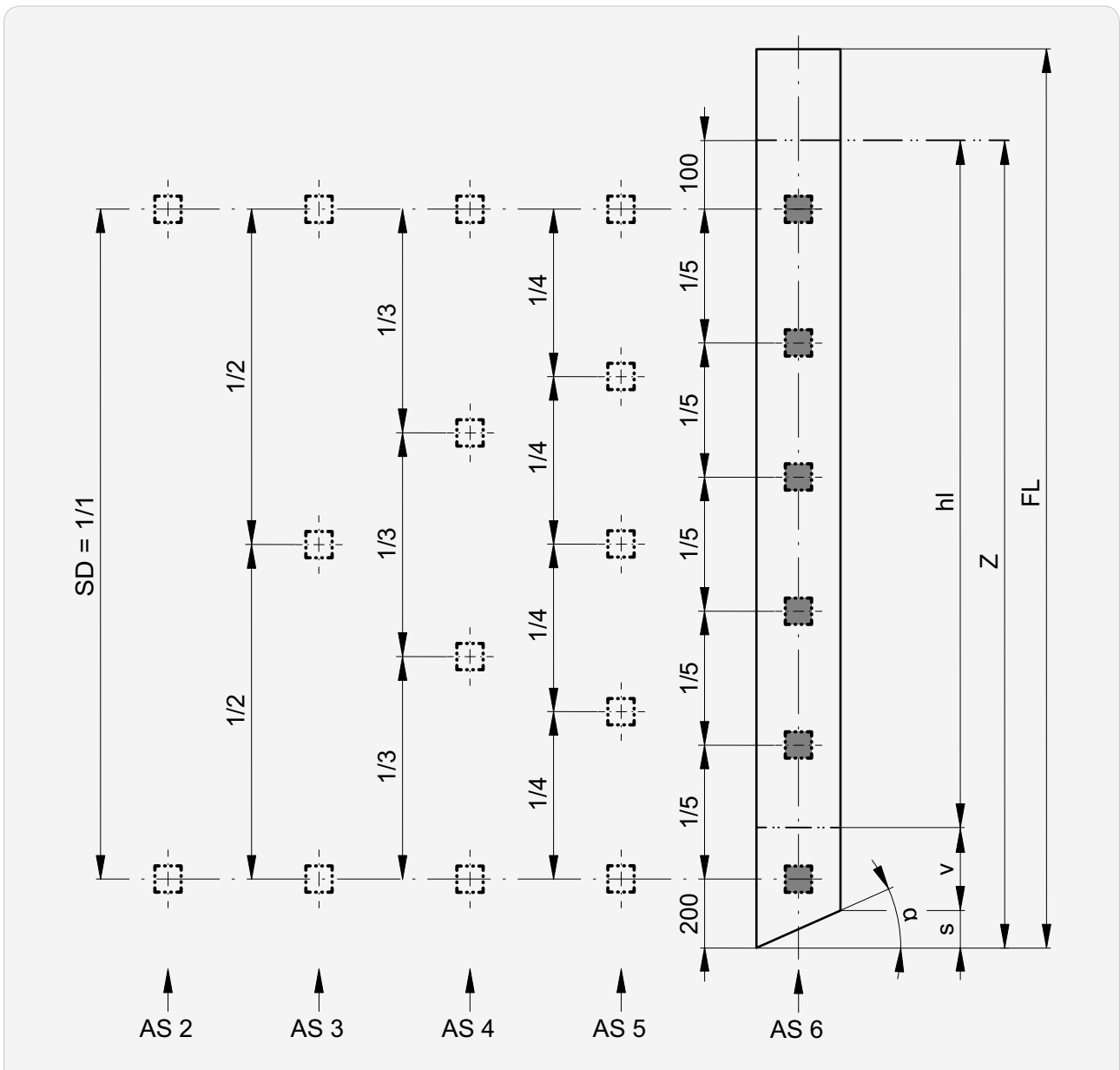

AS Number of slits

s Faceting (guide rail width x tgα)

SD Slot spacing: max. 1200

v Guide rail extension: max. 1000

Fastening points Lamisol® III System Box

Without extension

Z	AS
≤ 1450	2
1451 ... 2450	3
2451 ... 3450	4
> 3450	5

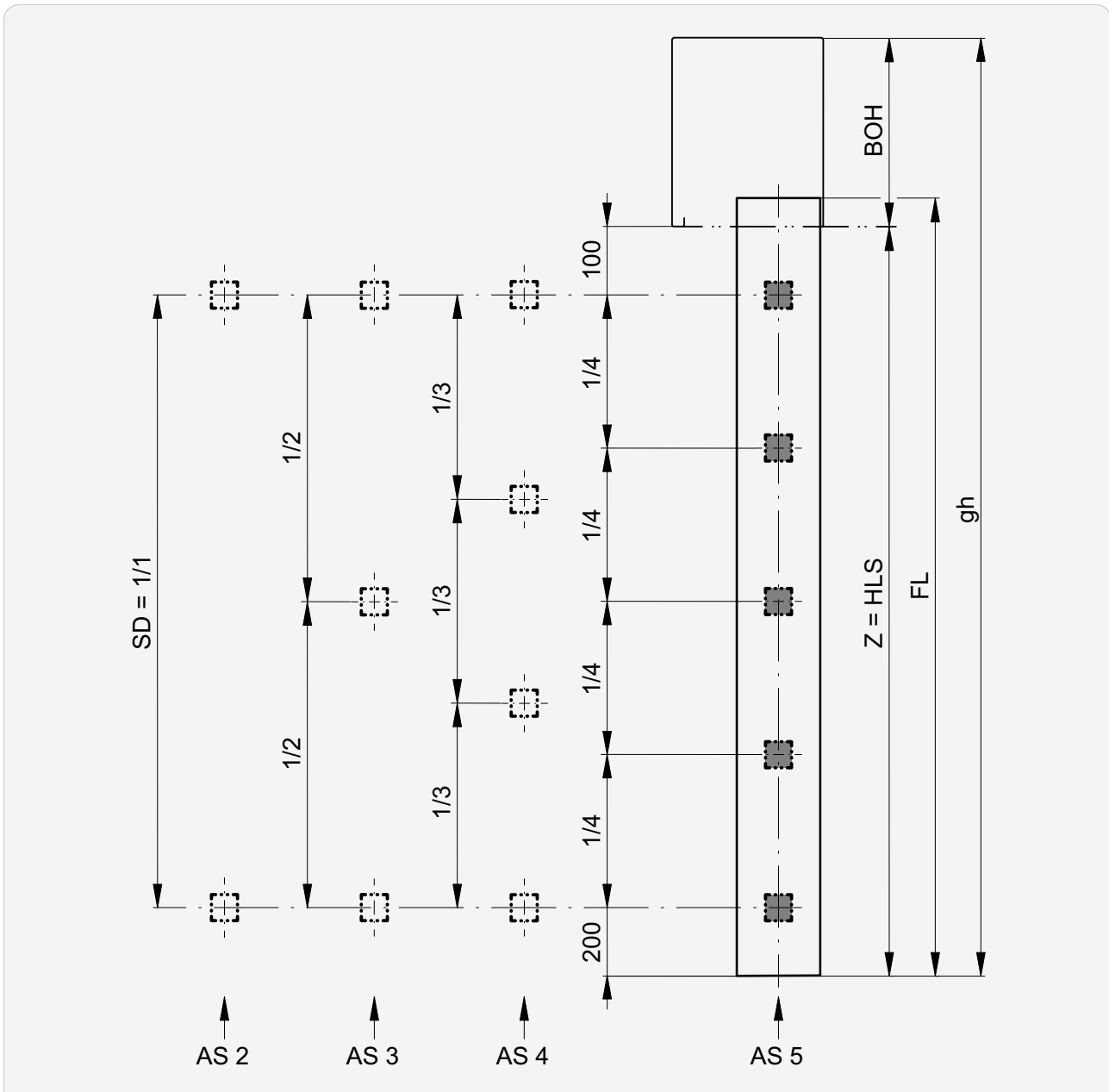

AS Number of slits

BOH Box height

SD Slot spacing: max. 1200

➔ Guide rail fastenings 138

►► Fastening points Lamisol® III System Box

With guide rail extension

Z	AS
≤ 1450	2
1451 ... 2450	3
2451 ... 3450	4
> 3450	5

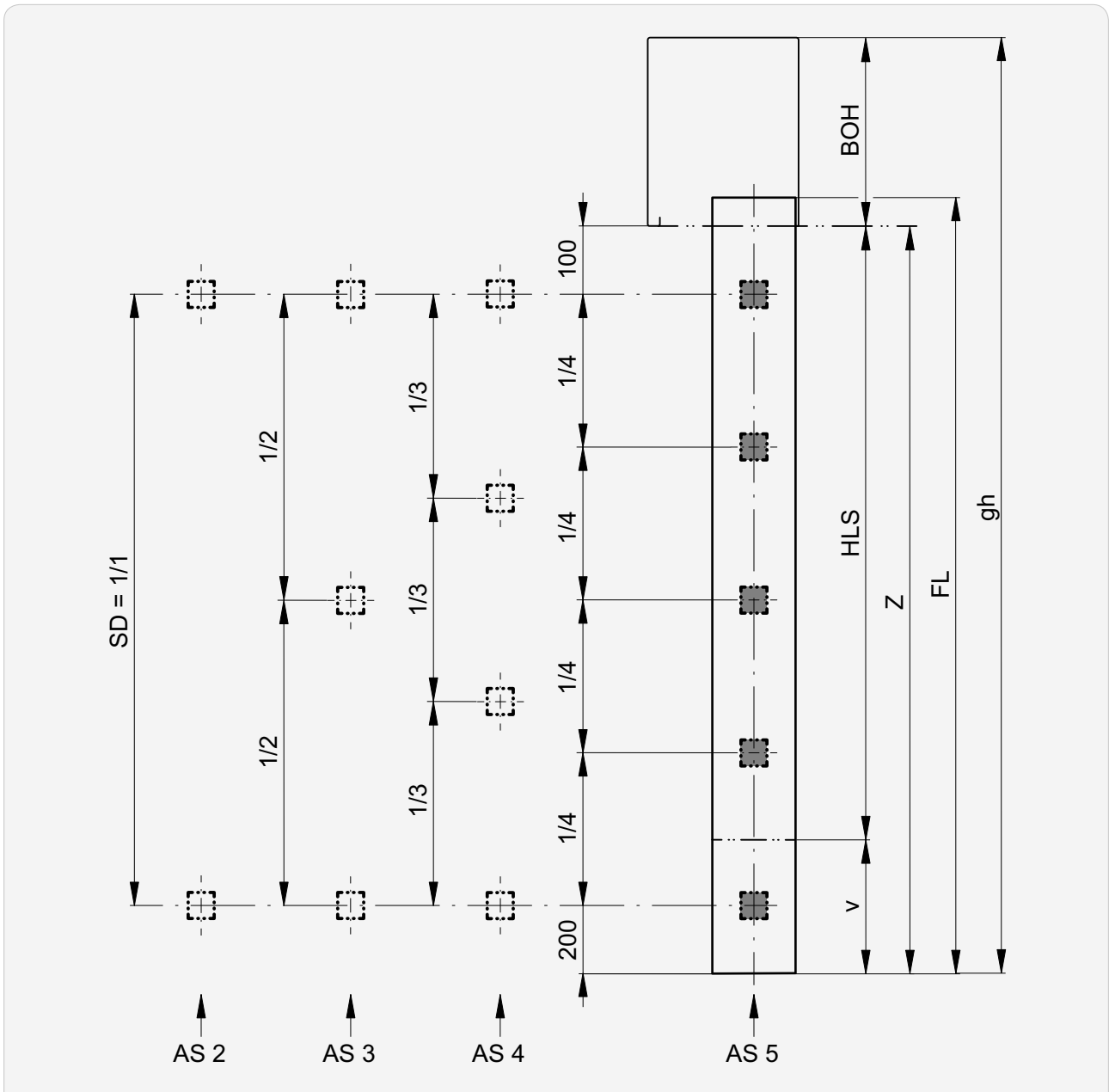

AS Number of slits

BOH Box height

SD Slot spacing: max. 1200

v Guide rail extension: max. 1000

►► Fastening points Lamisol® III System Box

With facet

Z	AS
≤ 1450	2
1451 ... 2450	3
2451 ... 3450	4
> 3450	5

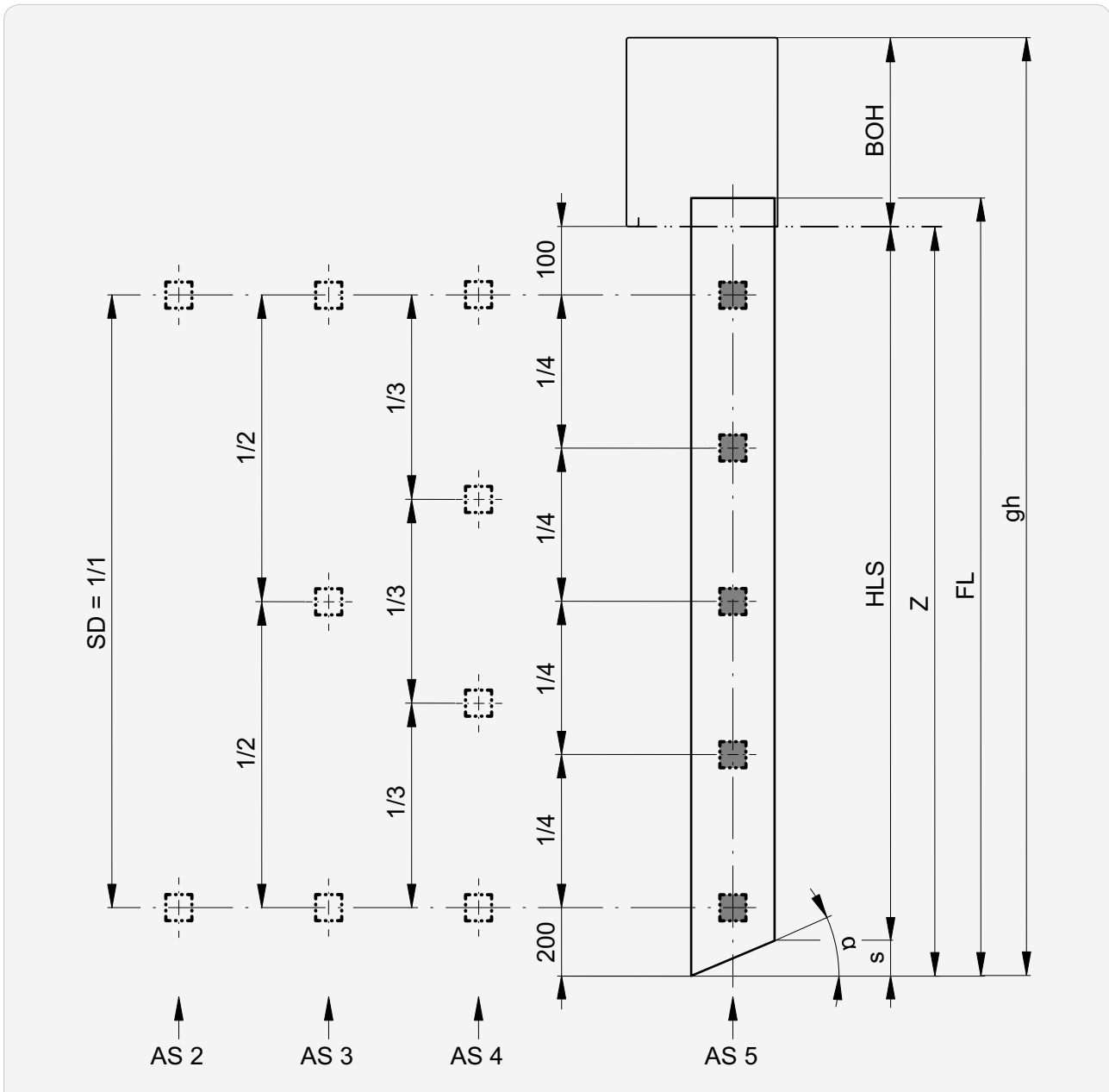

AS Number of slits

BOH Box height

s Faceting (guide rail width x tgα)

SD Slot spacing: max. 1200

►► Fastening points Lamisol® III System Box

With guide rail extension and facet

Z	AS
≤ 1450	2
1451 ... 2450	3
2451 ... 3450	4
> 3450	5

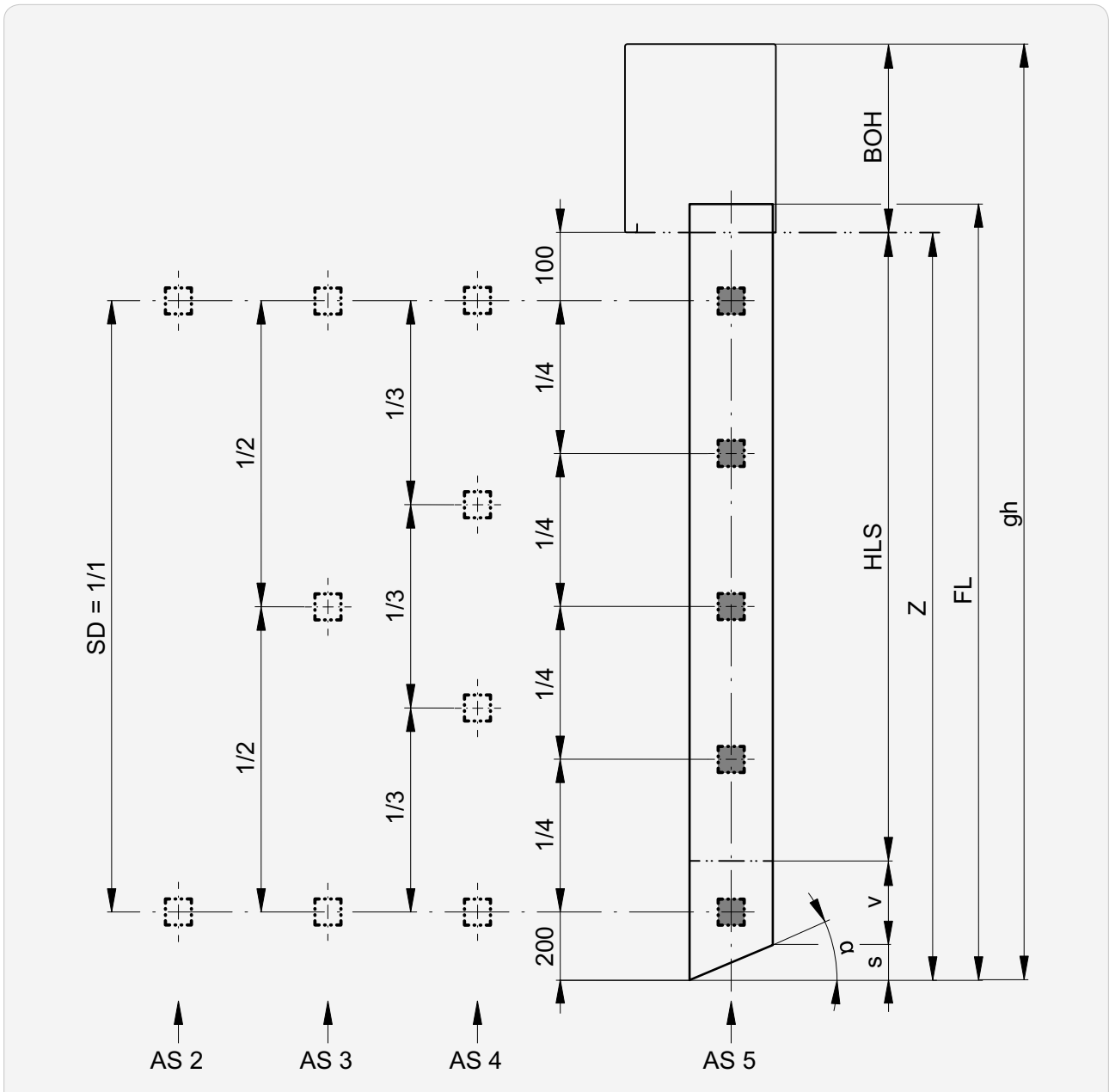

AS Number of slits

BOH Box height

s Faceting (guide rail width x tgα)

SD Slot spacing: max. 1200

v Guide rail extension: max. 1000

Technical data of motors

Performance characteristics

Type	Limit switch		M [Nm]	n [1/min.]	P [W]	I [A]
	Type	Number of				
Standard						
Elero						
ES...	06.01	mechanical	6	26	110	0.50
	09.01		9		170	0.75
EO...	20.01		20		190	1.05
ES...	06.51	mechanical	6	26	110	0.50
	09.51		9		170	0.75
EO...	20.51		20		190	1.05
Option						
Somfy						
SH...	06.01	mechanical	6	24	95	0.40
	10.01		10		110	0.65
	18.01		18		155	1.00
SW...	06.01		6		95	0.40
SI...	10.01	electronic	10	24	110	0.65
	18.01		18		155	1.00
Elero Comfort						
ECM...	06.01	electronic	6	26	115	0.50
	09.01		9		156	0.68
	06.51		3		115	0.50
	09.51		9		156	0.68
ECB...	06.01	electronic	6	26	115	0.50
	09.01		9		156	0.68
	06.51		3		115	0.50
	09.51		9		156	0.68
Geiger AIR						
GA...	06.01	electronic	6	26	93	0.40
	06.10		10		135	0.60
	06.20		20		190	0.85

I Current consumption

M Torque

n Rotational speed

P Power consumption



Lamisol® III Vento

Limit dimensions	152
Built-in system	153
Built-in system with cover	153
Header dimensions Heights of package	154
End rail	155
Slat profile	155
Beginning distance Slot spacing	156
Housing fastening	157
Number of box supports	159
Options	160
Guide rail	161
Sections Details	162
Vertical connections Standard motor position	163
Guide rail installation (principle)	165
Guide rail fastenings (principle)	167
Guide extension	170
Installation window	171
Fastening points	172
Connected systems	174
Technical data of motors	176



Limit dimensions

Single blind

Operation	Width min. (bk)	Width ^{1,2} max. (bk)	Height min. (hl)	Height max. (hl)	Surface max. [m ²]
Motor drive	695 700 ³	3000	400	3000	9

Connected systems

Operation	Width ¹ max. (bk)	Blinds max.	Blinds per system	Surface max. [m ²]
Motor drive	9000	3	2 3	16 20

¹ For buildings and high-rise structures, which are exposed to high winds, this maximum value should be decreased as required. Also see wind classes data sheet.

² **bk > 2500**: mount housing with an additional box support.

³ Radio motor Geiger AIR

 Soffit installation or suspended installation: max 100

Built-in system

Vertical section

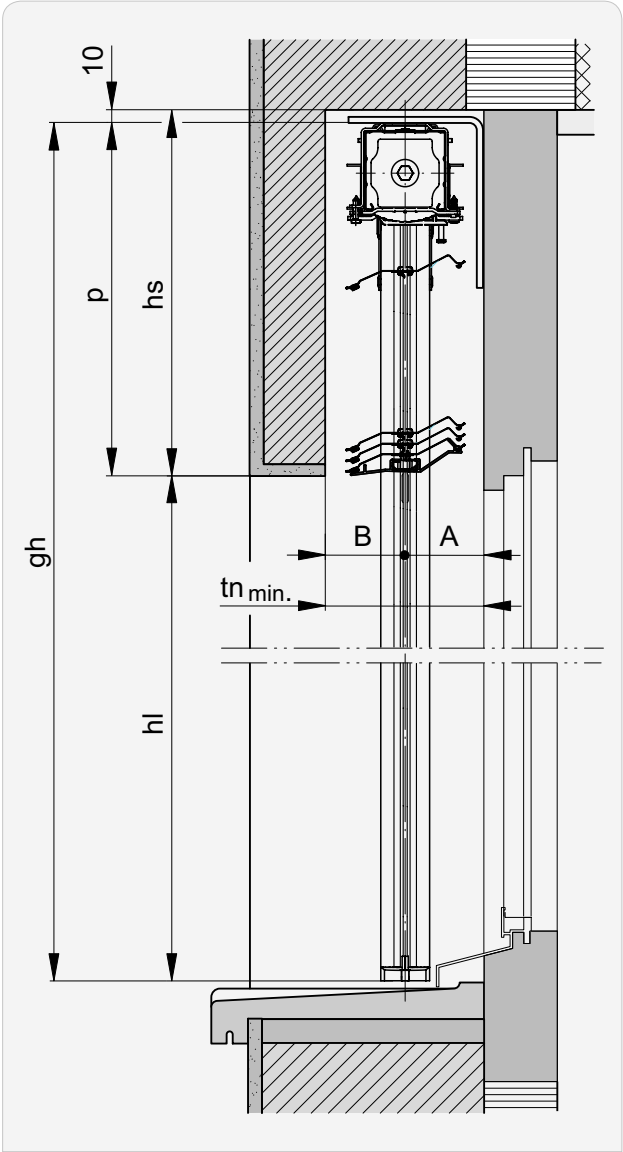

Built-in system with cover

Vertical section

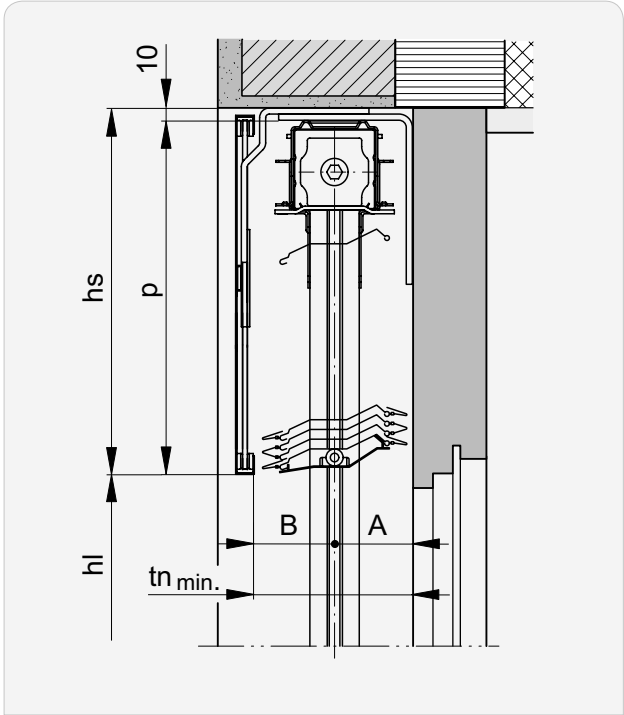

Horizontal section

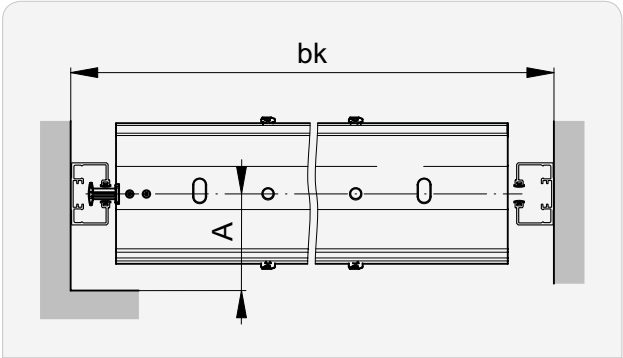

Header dimensions | Heights of package

hl → ¹		hs ¹
1800	215	225
1950	220 min.	230
2050	225	235
2100	230	240
2200	235	245
2300	240	250
2350	245	255
2500	250	260
2600	255	265
2650	260	270
2750	265	275
2800	270	280
2900	275	285
3000	280	290

tn min.	A	B
130*	65	65

¹ Lamisol® III Vento Reflect: **hs + 5**.

* + possible addition for protruding weatherboard or doorknobs.

i Header dimensions are approximate values which may exhibit **negative or positive deviations** depending on the technical circumstances. **A dimensional tolerance of ±5 mm** is observed for the header height.

Stat profile

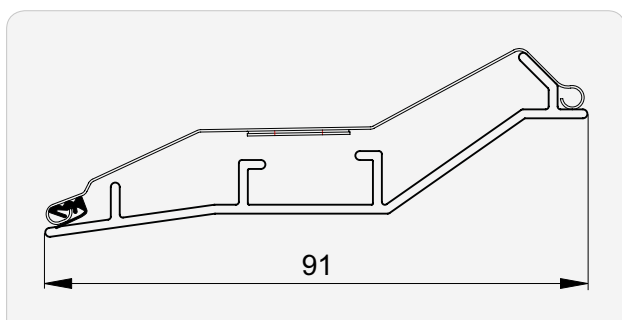
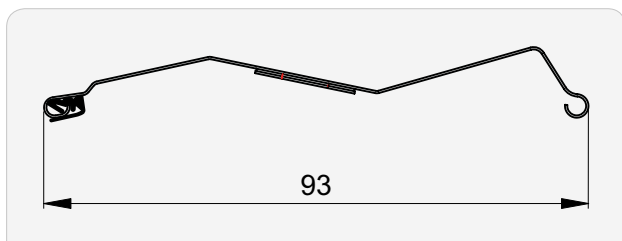

Beginning distance | Slot spacing

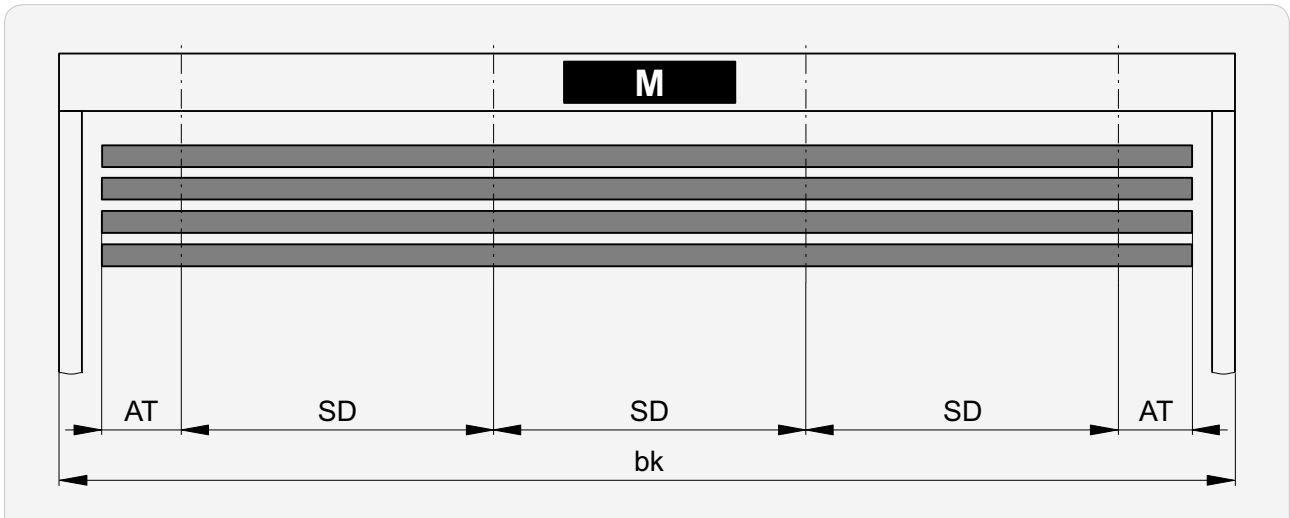

bk	AT min.	SD min.	SD max.
≤1250	100	350*	1000*
>1250	200		

* Standard slot spacing machine fabrication

Deviations from the standard are possible when:

Deviation	Correction
Support loading too high	AS
Slot spacing < 350	AT + AS
With motor	AT + AS

Housing fastening

At top

NO

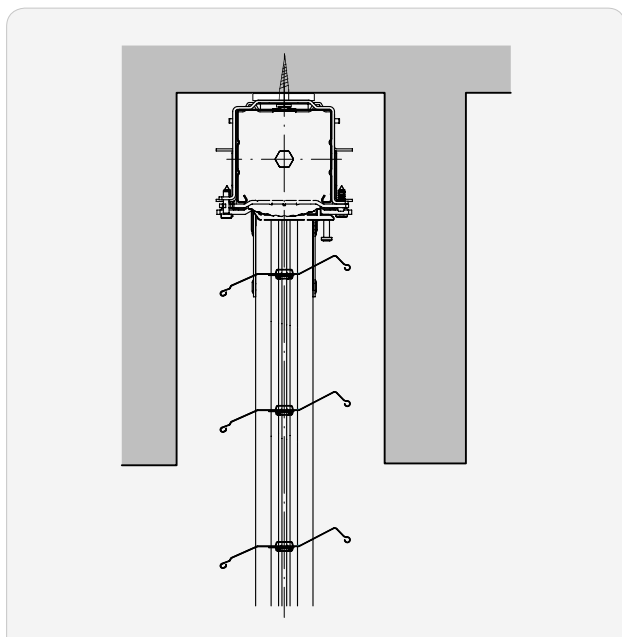

Box support

KT

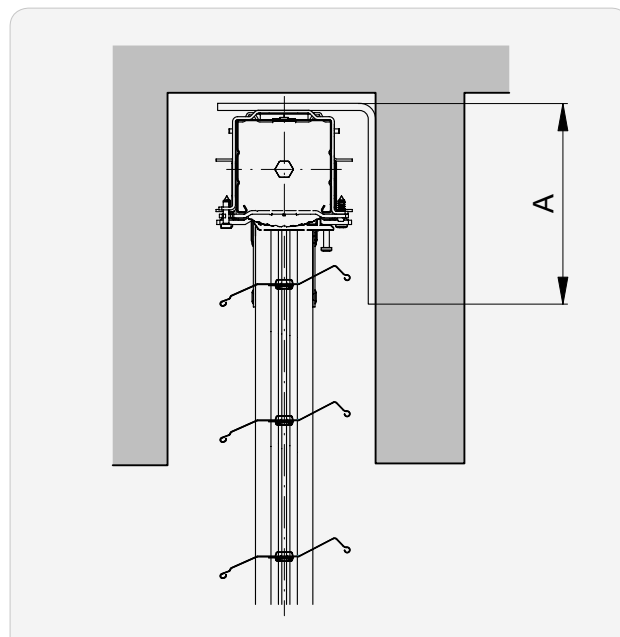

Box support for type KT, for small headers*

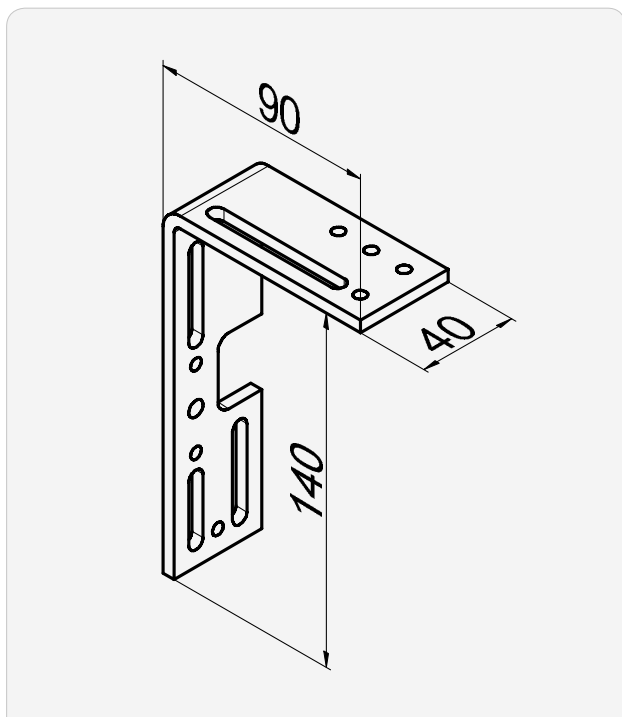

A

140

Box support for type KT

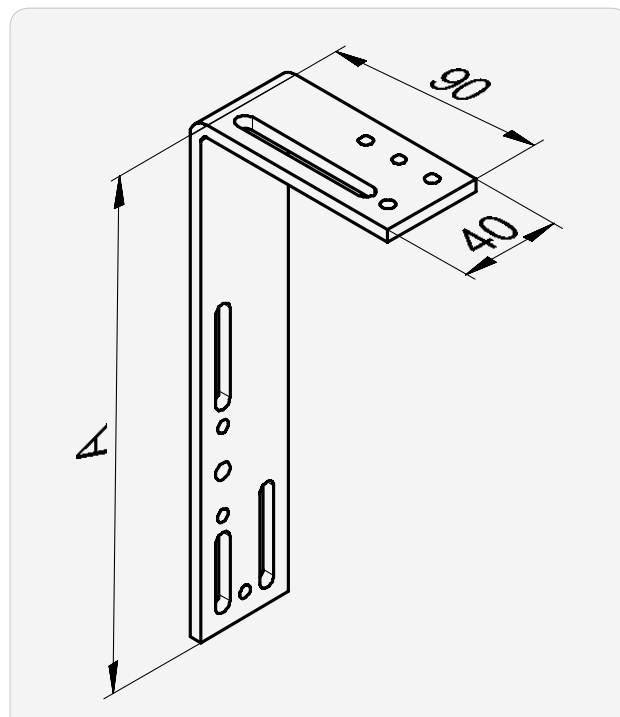

A

200

260

* Header 100

►► Housing fastening

Double box support

DR

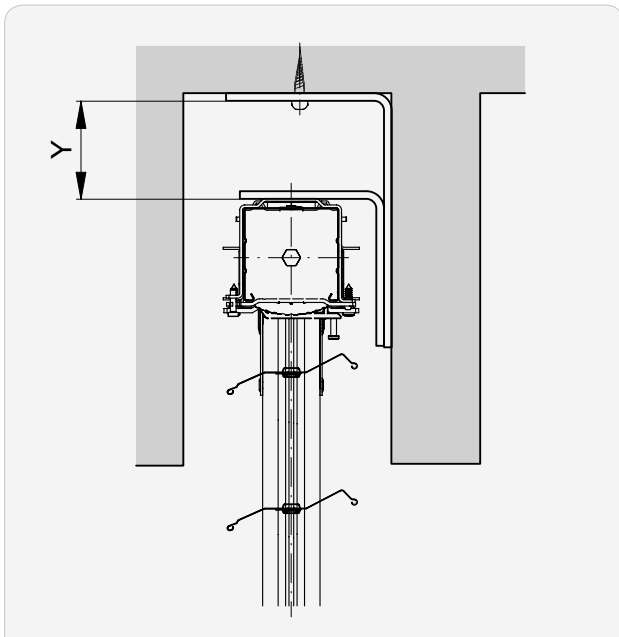

Gallery clip

GB

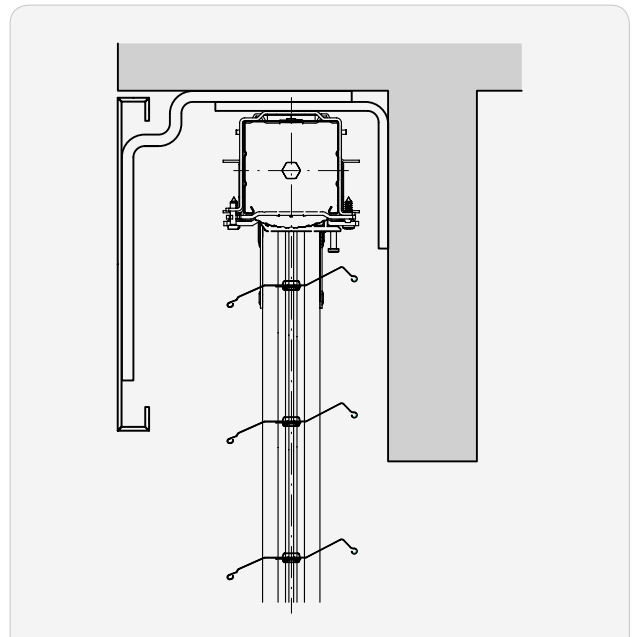

Double box support for type DR

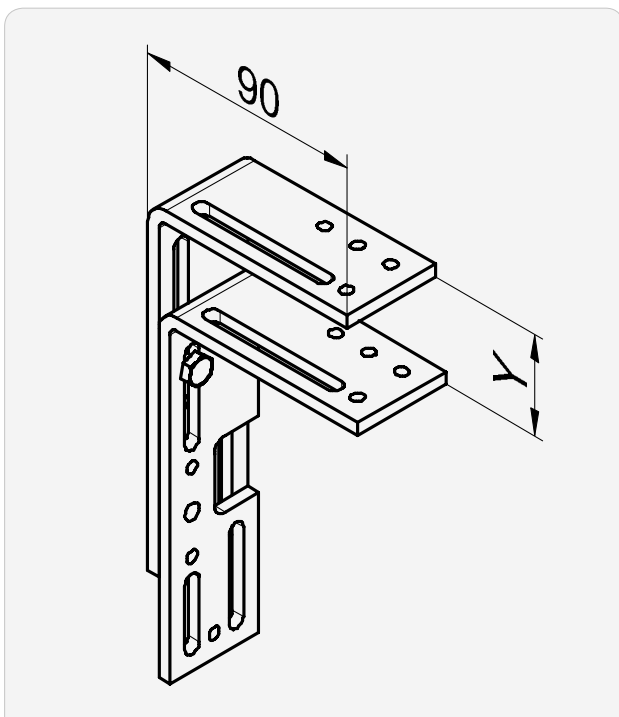

Gallery clip for type GB

i See additional documentation:
Short manual "Covers"



[↓ Covers](#)



Y

10... 75

75... 135

135... 200

Number of box supports

Fix guides | Additional fastenings

bk	Quantity
≤ 2500	0
2501 ... 3500	1
> 3500	2

Options

Lamisol® III Vento Reflect

i For glare protection at bottom and use of daylight at top.

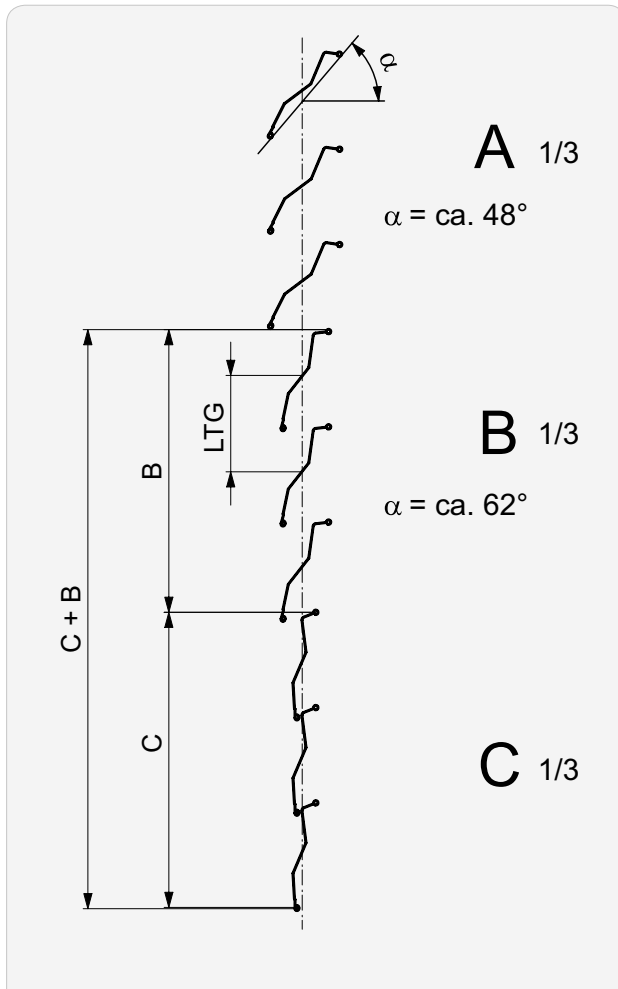

i For technical reasons, the Reflect zone (**C + B**) must be two slat spacing units larger than the Reflect zone **C**.

- A** Use of daylight
- B** Ability to see outside
- C** Glare protection
- LTG** Slat spacing

Guide rail

Type F | Fix guide

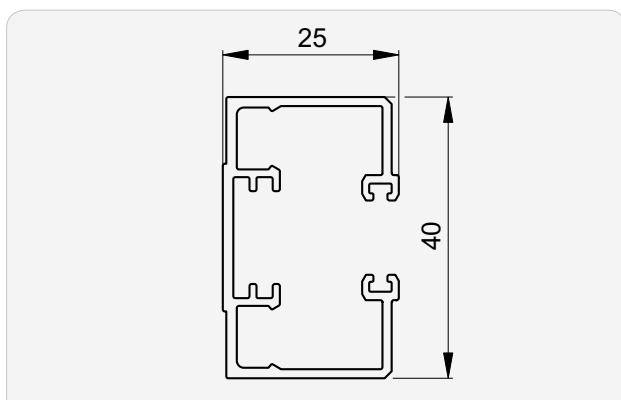

➔ Distance between guides FD	174	➔ Guide rail fastenings	167
➔ Fastening points	172	➔ Installation window.....	171
➔ Guide extension and facet.....	170	➔ Integrated guides	166

Sections | Details

Detail of section

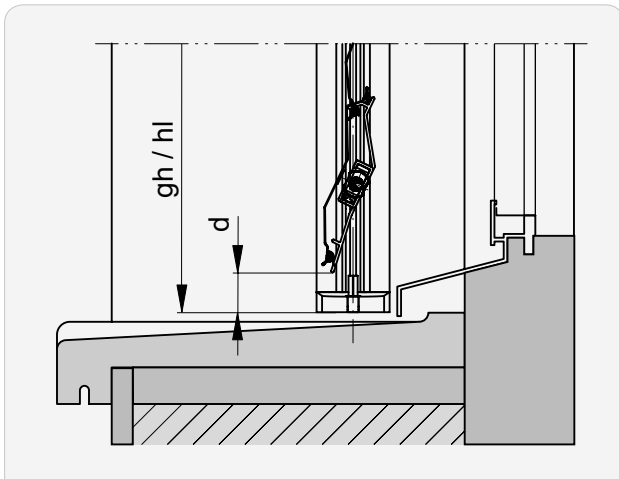
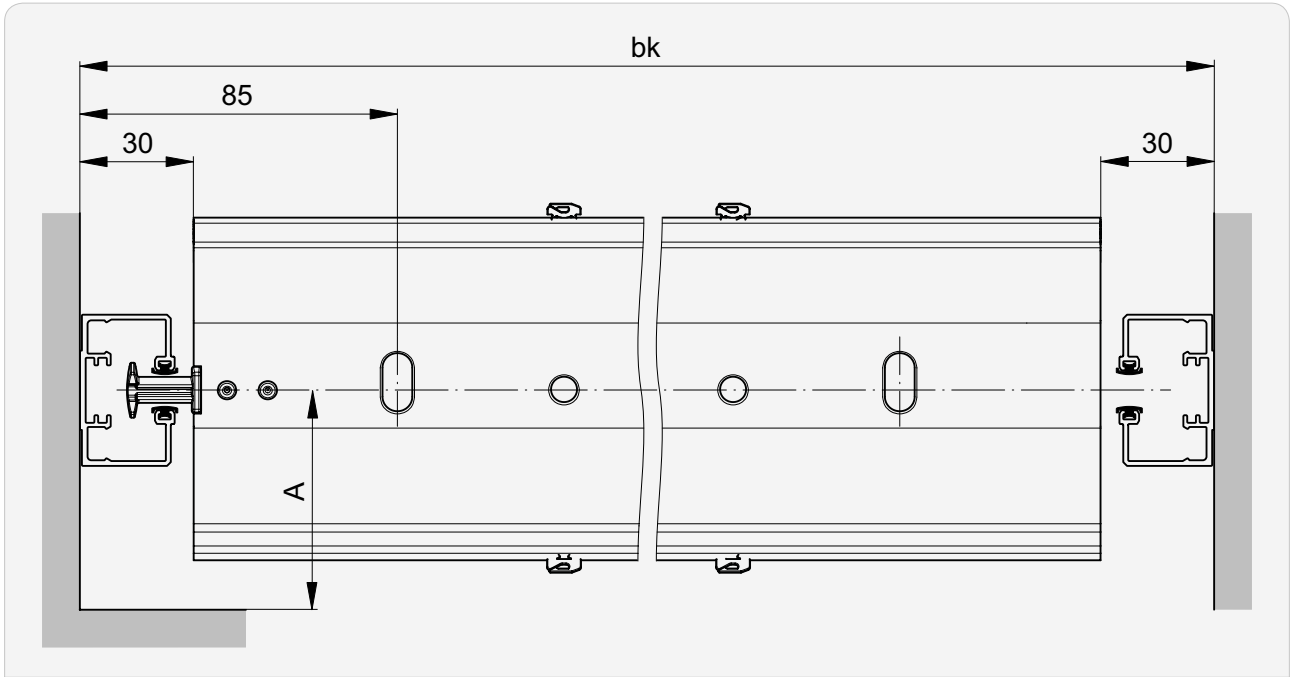

d (d-dimension)

15 +5/-3 (Lamisol® III Vento Reflect: 25 +5/-3)

i d-dimension may vary with different blind dimensions.

➡ Value for A 154



Vertical connections | Standard motor position

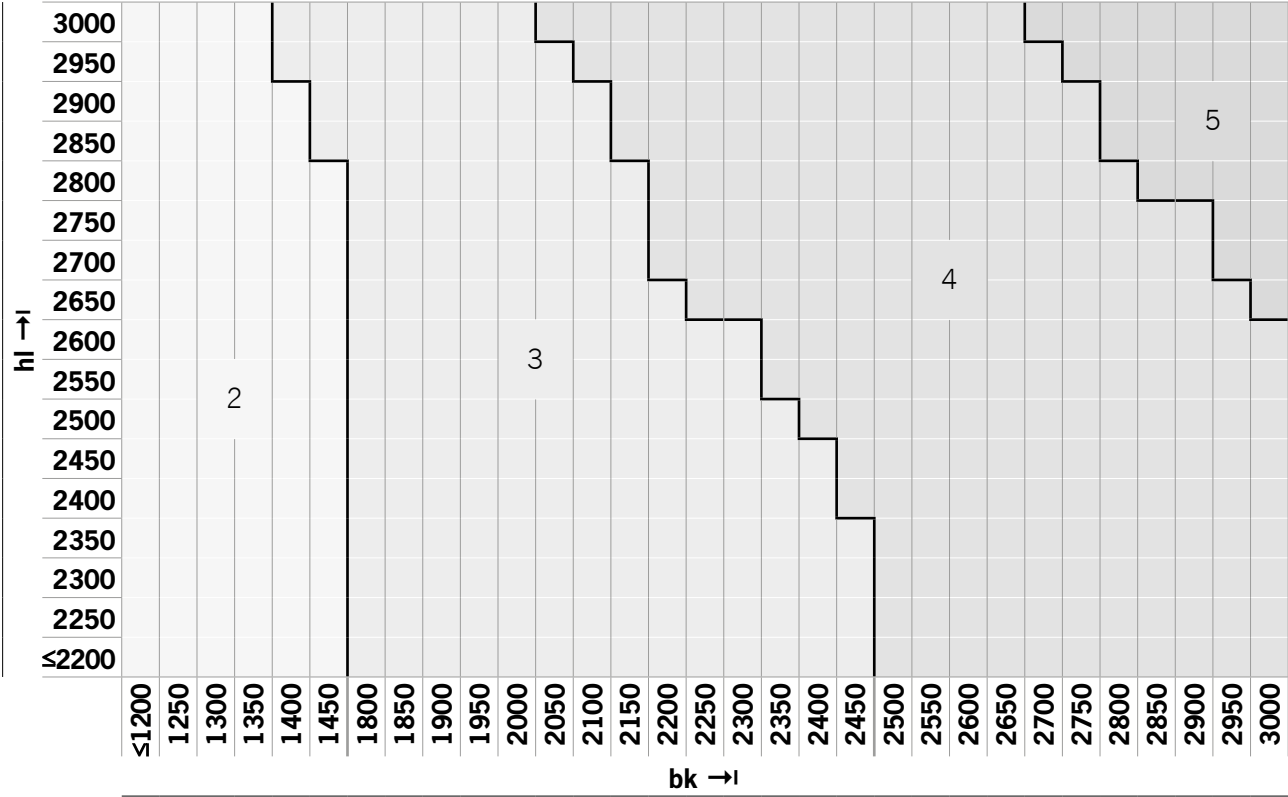

Number of bearings

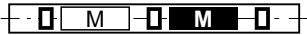

▶▶ Vertical connections | Standard motor position

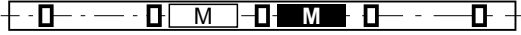
Standard motor position

Number of bearings	Standard motor position
2	
3	
4	
5	

-  Bearing
-  Standard motor position
-  Possible motor position (on request)

Guide rail installation (principle)

Guides attached (to soffit) | Type A

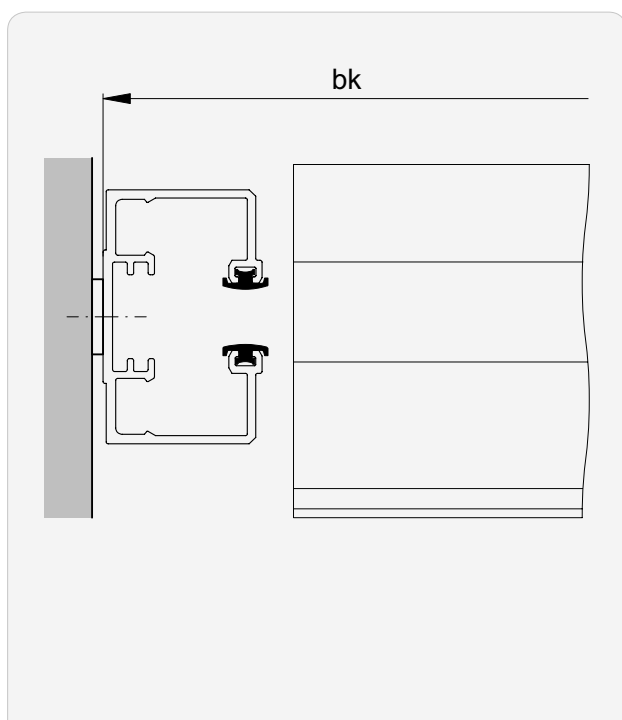

Guides suspended

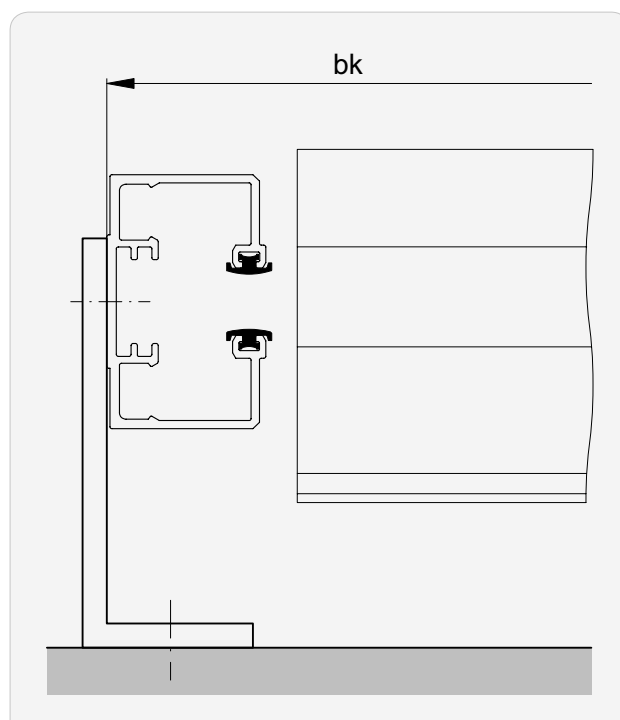

i Observe possible guide rail spacer for **bk**.
Standard: 2 mm

►► Guide rail installation (principle)

Guides recessed

Type F*

i *Type F | Without guide cut-out:
Only possible if curtain can be retracted from below.

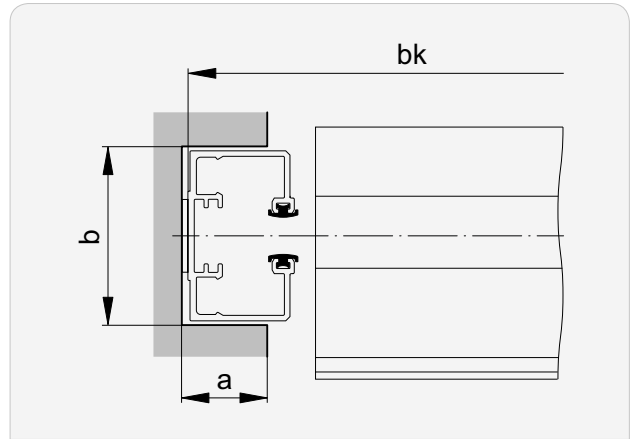
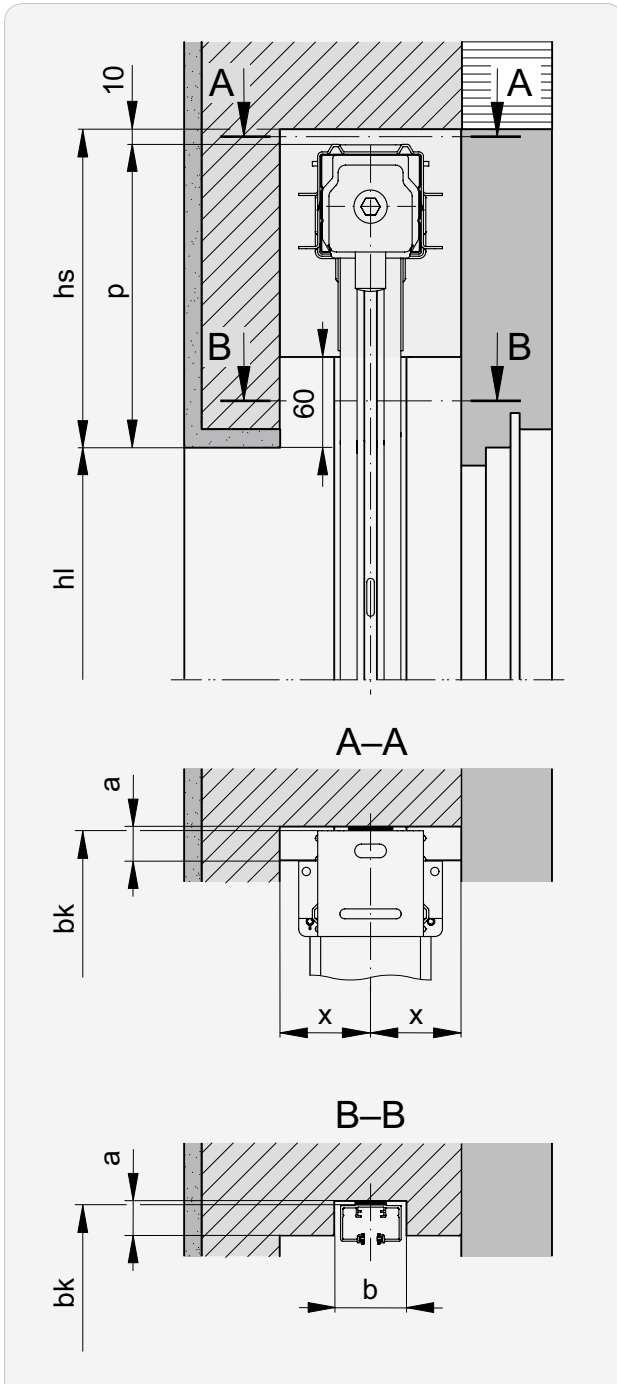

a	b
≤ 20	≥ 42

Product Version	x min.
Lamisol® III 90 Vento	65

Guide rail fastenings (principle)

Overview

															Type
A	B	Bd	C	Cd	E	F	G	H	Kv	M	T	Tv	V	Wv	
●	–	○ ¹	–	○ ¹	–	–	–	–	–	–	–	–	○ ²	–	

- applicable without restrictions
- applicable with restrictions:
 - ¹ A = max. 100
 - ² only with continuous fastening bracket

A Soffit installation

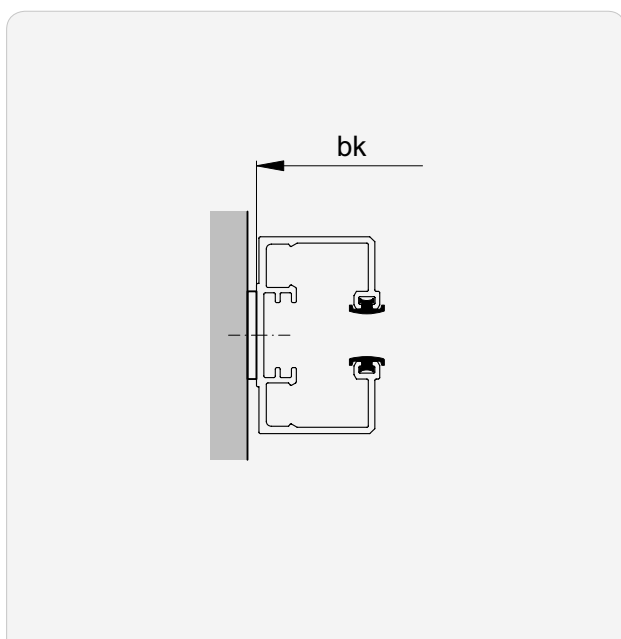

i Observe possible guide rail spacer for **bk**.
Standard: 2 mm

►► Guide rail fastenings (principle)

Bd Installation with continuous fastening bracket

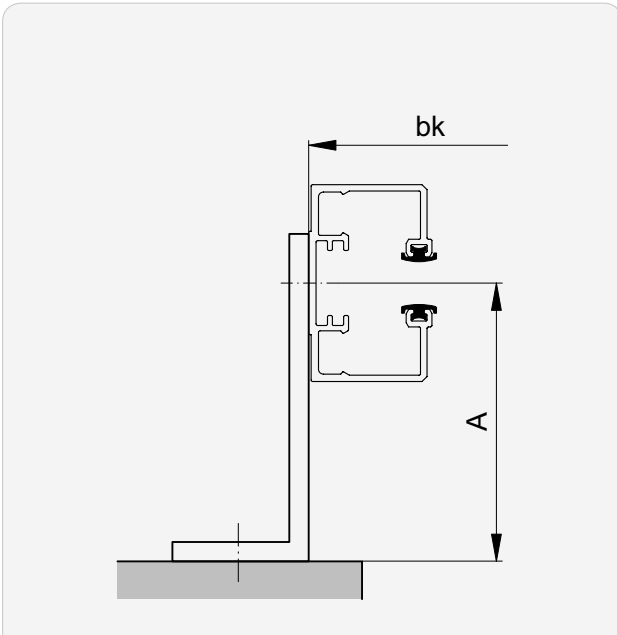

Bracket outwards

Cd Installation with continuous fastening bracket

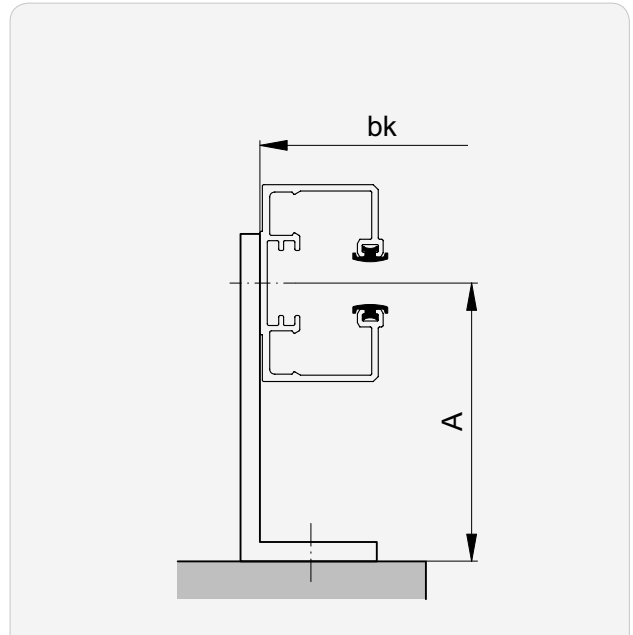

Bracket inwards

Continuous fastening bracket for types Bd and Cd

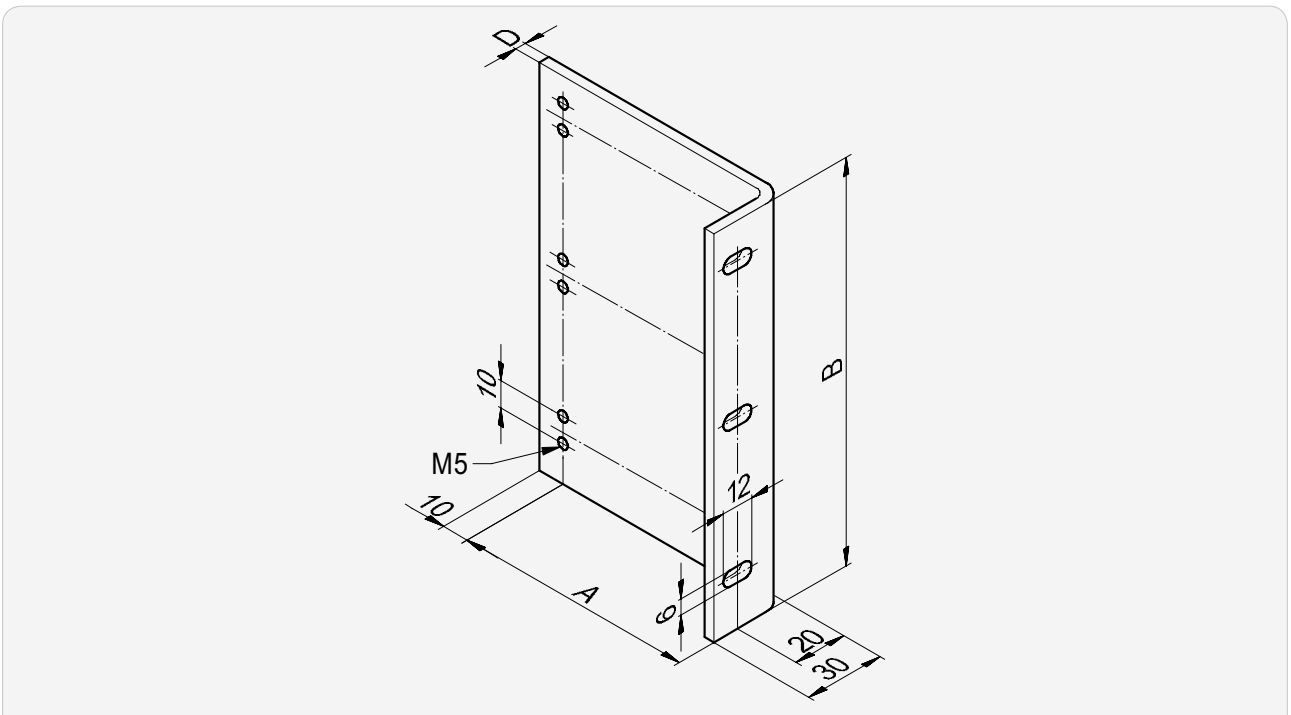

A*

20...300

D

always 4

* in 5 mm steps

►► Guide rail fastenings (principle)

V Installation with one bracket

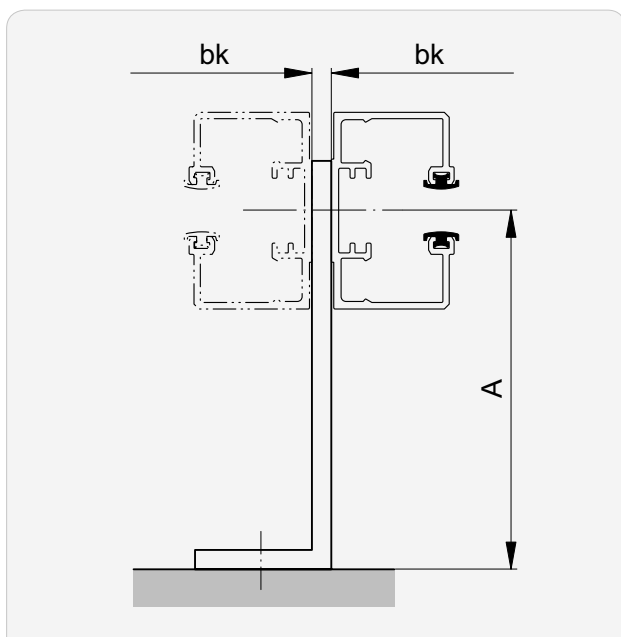

The blind on the right uses the fastening for the blind on the left.

Guide extension

Extension

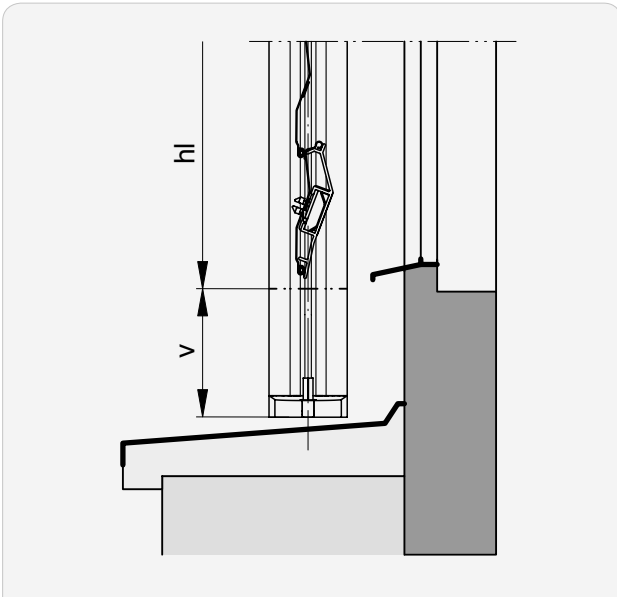

v
0 ... 500

Installation window

Without extension

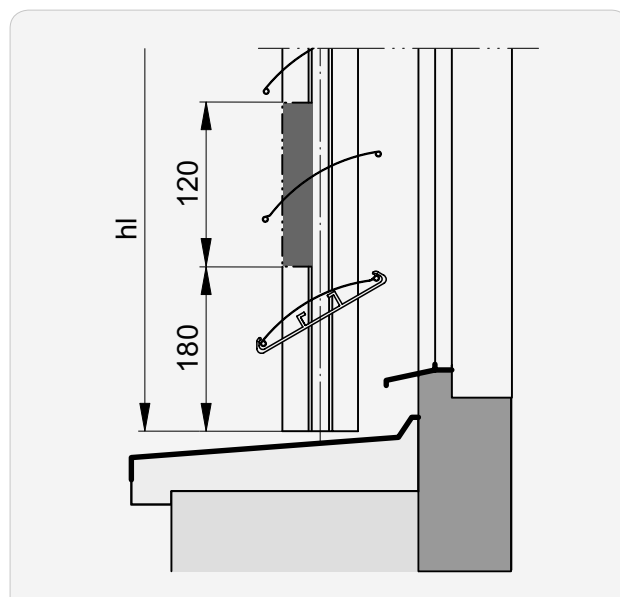
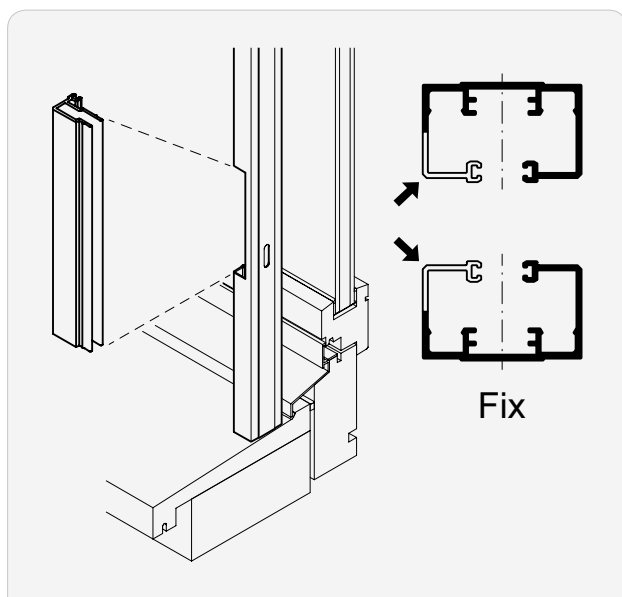

With extension

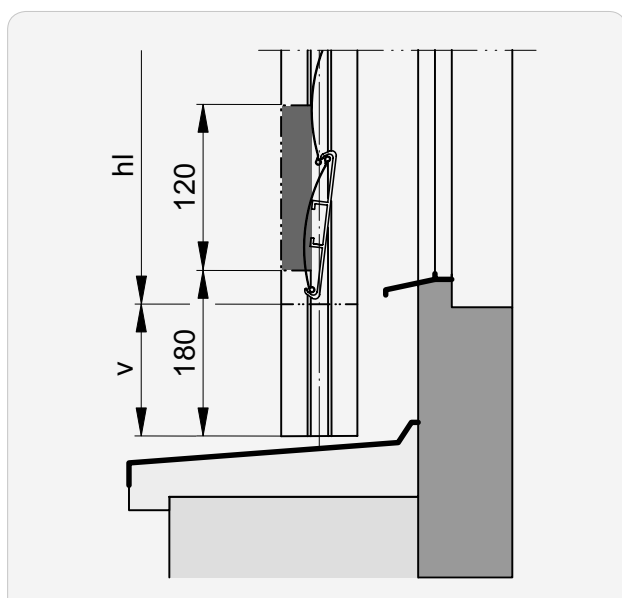

v Guide rail extension: max. 1000

Fastening points

Without extension

Z	AS
≤ 740	2
741 ... 1340	3
1341 ... 1940	4
1941 ... 2540	5
> 2540	6

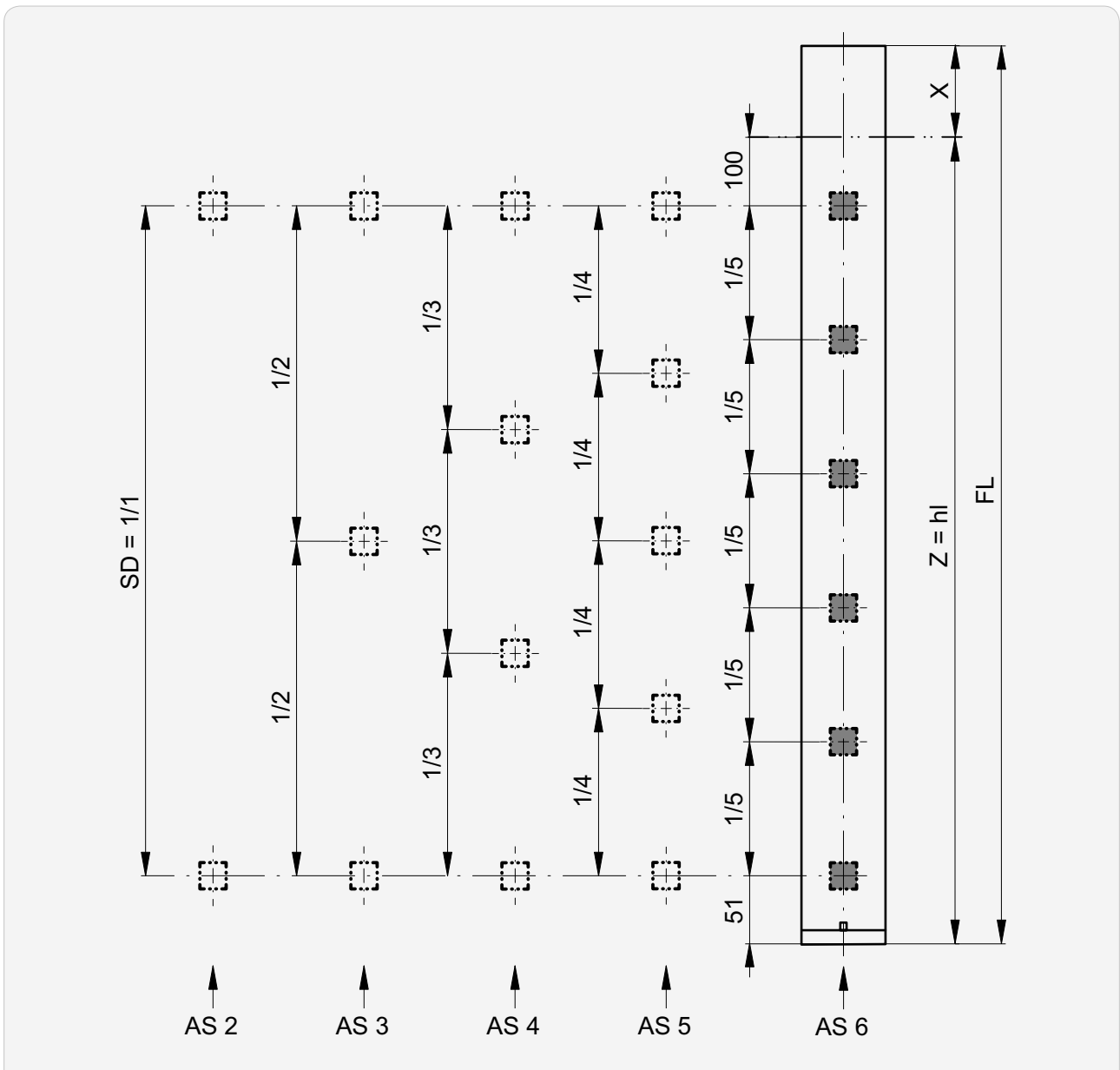

AS Number of slits

SD Slot spacing: max. 600

►► Fastening points

With guide rail extension

Z	AS
≤ 740	2
741 ... 1340	3
1341 ... 1940	4
1941 ... 2540	5
> 2540	6

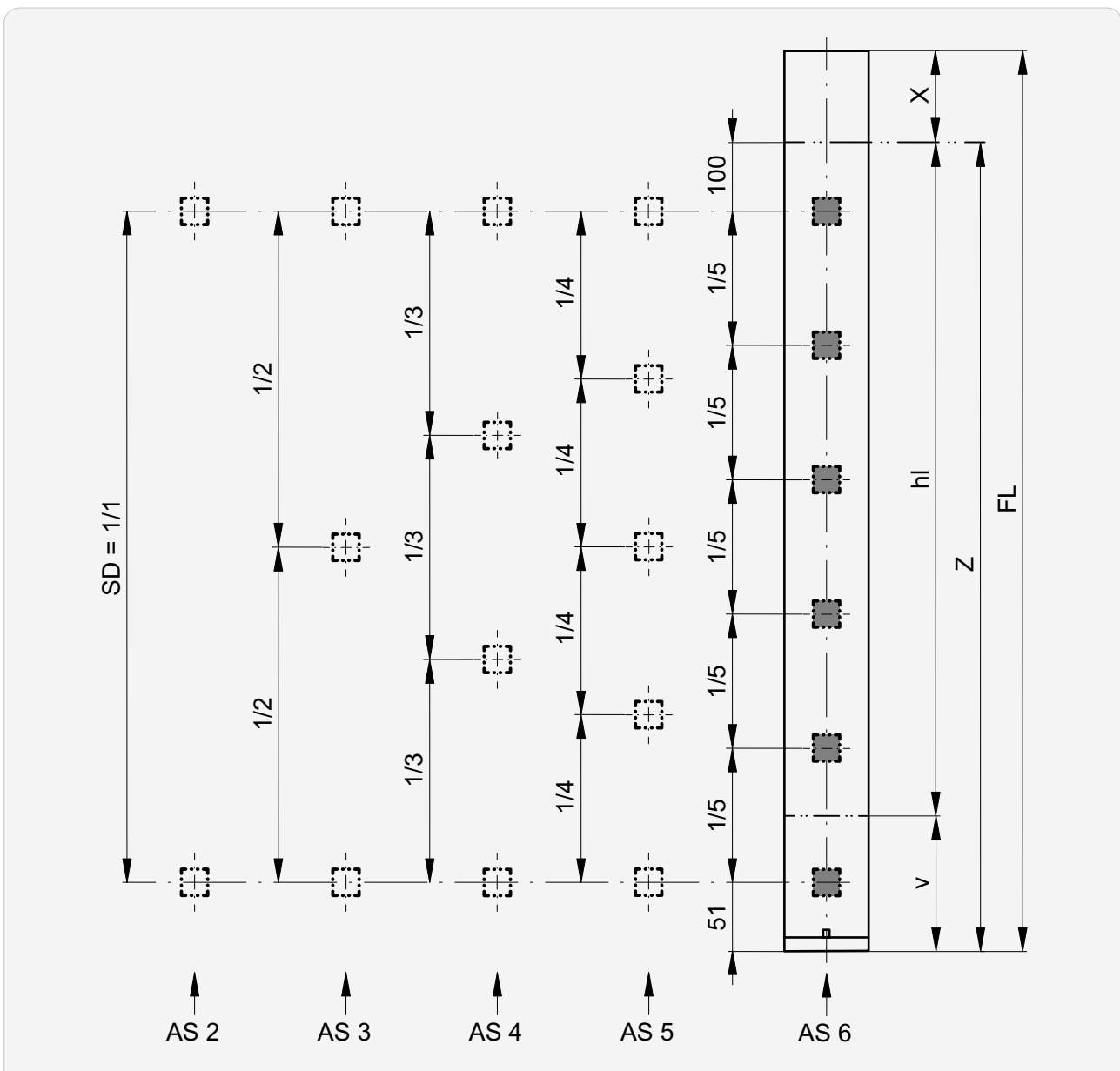

AS Number of slits

v Guide rail extension: max. 500

SD Slot spacing: max. 600

► Guide extension..... 170
 ► Guide rail fastenings 167

► Installation window..... 171

Connected systems

System width

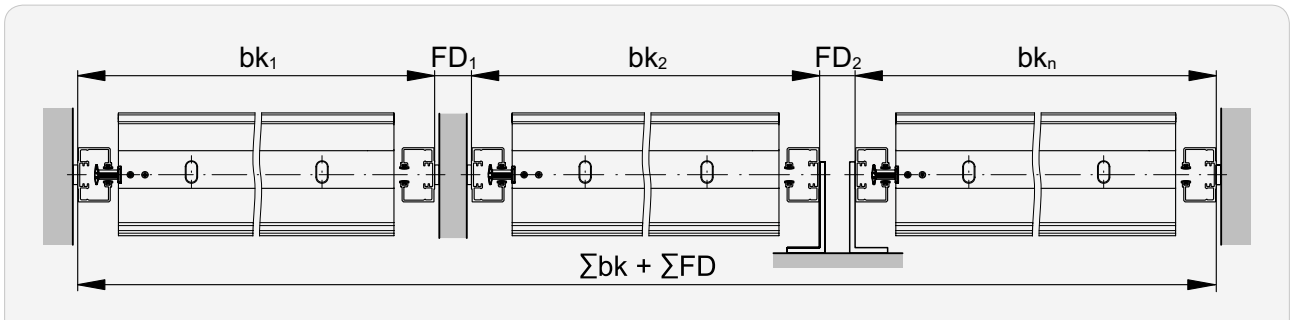

Distance between guides FD

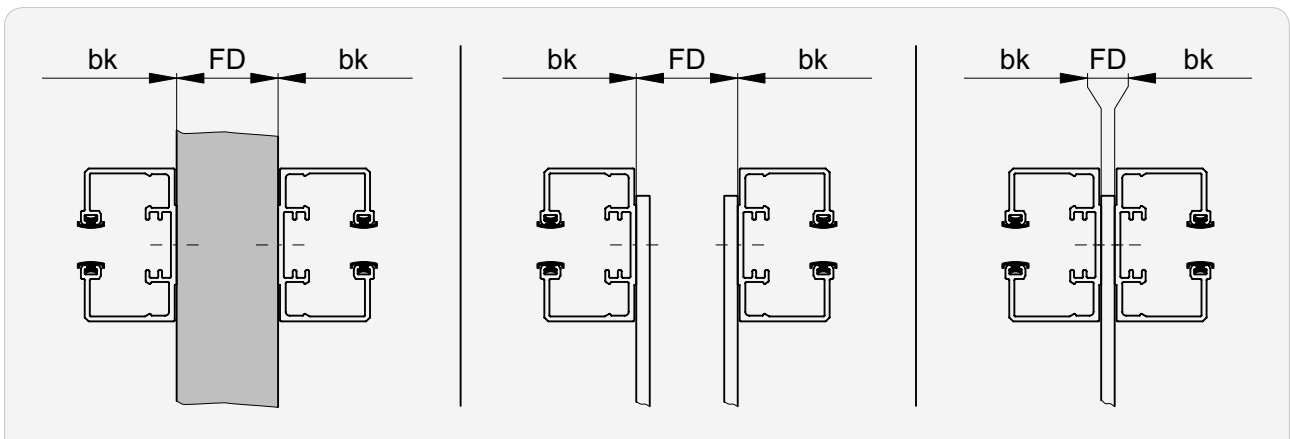

FD min.	FD max.
5	1000

▶▶ Connected systems

Diagrams for connected blinds

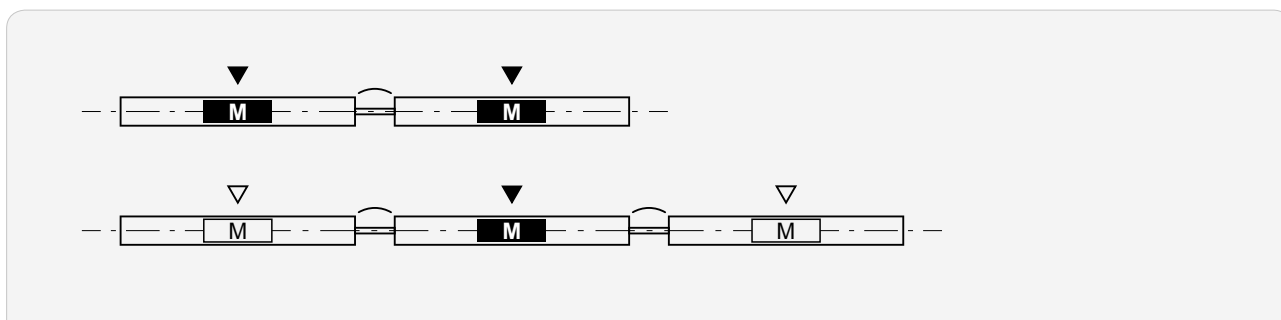

▼ Standard drive position

▽ Possible drive position

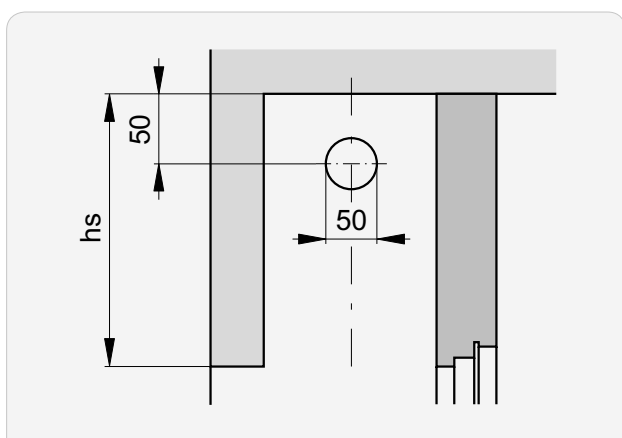

Technical data of motors

Performance characteristics

Type	Limit switch		M [Nm]	n [1/min.]	P [W]	I [A]
	Type	Number of				
Standard						
Elero						
ES...	06.01	mechanical	6	26	110	0.50
	09.01		9		170	0.75
EO...	20.01		20		190	1.05
ES...	06.51	mechanical	6	26	110	0.50
	09.51		9		170	0.75
EO...	20.51		20		190	1.05
Option						
Somfy						
SH...	06.01	mechanical	6	24	95	0.40
	10.01		10		110	0.65
	18.01		18		155	1.00
SW...	06.01		6		95	0.40
SI...	10.01	electronic	10	24	110	0.65
	18.01		18		155	1.00
Elero Comfort						
ECM...	06.01	electronic	6	26	115	0.50
	09.01		9		156	0.68
	06.51		3		115	0.50
	09.51		9		156	0.68
ECB...	06.01	electronic	6	26	115	0.50
	09.01		9		156	0.68
	06.51		3		115	0.50
	09.51		9		156	0.68
Geiger AIR						
GA...	06.01	electronic	6	26	93	0.40
	06.10		10		135	0.60
	06.20		20		190	0.85

I Current consumption

M Torque

n Rotational speed

P Power consumption

Aluflex®

Limit dimensions Aluflex®	180
Limit dimensions Aluflex® Box	180
Built-in system	181
Built-in system with cover	183
Installation system with Box	185
Header dimensions Heights of package	187
Slat profiles	188
End rails	188
Beginning distance Slot spacing	189
Housing fastening	190
Number of box supports	192
Fixation for box base profile	193
Technical data of motors	194
Options	195

Rail guide

Guide rails	196
Sections Details	197
Sections for crank drive (MBMA)	200
Additional cables	201
Vertical connections Standard motor position	202
Guide rail installation (principle)	205
Guide rail fastenings (principle)	207
Guide extension and facet	215
Guide rail cut-outs in windowsill area	218
Guide rail end for suspended guide rails	219
Guide extension for window sill installation	219
Installation window	220
Fastening points	221
Connected systems	225

Cable guide

Cable guide	227
Sections Details	227
Sections for crank drive (MBMA)	229
Additional cables	230
Vertical connections Standard motor position	231
Cable fastenings	234
Connected systems	236



Limit dimensions Aluflex®

Single blind

Operation	Width min. (bk)	Width ² max. (bk)	Height min. (hl)	Height max. (hl)	Surface ³ max. [m ²]
Crank drive	550*	4500 ⁶ 5000 ⁷	550	4500 4000 ⁵	11
Motor drive	625 630 ⁵				20

Connected systems

Operation	Width ² max. (bk)	Blinds max.	Surface ³ max. [m ²]
Crank drive ¹	10 000	4	11
Motor drive ⁴			24

¹ A max. of 2 blinds may be connected on each side of the gearbox.

* with MBMA– on request

Limit dimensions Aluflex® Box

Single blind

Operation	Width min. (bk)	Width ² max. (bk)	Height min. (gh)	Height max. (gh)	Surface ³ max. [m ²]
Motor drive	625 630 ⁵	4500 ⁶ 5000 ⁷	735	4760 4000 ⁵	11

Connected systems

Operation	Width ² max. (bk)	Blinds max.	Surface ³ max. [m ²]
Motor drive ⁴	10 000	4	24

² For buildings and high-rise structures, which are exposed to high winds, this maximum value should be decreased as required. Also see wind classes data sheet.

³ If crank drive is in slat area: maximum surface area and crank position available on request.

⁴ For 3 or 4 blinds, the motor should be positioned in the center..

⁵ Radio motor Geiger AIR

⁶ Aluflex® guide rails

⁷ Aluflex® cable guide

Built-in system

Vertical section: Guide rail conventional

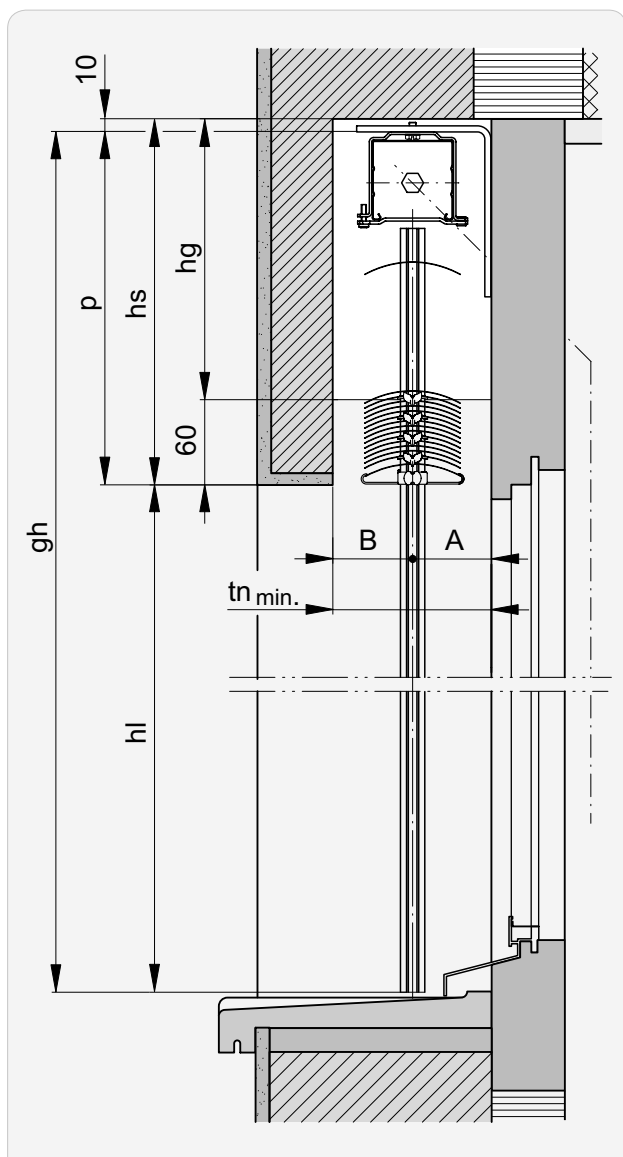

Vertical section: Guide rail Fix-L

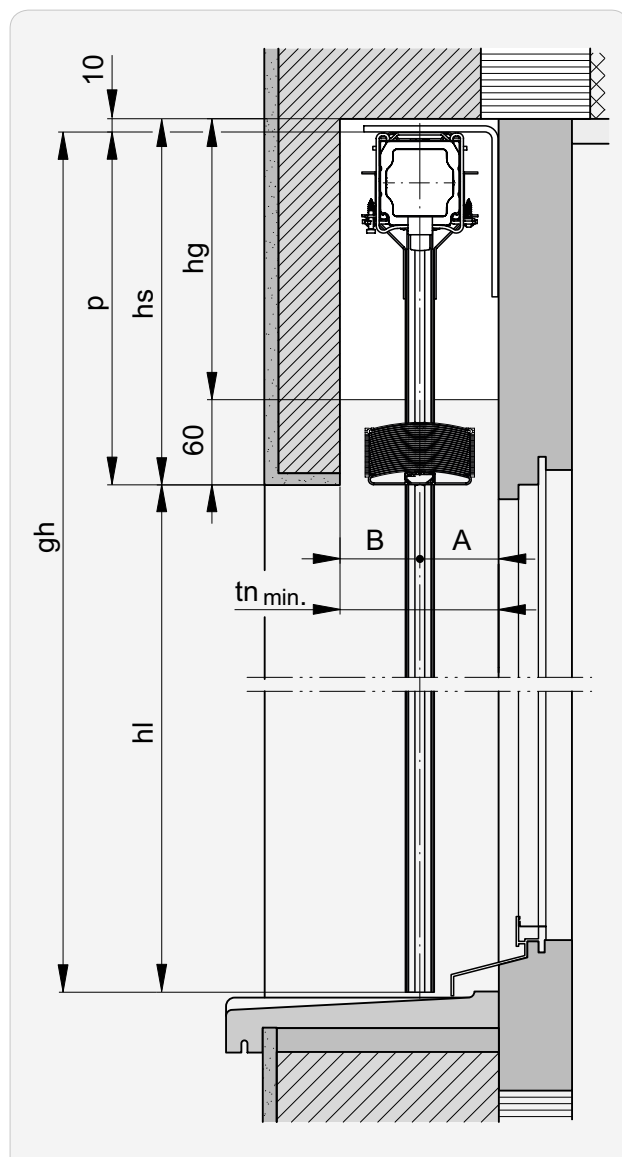

Horizontal section: Guide rail conventional

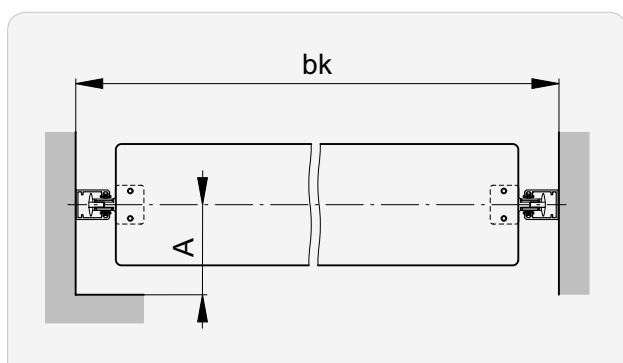

Horizontal section: Guide rail Fix-L

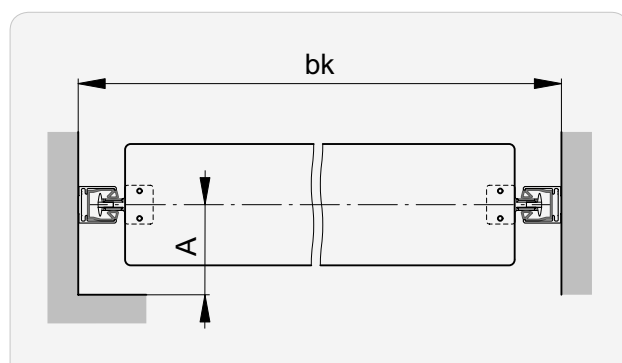

➤ Sections | Details..... 197

➤ Values for A, B and tn..... 187

►► Built-in system

Vertical section: Guide rail Fix

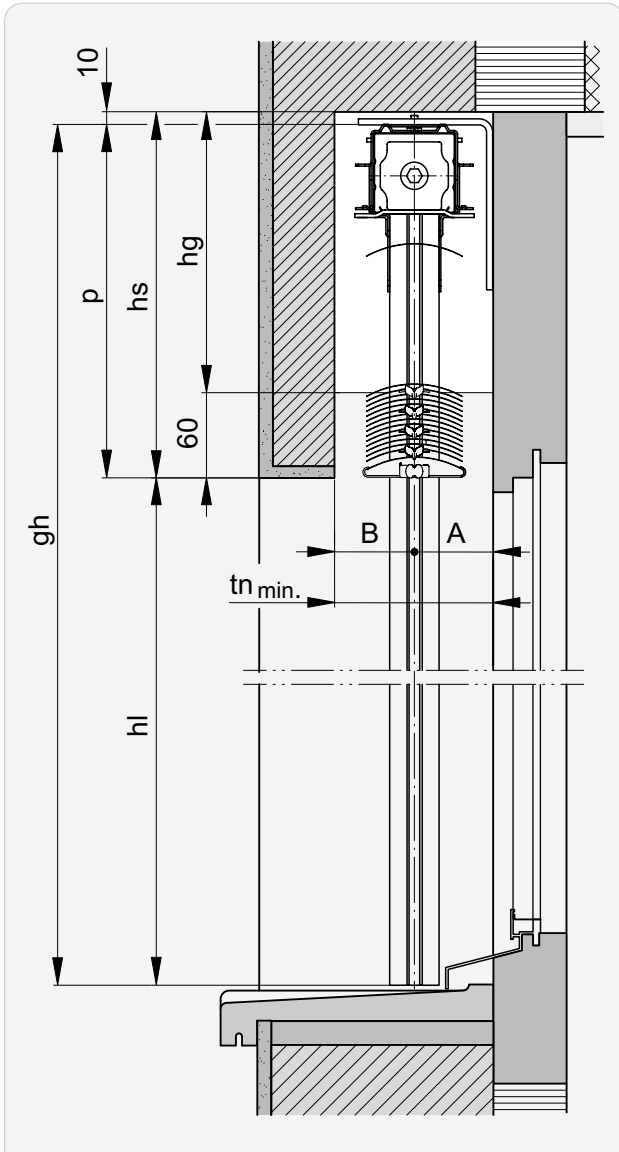

Vertical section: Cable guide

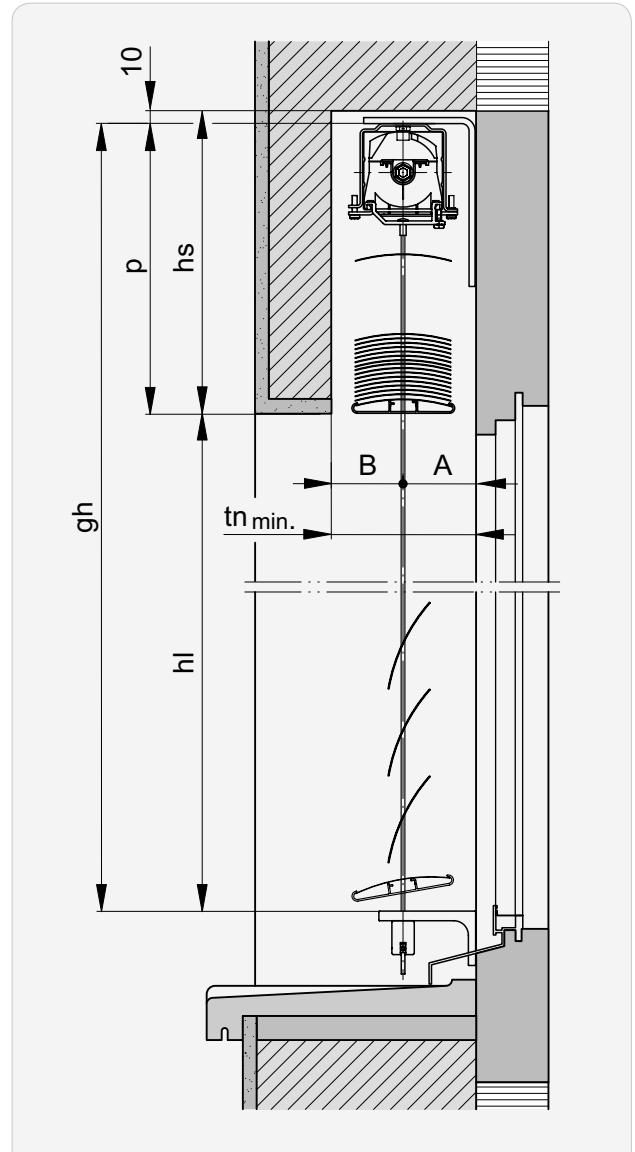

Horizontal section: Guide rail Fix

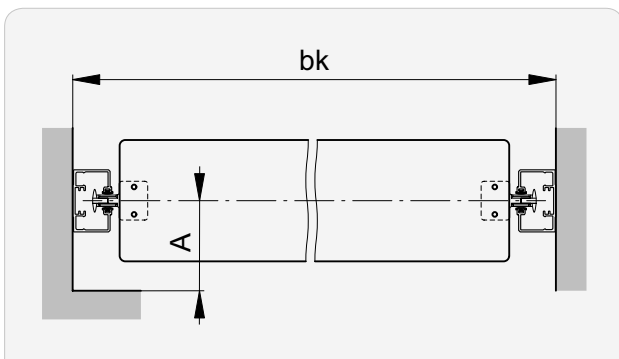

Horizontal section: Cable guide

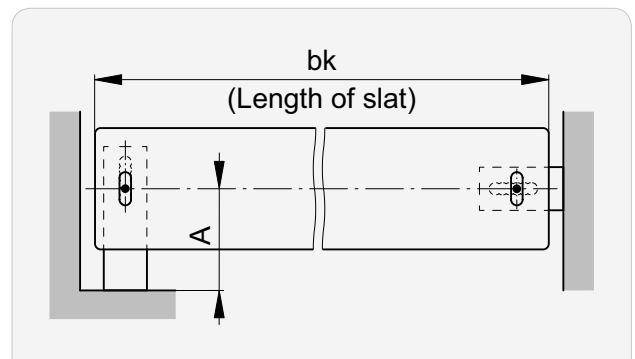

Built-in system with cover

Vertical section: Guide rail conventional

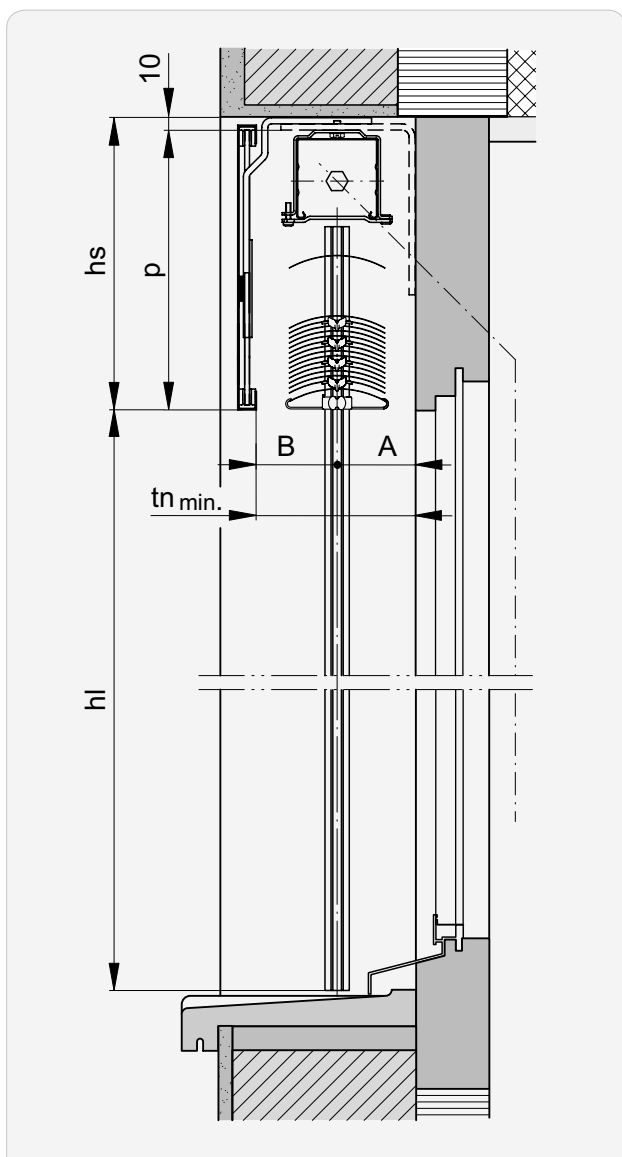

Vertical section: Guide rail Fix-L

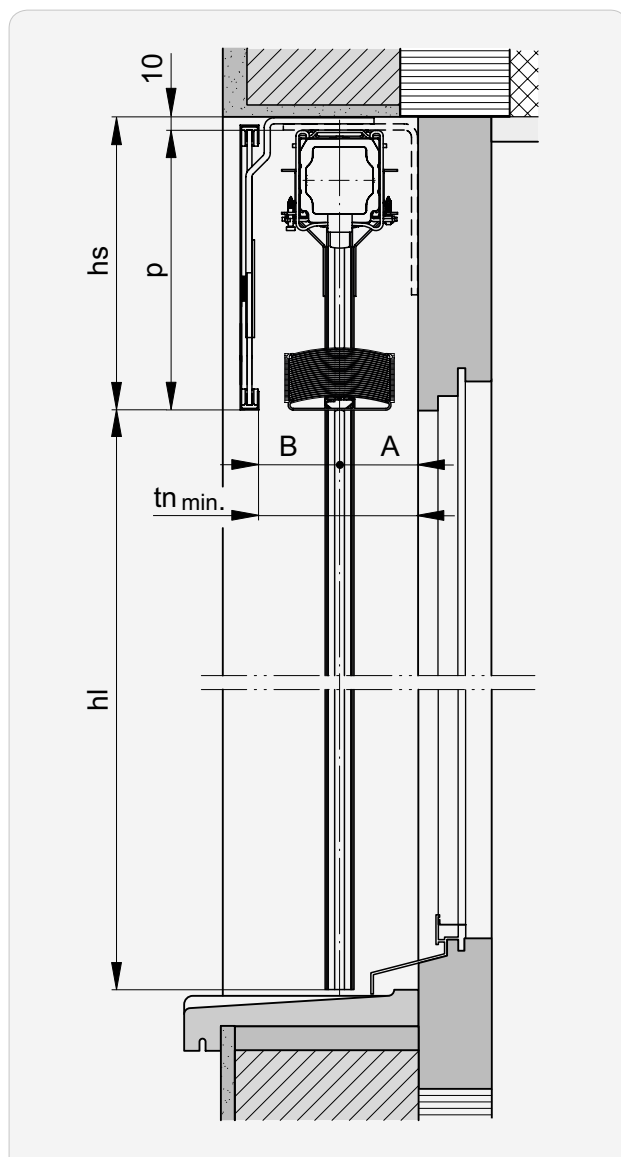

Horizontal section: Guide rail conventional

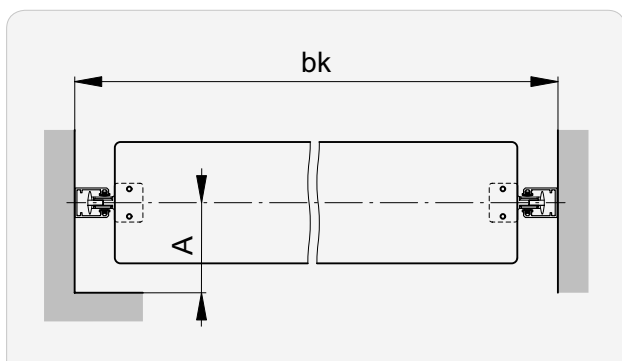

Horizontal section: Guide rail Fix-L

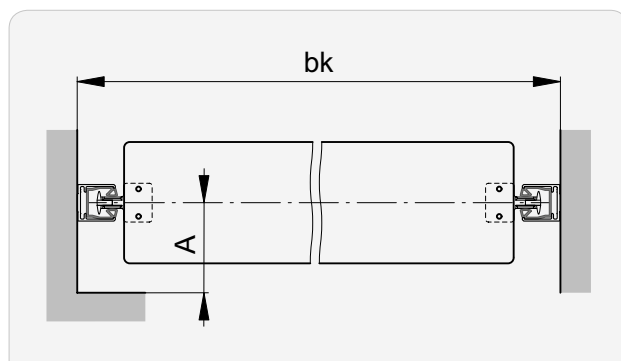

►► Built-in system with cover

Vertical section: Guide rail Fix

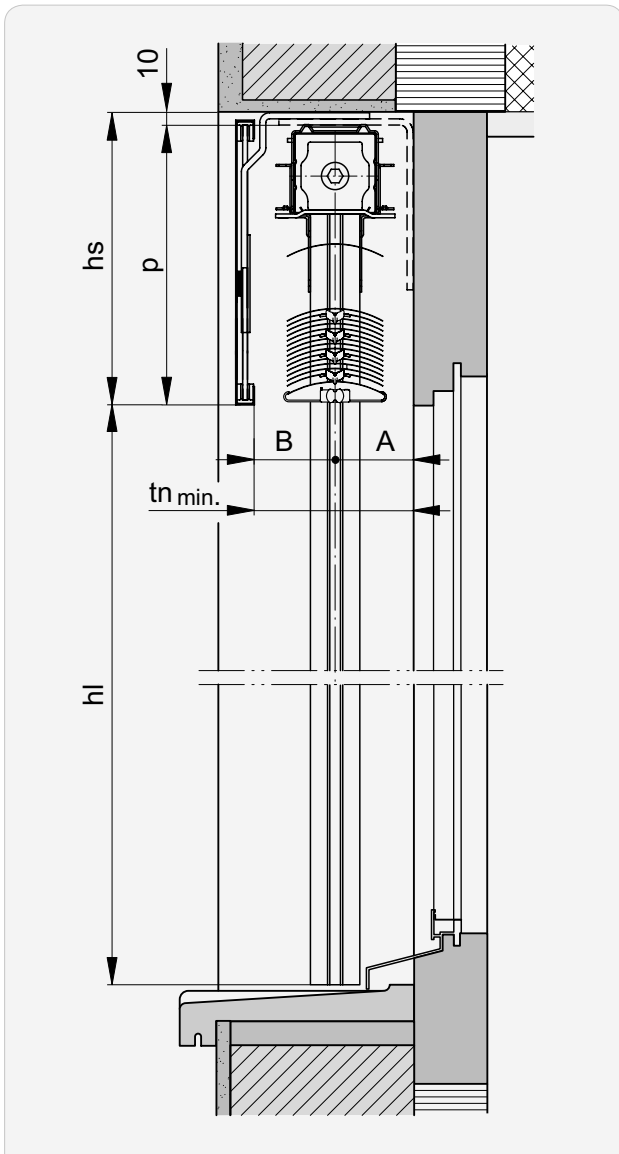

Vertical section: Cable guide

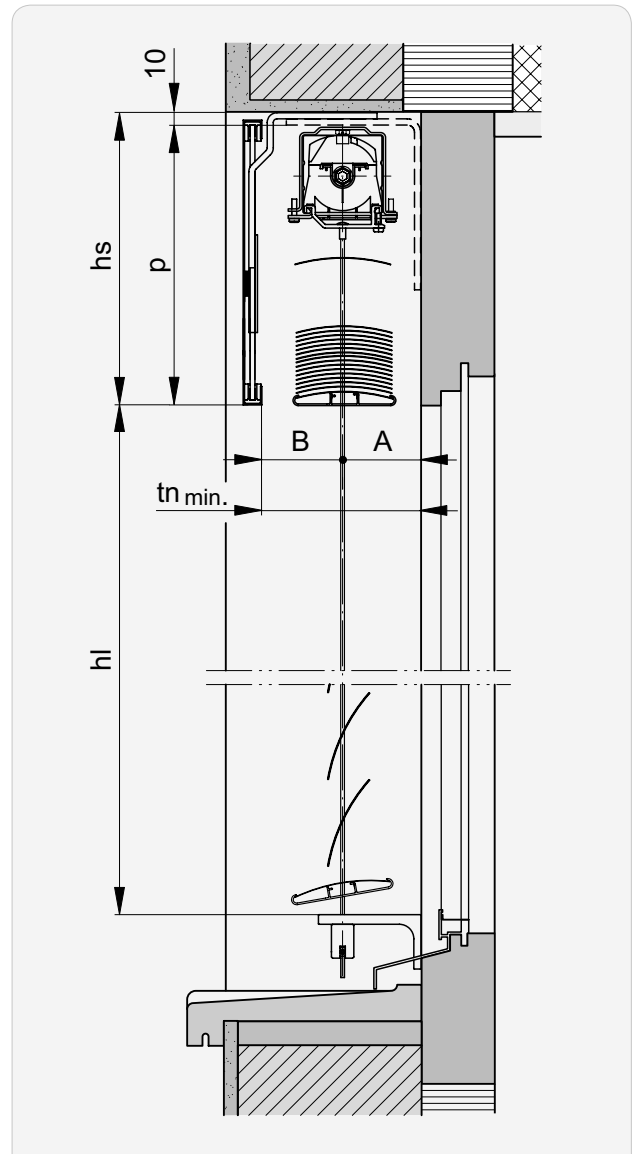

Horizontal section: Guide rail Fix

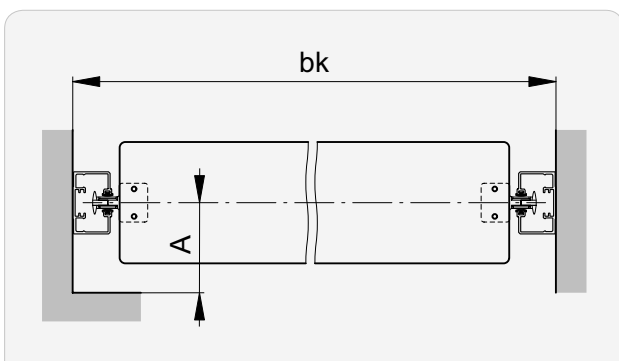

Horizontal section: Cable guide

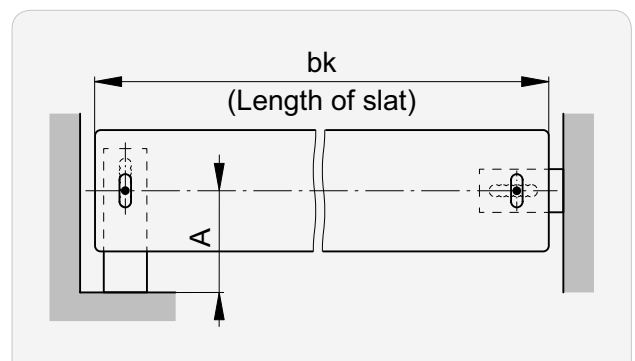

Installation system with Box

Vertical section: Guide rail conventional

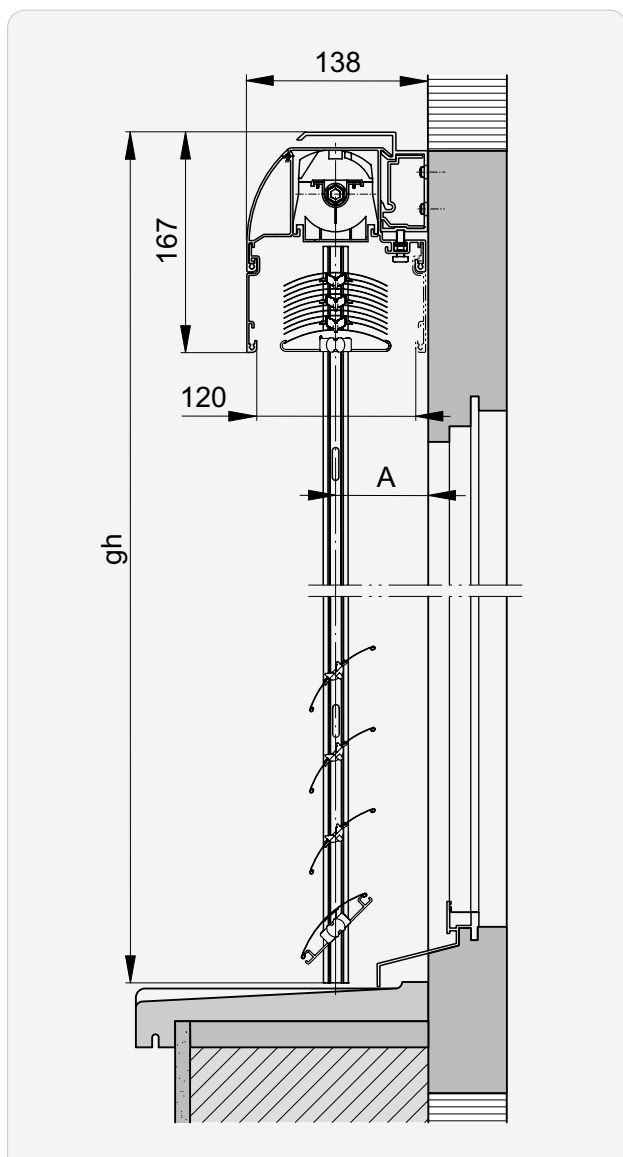

Vertical section: Cable guide

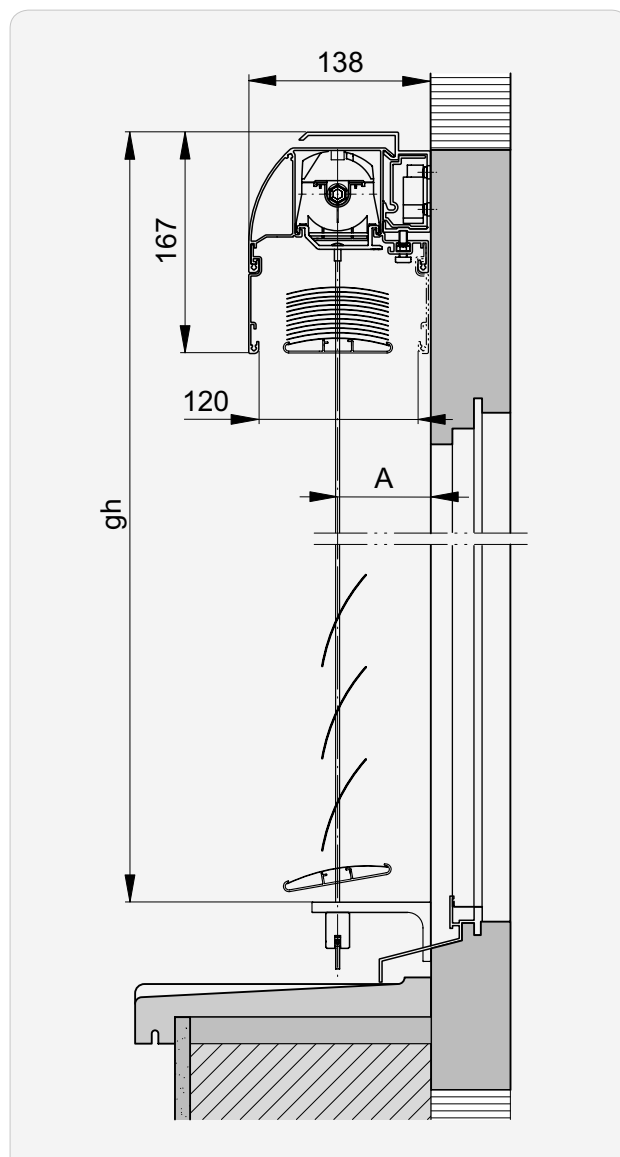

Horizontal section: Guide rail conventional

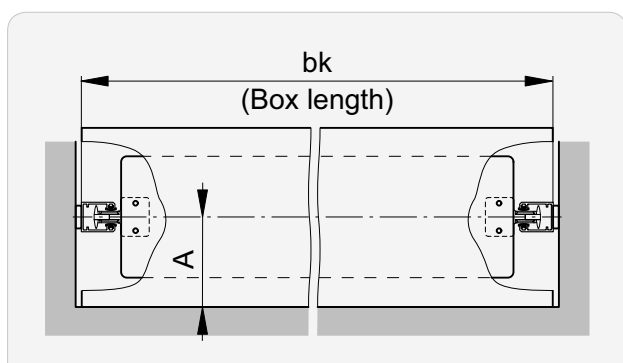

Horizontal section: Cable guide

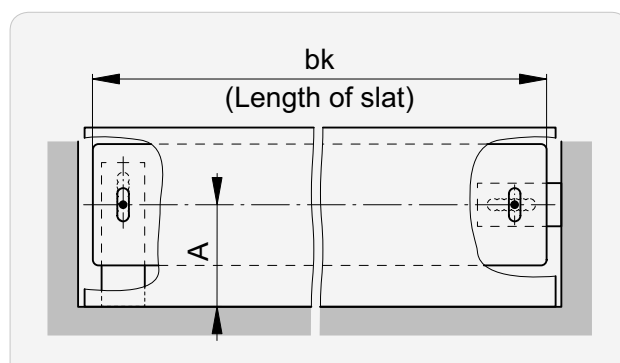

►► Installation system with Box

Vertical section: Box square

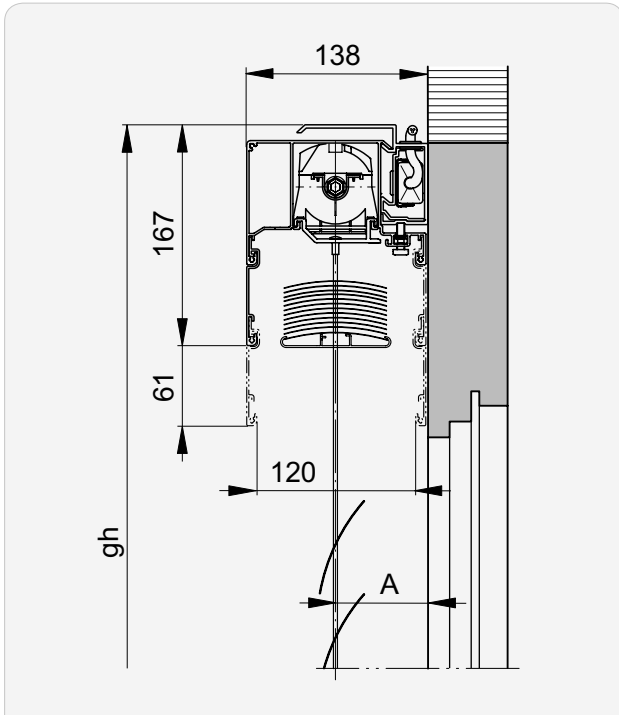

➡ Value for A 187

Box extensions and package projection

Aluflex® Box 60

Height (gh)	Number of extensions	Height (gh)	Projection *	Height (gh)	Projection *
700 ... 1100	1	2501 ... 2600	5	3501 ... 3600	55
1101 ... 2500	2	2601 ... 2700	10	3601 ... 3700	60
		2701 ... 2800	15	3701 ... 3800	65
		2801 ... 2900	20	3801 ... 3900	70
		2901 ... 3000	25	3901 ... 4000	75
		3001 ... 3100	30	4001 ... 4100	80
		3101 ... 3200	35	4101 ... 4200	85
		3201 ... 3300	40	4201 ... 4300	90
		3301 ... 3400	45	4301 ... 4400	95
		3401 ... 3500	50	4401 ... 4500	100

Aluflex® Box 80

Height (gh)	Number of extensions	Height (gh)	Projection *	Height (gh)	Projection *
700 ... 1800	1	4101 ... 4200	2	4301 ... 4400	8
1801 ... 4100	2	4201 ... 2300	5	4401 ... 4500	11

* Slat package not covered (package projection)

Header dimensions | Heights of package

Aluflex® 60

hl →l	P min.	hs ¹	hl →l	P min.	hs ¹
600	146	160	2600	234	255
700	150	165	2700	239	260
800	155	170	2800	243	265
900	159	175	2900	247	270
1000	164	180	3000	252	275
1100	168	185	3100	256	280
1200	173	190	3200	261	285
1300	177	195	3300	265	290
1400	181	200	3400	269	295
1500	186	205	3500	274	300
1600	190	210	3600	278	305
1700	195	215	3700	283	310
1800	199	220	3800	287	315
1900	203	225	3900	291	320
2000	208	230	4000	295	325
2100	212	235	4100	300	330
2200	217	240	4200	305	335
2300	221	245	4300	309	
2400	225	250	4400	313	
2500	230		4500	318	

Aluflex® 80

hl →l	P min.	hs ¹	hl →l	P min.	hs ¹
600	135		2600	190	205
700	138		2700	193	210
800	140	160	2800	196	215
900	143		2900	199	220
1000	146		3000	201	225
1100	149		3100	204	230
1200	151	165	3200	207	235
1300	154		3300	210	240
1400	157	170	3400	213	245
1500	160		3500	215	250
1600	163	175	3600	218	255
1700	165		3700	221	
1800	168	180	3800	224	
1900	171		3900	226	
2000	174	185	4000	229	
2100	176		4100	232	
2200	179	190	4200	235	
2300	182	195	4300	238	
2400	185		4400	240	
2500	188	200	4500	243	

Version	tn min.	A	B
Built-in system	100*	50	50
Installation system (Box)		70	

Version	tn min.	A	B
Built-in system	120*	60	60
Installation system (Box)		70	

¹ If **surface area > 12m²** or **bk > 4000**, the **end rail type 20 (reinforced)** is required. Then **hs = hs + 10**.

With gearbox in slat area: **hs + 20**.

For both box versions: **hs = hs + 7**.

* + possible addition for protruding weatherboard or doorknobs.

Valid for installation of Aluflex® conventional and Fix and also Aluflex® with tensioning cable guide.

i Header dimensions are approximate values which may exhibit **negative or positive deviations** depending on the technical circumstances. **A dimensional tolerance of ±5 mm** is observed for the header height.

Slat profiles

Aluflex® 60

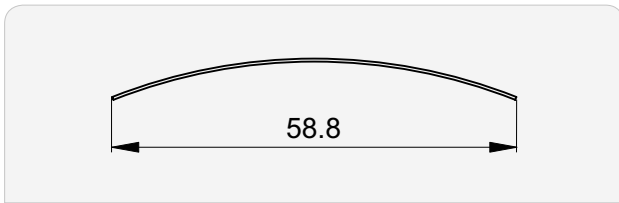

Aluflex® 80

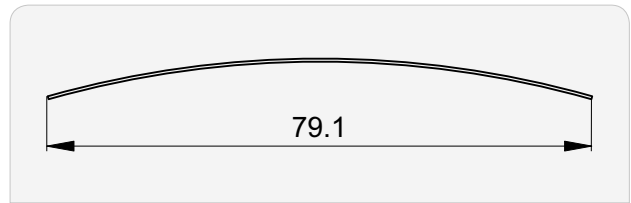

End rails

Aluflex® 60

Type 10

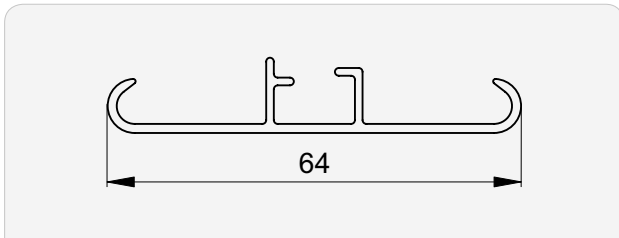

Aluflex® 80

Type 10

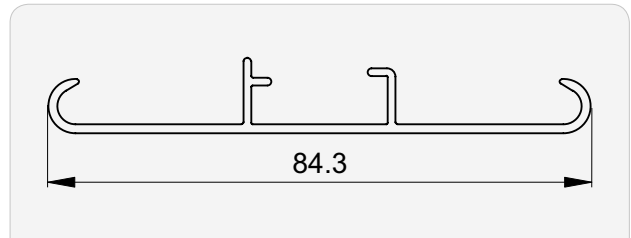

Type 20 (reinforced)

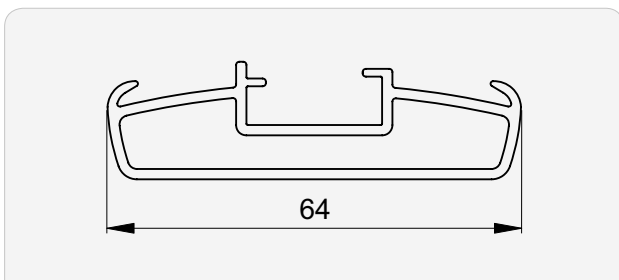

Type 20 (reinforced)

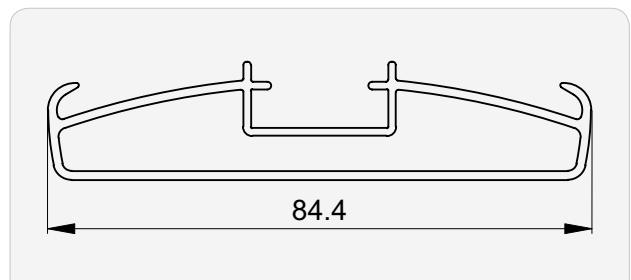

i If surface area > 12 m² or bk > 4000, the end rail type 20 (reinforced) is required.

Beginning distance | Slot spacing

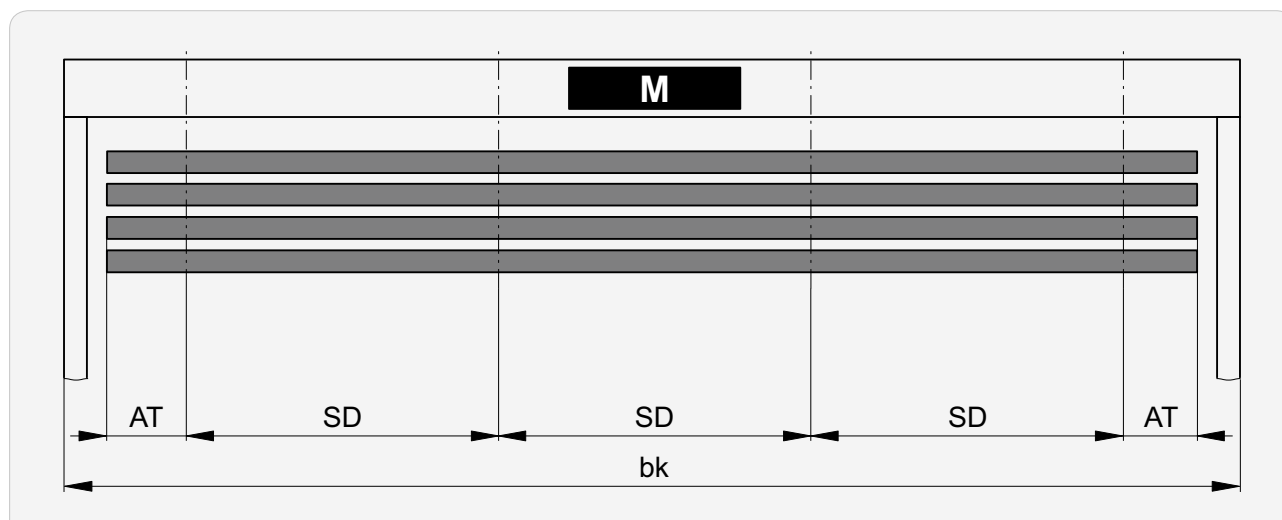

bk	AT min.		SD min.	SD max.
≤ 610	Conventional	50		
	Fix	60		
	Fix connected	80		
	Cable	67		
611 ... 1250	Conventional			
	Fix	100	250*	1000*
	Fix connected			
	Cable	117		
> 1250	Conventional			
	Fix	200		
	Fix connected			
	Cable	217		

* Standard slot spacing machine fabrication

Deviations from the standard are possible when:

Deviation	Correction
MBMA+ < 40	AT
Support loading too high	AS
Slot spacing < 250	AT + AS
With motor	AT + AS

AT Beginning distance
Distance from beginning of slat to centre of bearing

SD Slot spacing
Distance from centre of bearing (slot) to centre of bearing (slot)

Housing fastening

At top

NO

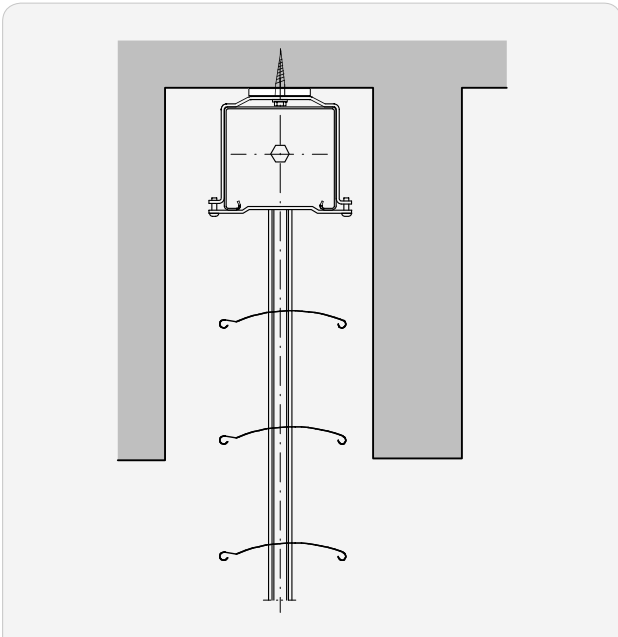

Box support

KT

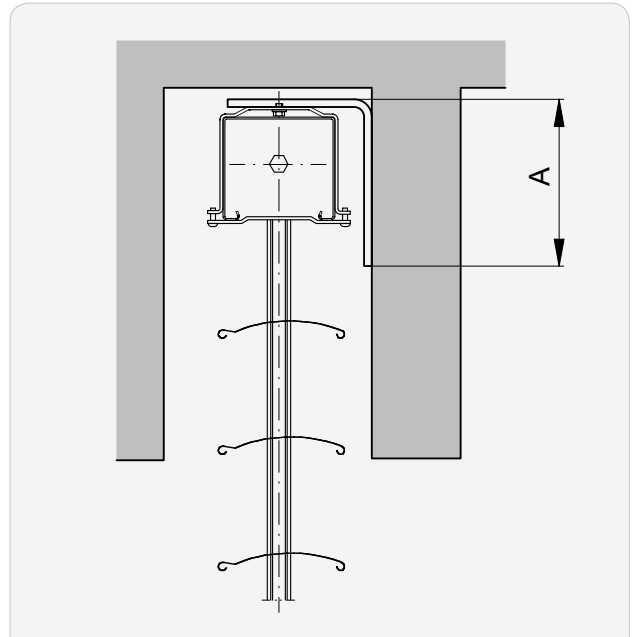

Box support for type KT, for small headers*

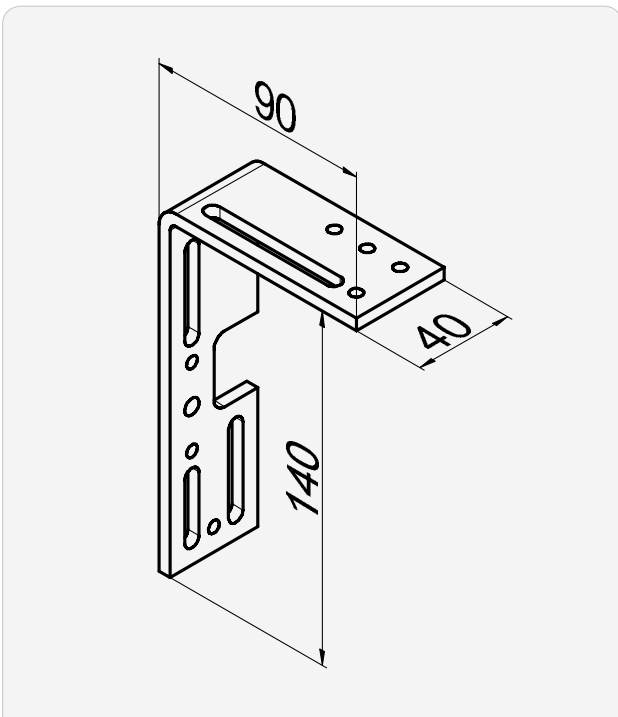

A
140

* Header 100

Box support for type KT

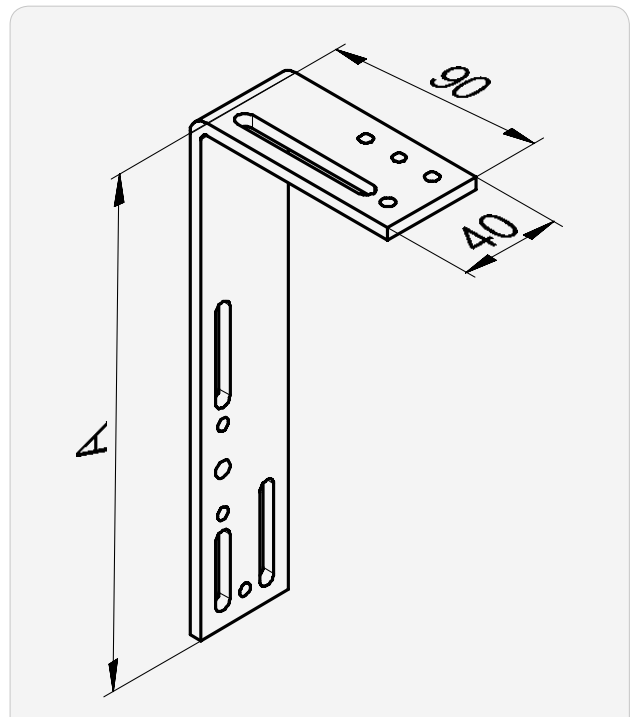

A
200
260

►► Housing fastening

Double box support

DR

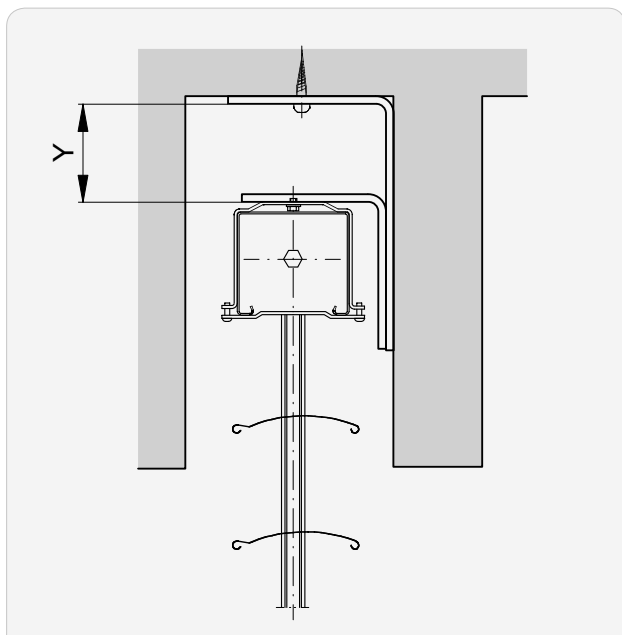

Gallery clip

GB

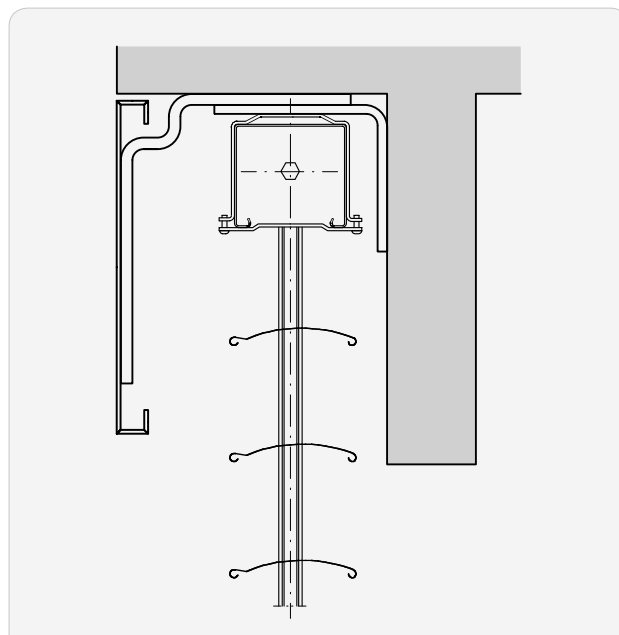

Double box support for type DR

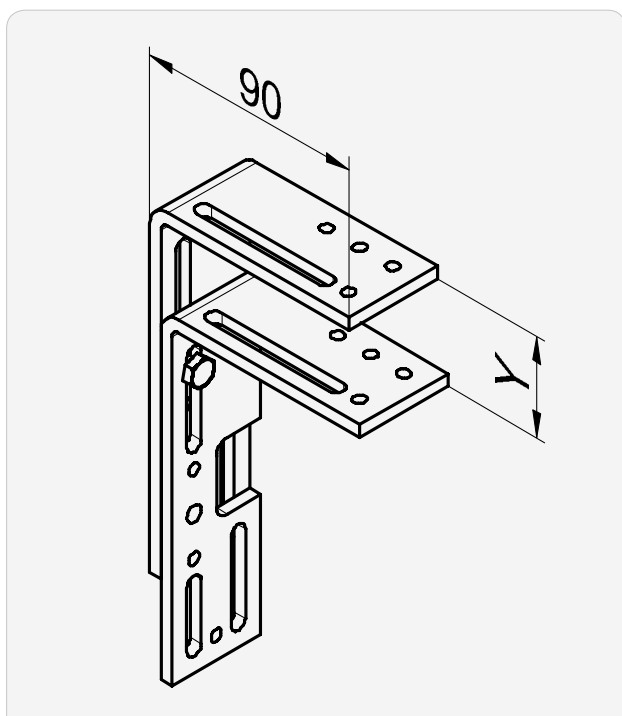

Gallery clip for type GB

i See additional documentation:
Short manual "Covers"



[↓ Covers](#)



Y

 10... 75

 75... 135

 135... 200

Number of box supports**Conventional and cable guides**

bk	Quantity
≤ 2000	2
2001 ... 3000	3
3001 ... 4000	4
> 4000	5

Fix guides | Additional fastenings

bk	Quantity
≤ 2500	0
2501 ... 3500	1
> 3500	2

Fixation for box base profile

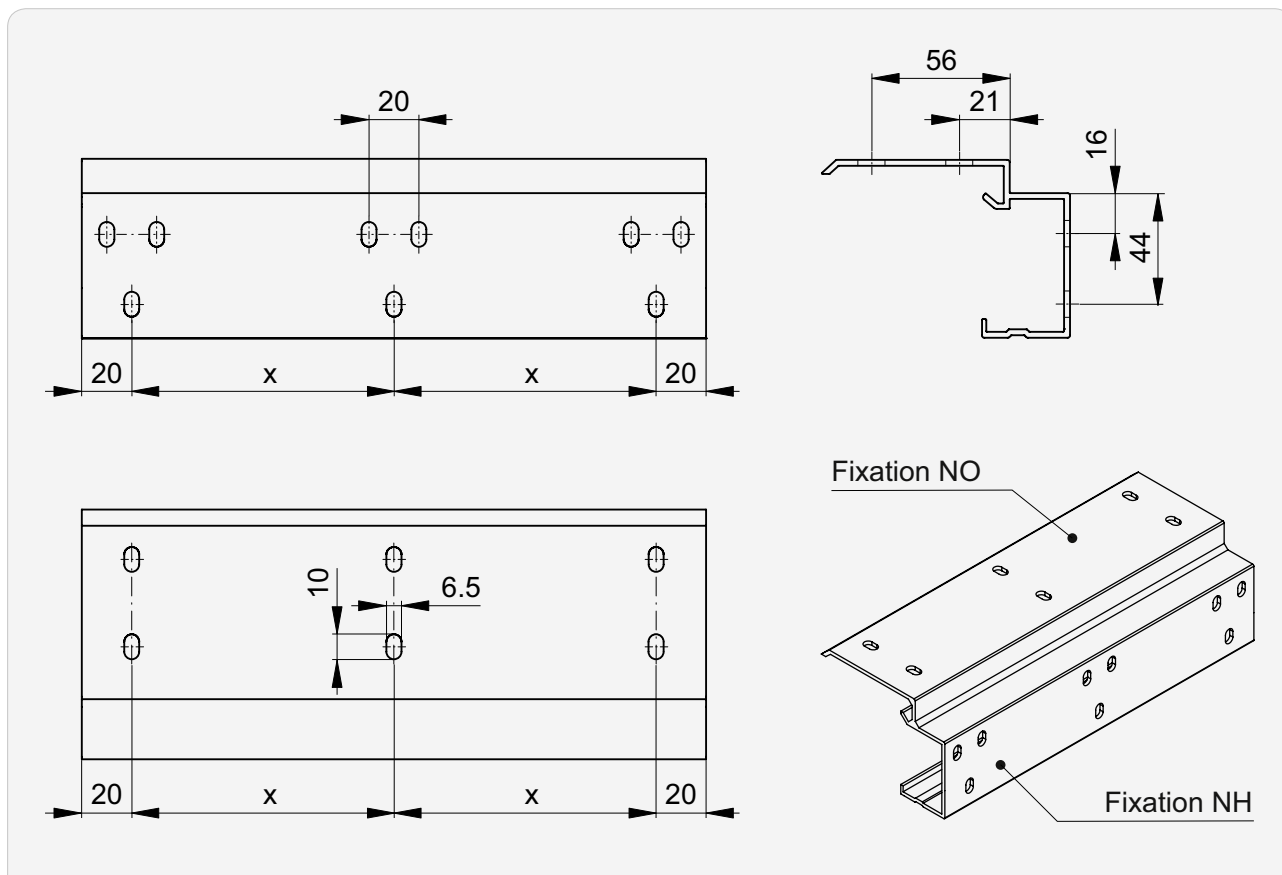

Number of fixation points

bk	Number of fixation points
≤ 2000	2
2001 ... 3000	3
3001 ... 4000	4
> 4000	5

Technical data of motors

Performance characteristics

Type	Limit switch		M [Nm]	n [1/min.]	P [W]	I [A]	
	Type	Number of					
Standard							
Elero							
ES...	06.01	mechanical	6	26	110	0.50	
	09.01		9		170	0.75	
EO...	20.01		20		190	1.05	
ES...	06.51	mechanical	6	26	110	0.50	
	09.51		3		9	170	0.75
EO...	20.51		20		190	1.05	
Option							
Somfy							
SH...	06.01	mechanical	6	24	95	0.40	
	10.01		2		10	110	0.65
	18.01				18	155	1.00
SW...	06.01		6		95	0.40	
SI...	10.01	electronic	10	24	110	0.65	
	18.01				18	155	1.00
Elero Comfort							
ECM...	06.01	electronic	6	26	115	0.50	
	09.01		2		9	156	0.68
	06.51		3		6	115	0.50
	09.51				9	156	0.68
ECB...	06.01	electronic	6	26	115	0.50	
	09.01		2		9	156	0.68
	06.51		3		6	115	0.50
	09.51				9	156	0.68
Geiger AIR							
GA...	06.01	electronic	6	26	93	0.40	
	06.10		2		10	135	0.60
	06.20				20	190	0.85

I Current consumption

M Torque

n Rotational speed

P Power consumption

Options

Feedthroughs with eyelets

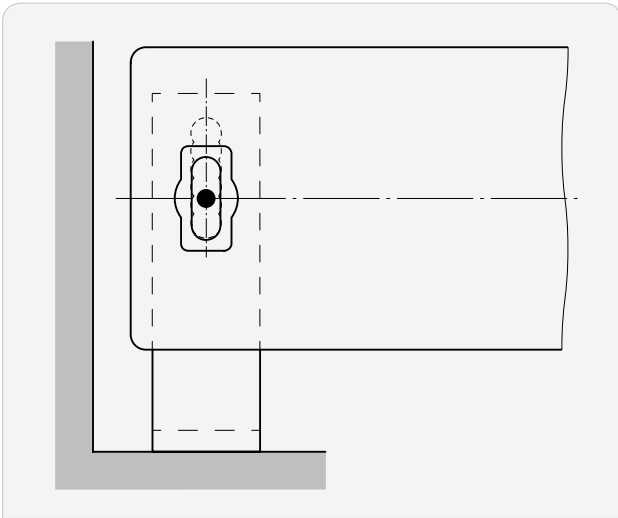

Guide rails

Type E | Single guide

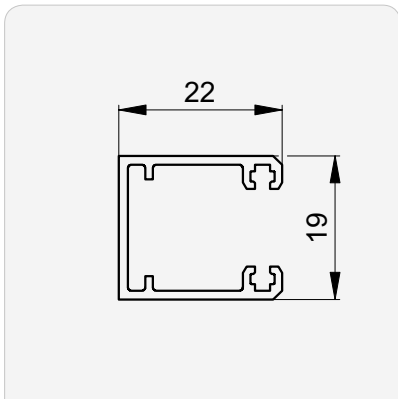

Type L | Fix guide

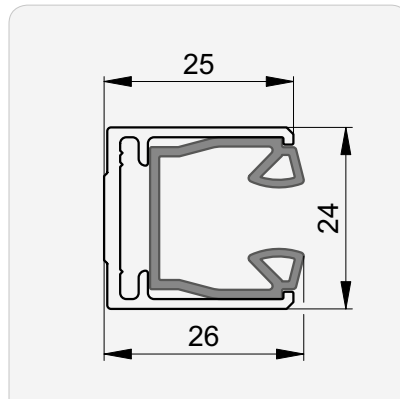

Type F | Fix guide

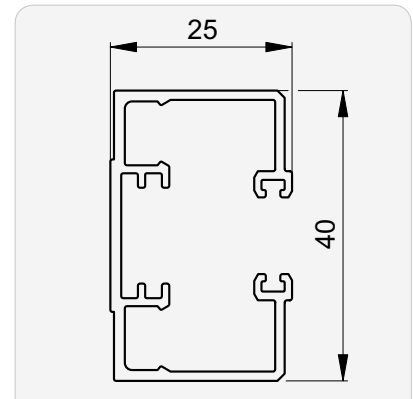

Type D | Double guide

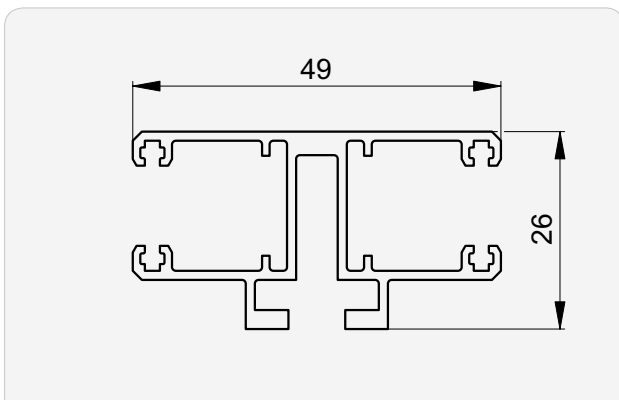

Special guide fastening required

Type C | Single guide

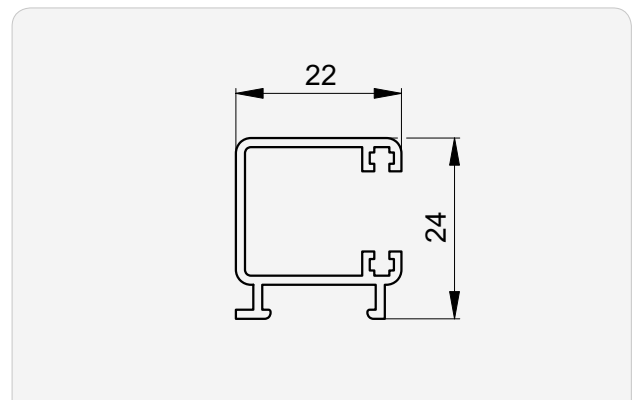

Type R | Curved double guide

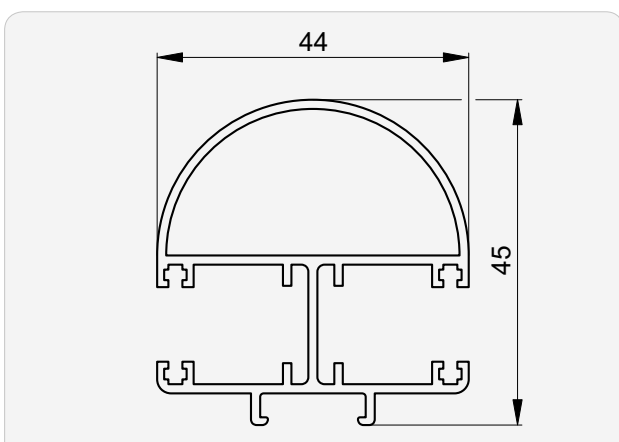

Type T | Double guide

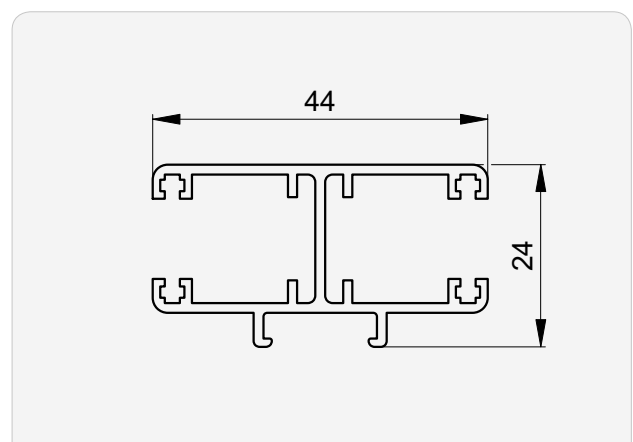

➔ Distance between guides FD	225	➔ Guide rail cut-outs in windowsill area.....	218
➔ Fastening points.....	221	➔ Installation window.....	220
➔ Guide extension and facet.....	215	➔ Integrated guides.....	206
➔ Guide rail fastenings.....	207		

Sections | Details

Horizontal section: Guide rail conventional

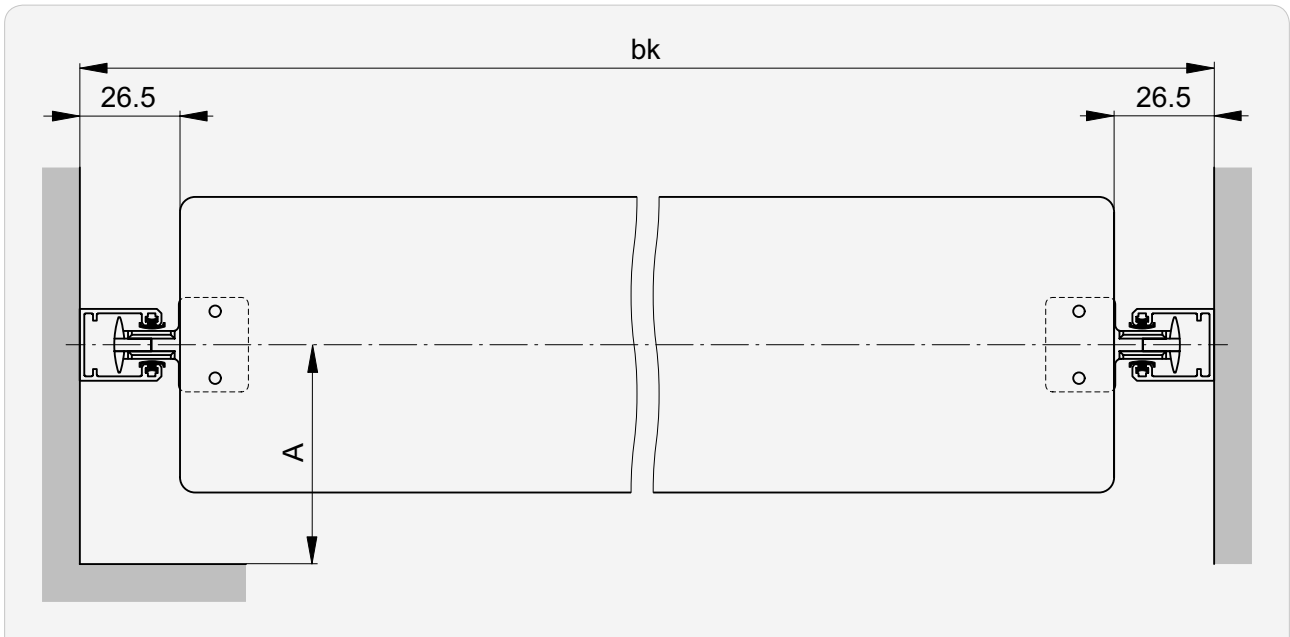

Horizontal section: Guide rail Fix-L

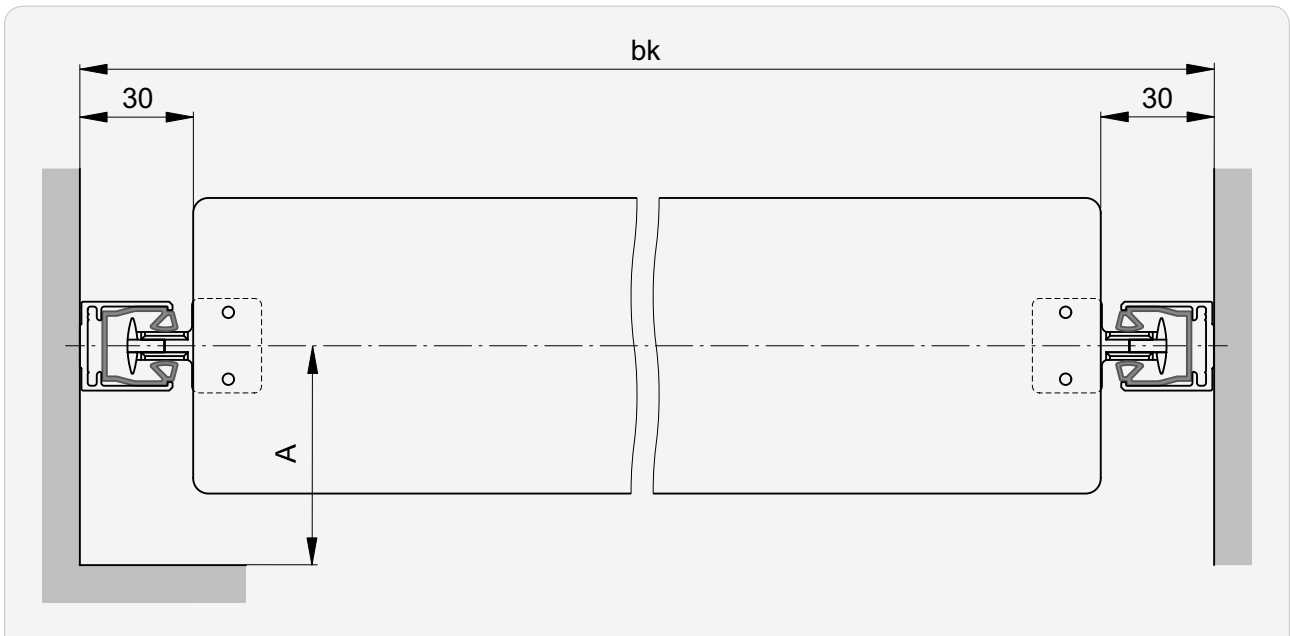

➡ Value for A 187

►► Sections | Details

Horizontal section: Guide rail Fix

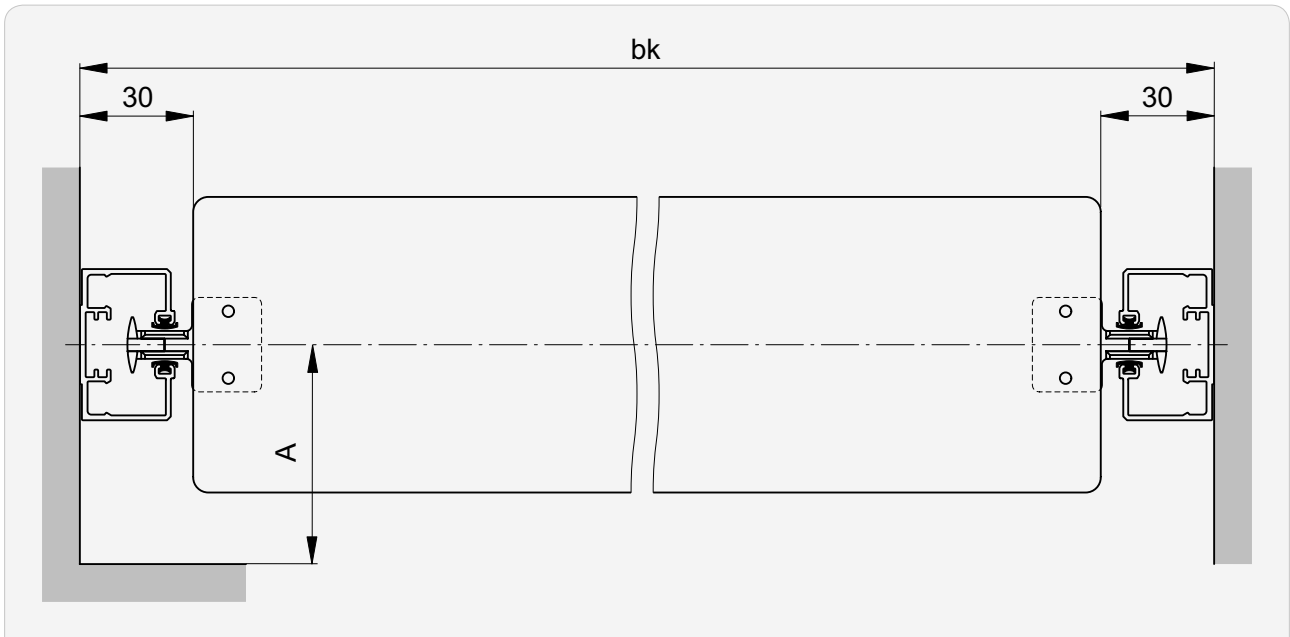

Horizontal section: Box

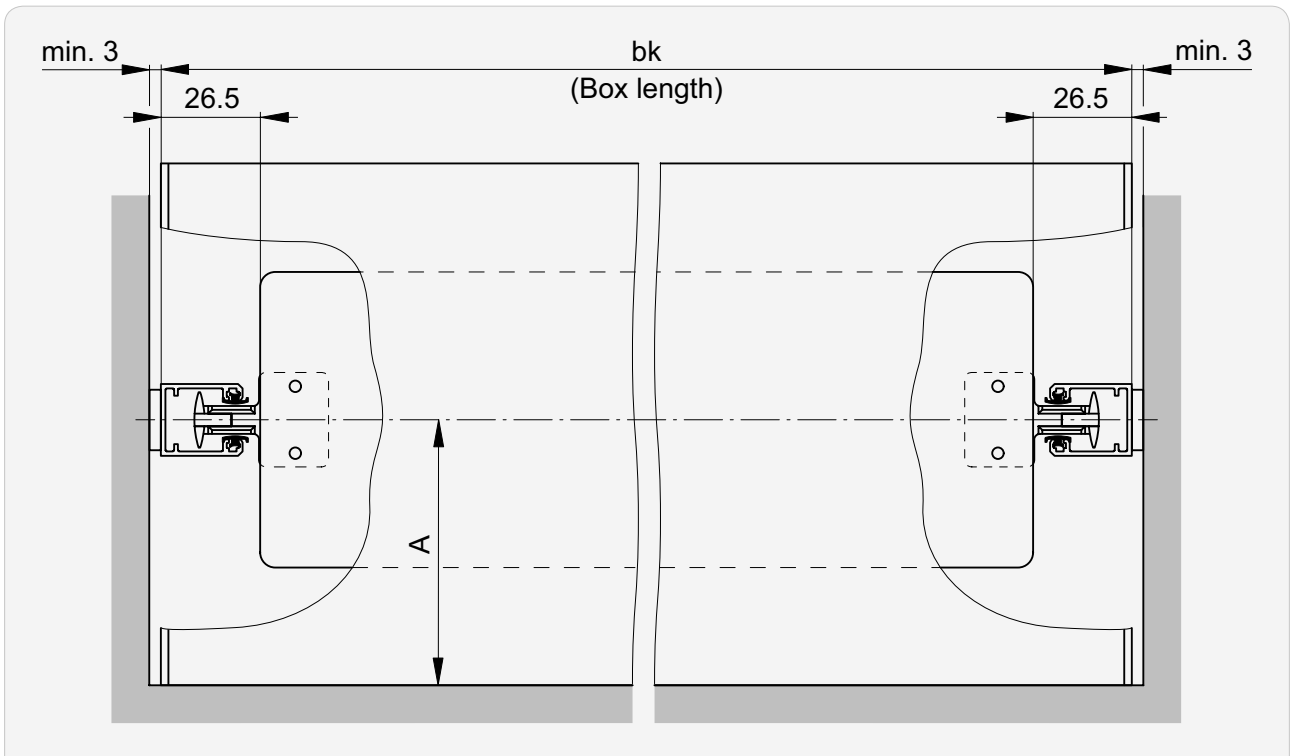

➡ Value for A 187

►► Sections | Details

Detail at bottom

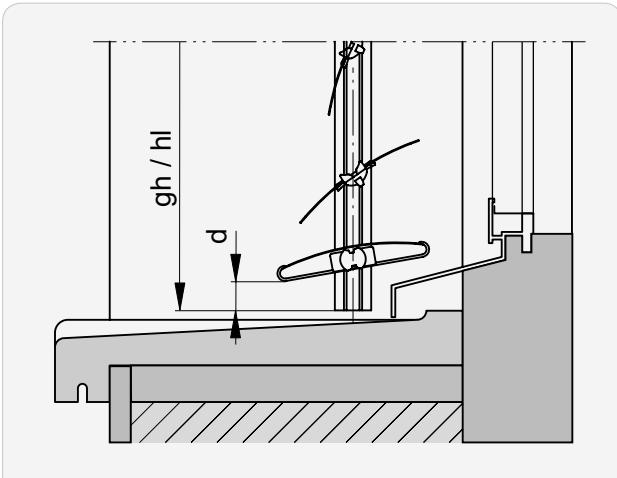
**d (d-dimension)**

min. 10 +5/-3

i **d-dimension** may vary with different blind dimensions.

Sections for crank drive (MBMA)

outside bk

Conventional

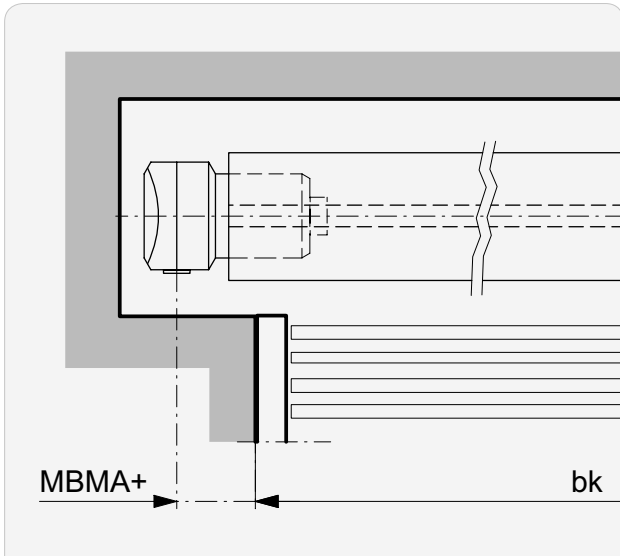

Self-supporting (Fix)

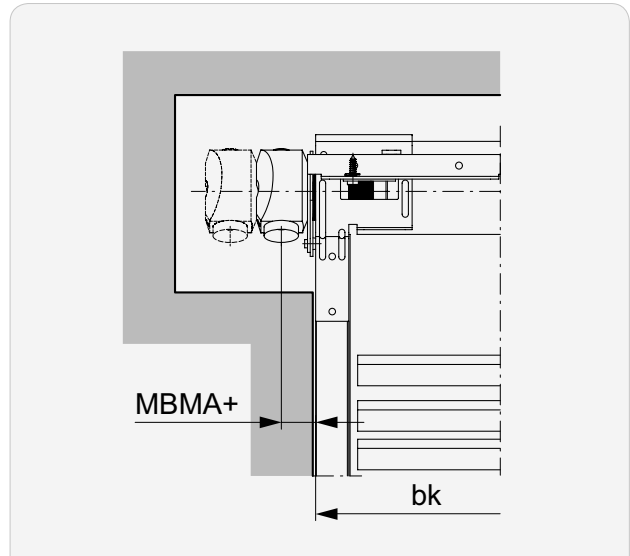

within bk

Conventional

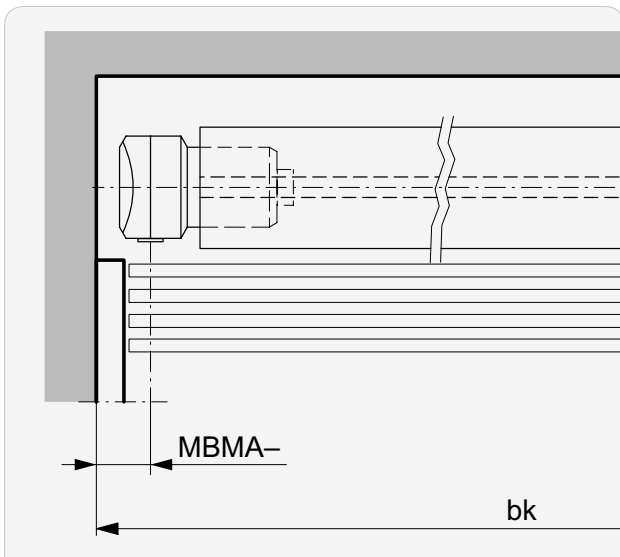

Self-supporting (Fix)

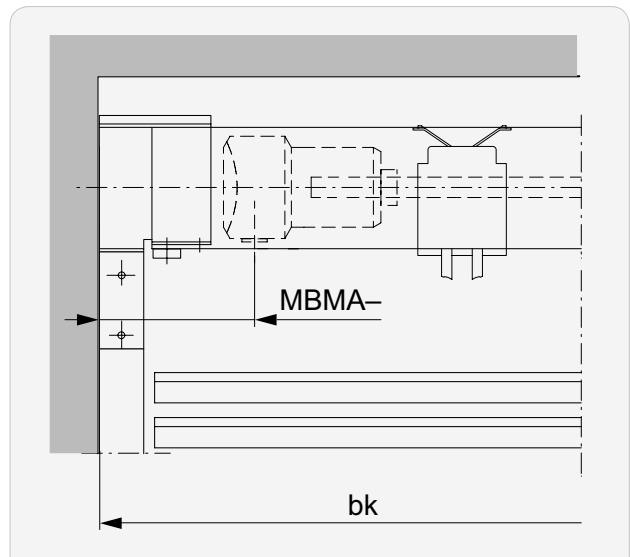

Version	MBMA+	MBMA-
Conventional	0 ... 999	0 ... (bk/2)*
Self-supporting (Fix)	26 ... 125 (10 ... 25) ¹	90 ... (bk/2)

¹ for reverse mounted gearbox

* ≤30: Gearbox niche required

Additional cables

i **Additional cables must be fitted for a $bk > 2500$** and in locations which are exposed to high wind. The dimensions **P1** and **P2** are **measured from the left from bk** and **must be noted on the dimensions sheet**. P2 does not apply for the first additional cable.

If the additional cables **are installed in the windowsill**, you must plan for **an excess guide rail length of min. 60mm**. The **end rail** is then **70mm above the windowsill**.

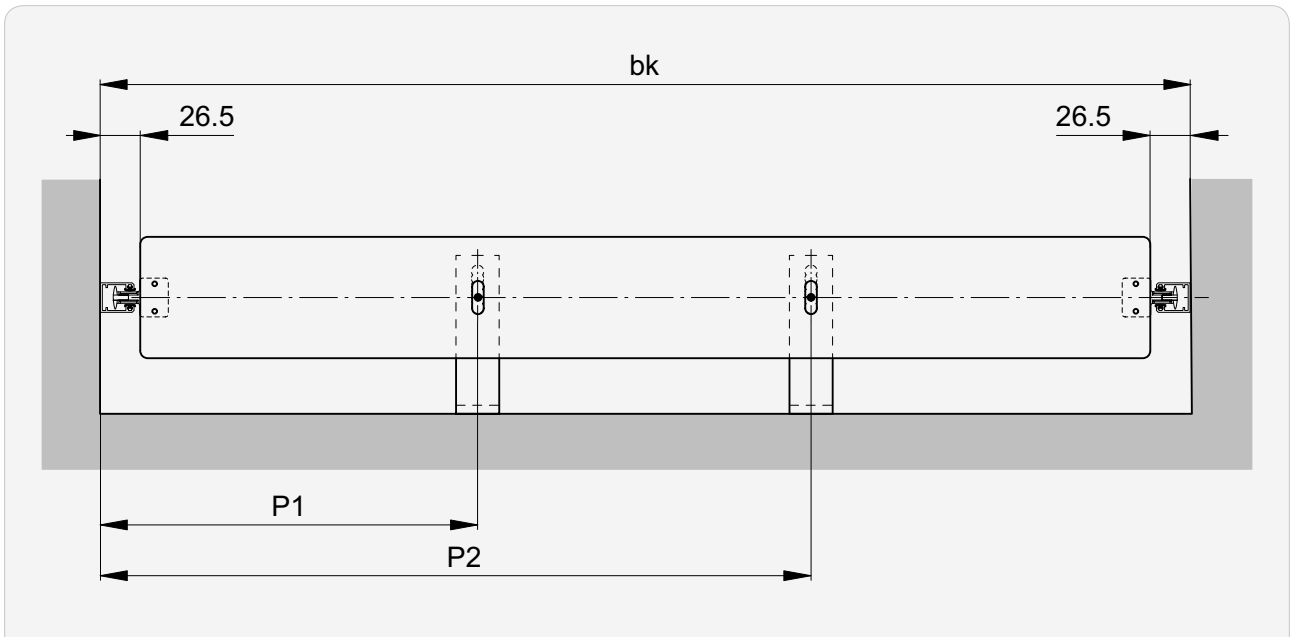

P1 Position of first cable or cable on the left

P2 Position of cable on the right

Number of additional cables

i **If no information is provided for P1 or P2, they are positioned according to the following table.**

Width max. (bk)	Number of additional cables	P1	P2
≤ 2500	0	–	–
2501 ... 3800	1	(bk/2)	–
> 3800	2	(bk/3)	2 (bk/3)

Vertical connections | Standard motor position

Number of bearings

Aluflex® 60

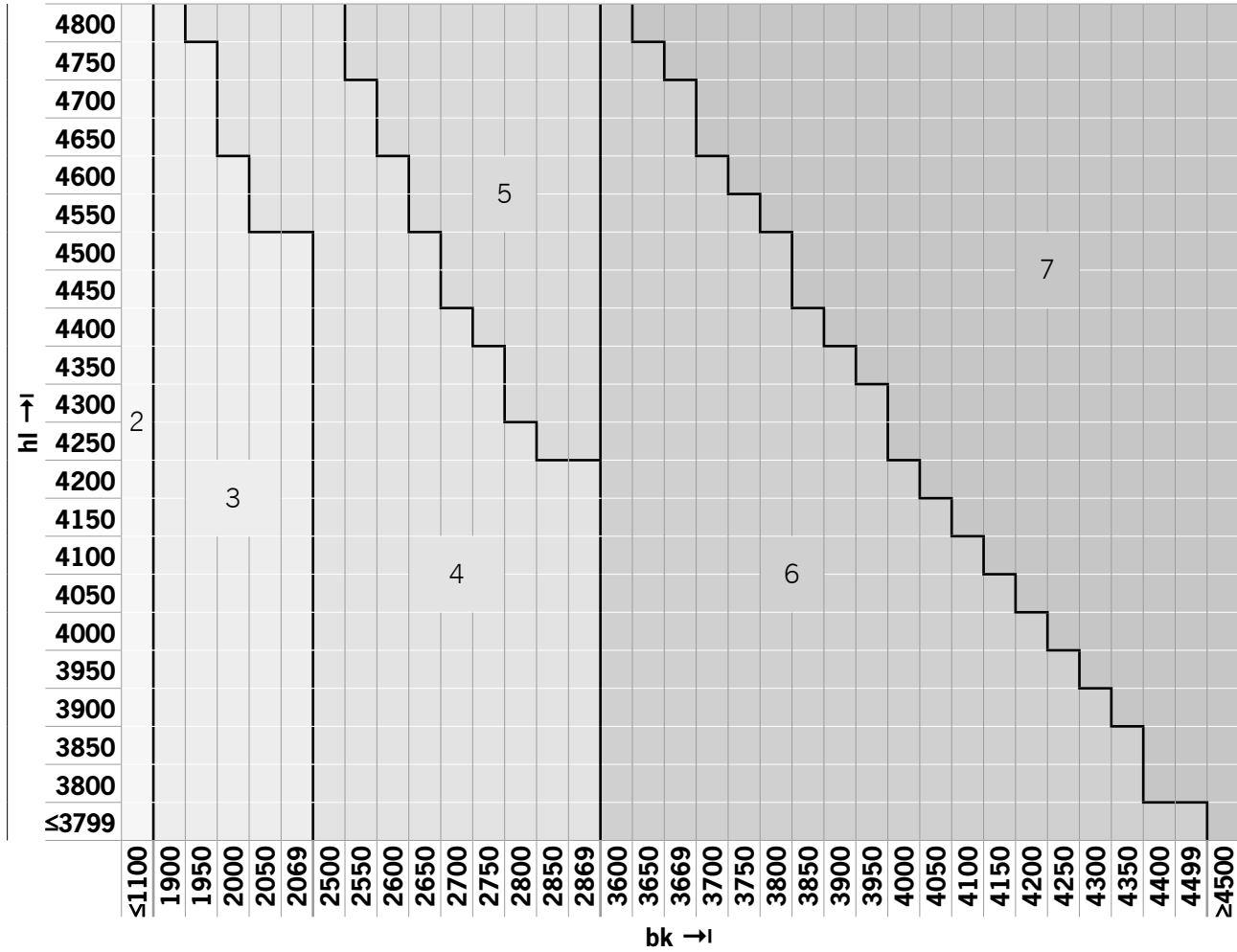

►► Vertical connections | Standard motor position





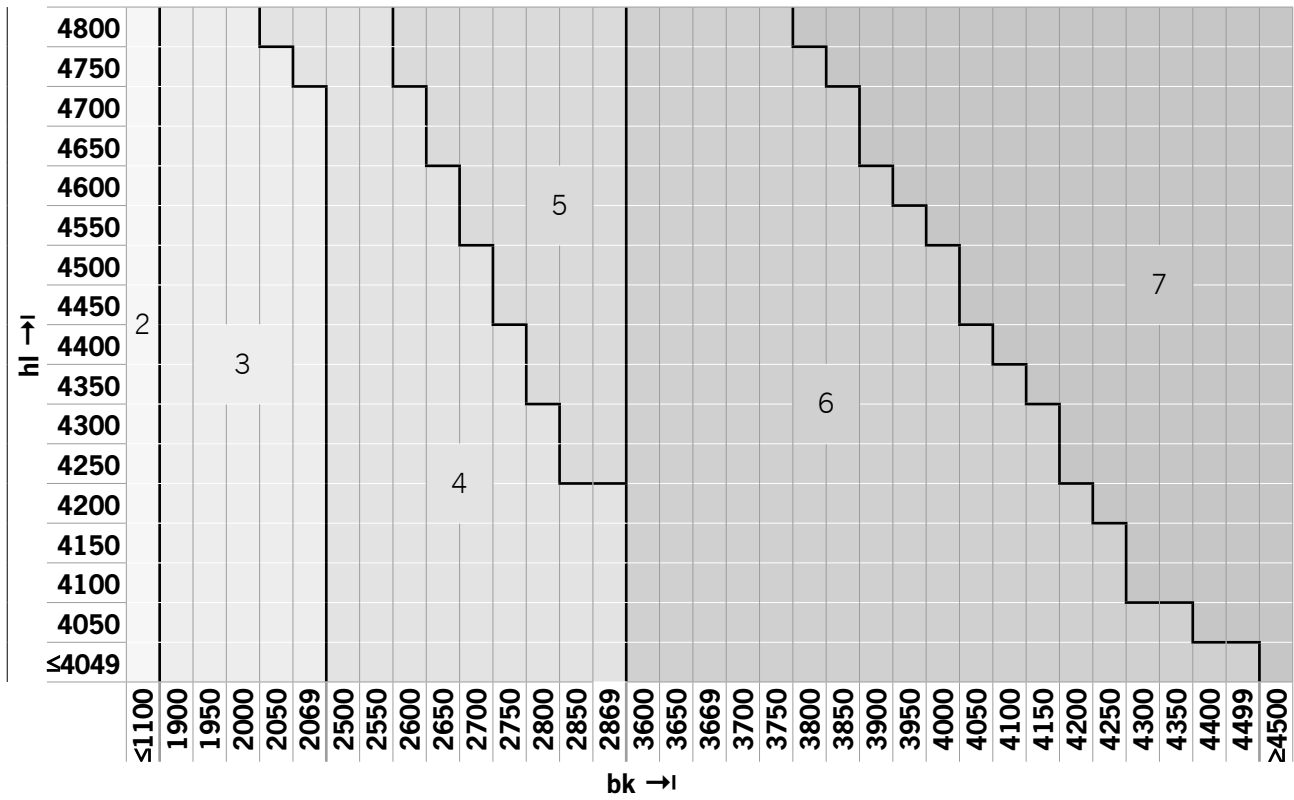

Number of bearings

Aluflex® 80



►► Vertical connections | Standard motor position

Standard motor position

Number of bearings	Standard motor position
2	
3	
4	
5	
6	
7	

- Bearing
- M** Standard motor position
- M Possible motor position (on request)

Guide rail installation (principle)

Guides attached (to soffit) | Type A

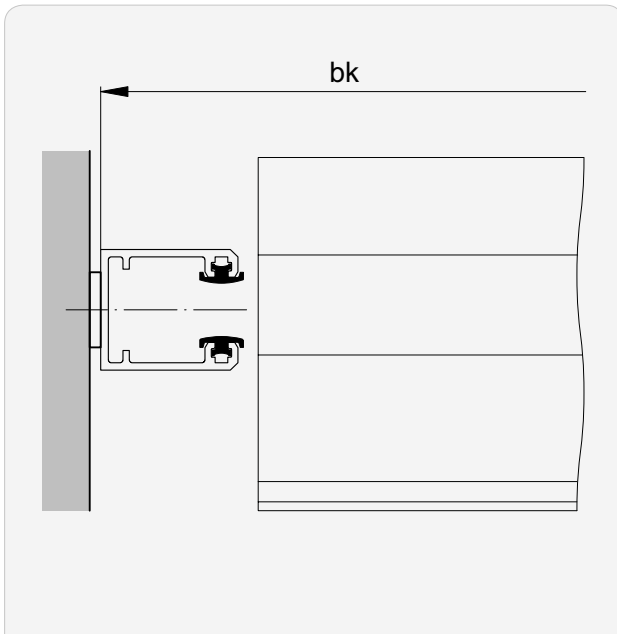

i Observe possible guide rail spacer for **bk**.
Standard: 2 mm

Guides suspended

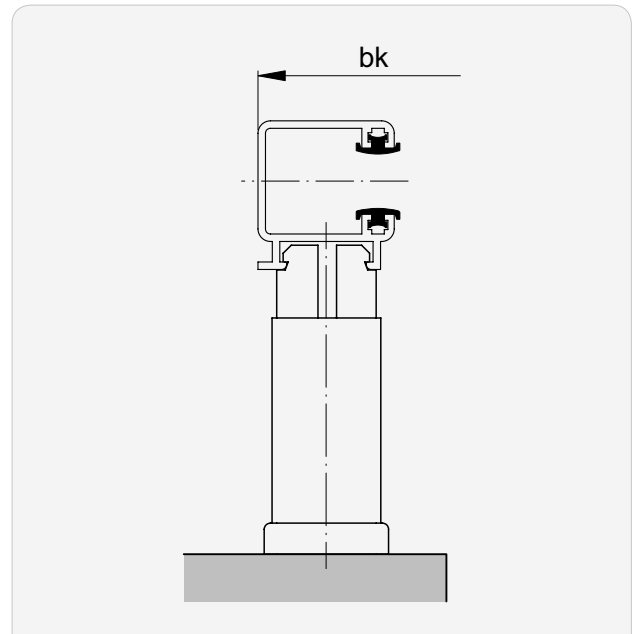

►► Guide rail installation (principle)

Guides recessed

i *Type F | Without guide cut-out:
Only possible if curtain can be retracted from below.

Type E | F* | L

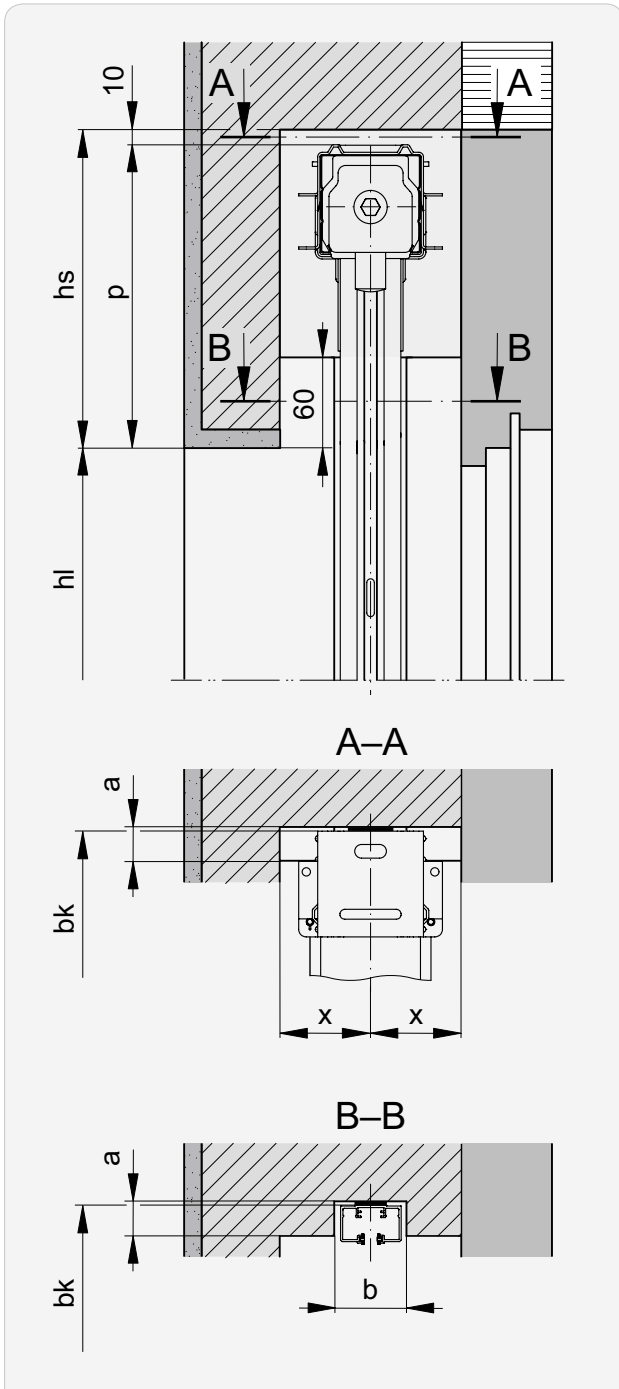

Type E

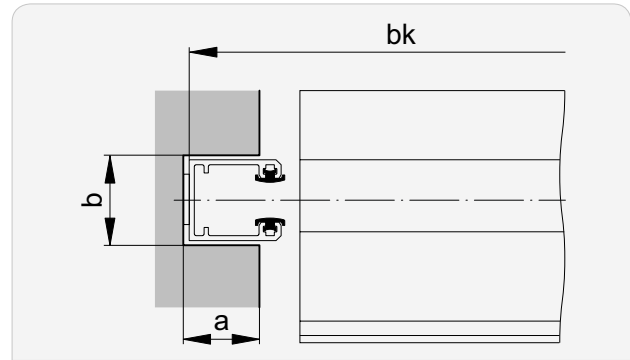

Type F*

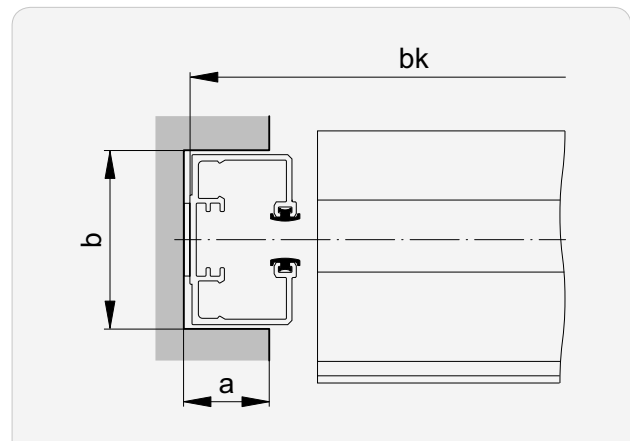

Type L

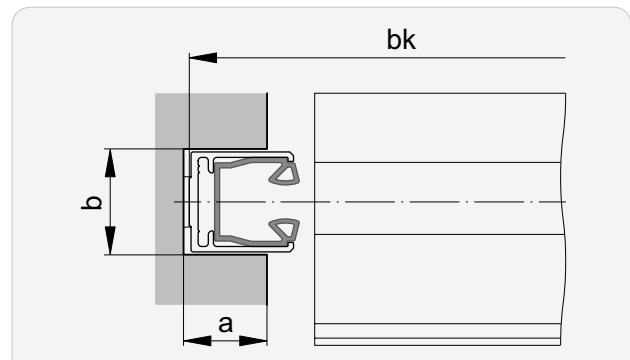

Product Version	x min.
Aluflex® 60 Fix	50
Aluflex® 80 Fix	60

Type	a	b
E	≤18	≥21
F*	≤20	≥42
L	≤24	≥25

Guide rail fastenings (principle)

Overview

														Type
A	B	Bd	C	Cd	E	F	G	H	Kv	M	T	Tv	V	Wv
●	●	●	●	●	●	●	—	○ ¹	○ ²	○ ³	●	●	●	●

- applicable without restrictions
- applicable with restrictions:
 - ¹ only with guide **type D**
 - ² only with guide **type C | T | R**
 - ³ only with guide **type E**

A Soffit installation

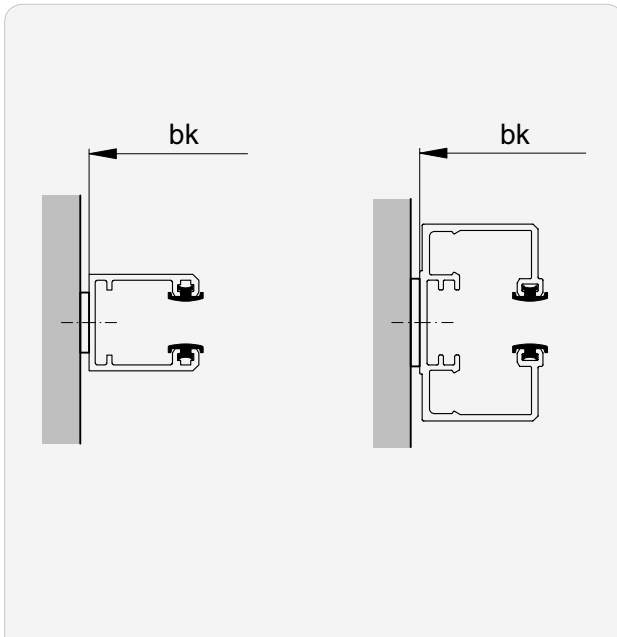

i Observe possible guide rail spacer for **bk**.
Standard: 2 mm

►► Guide rail fastenings (principle)

B Installation with fastening bracket

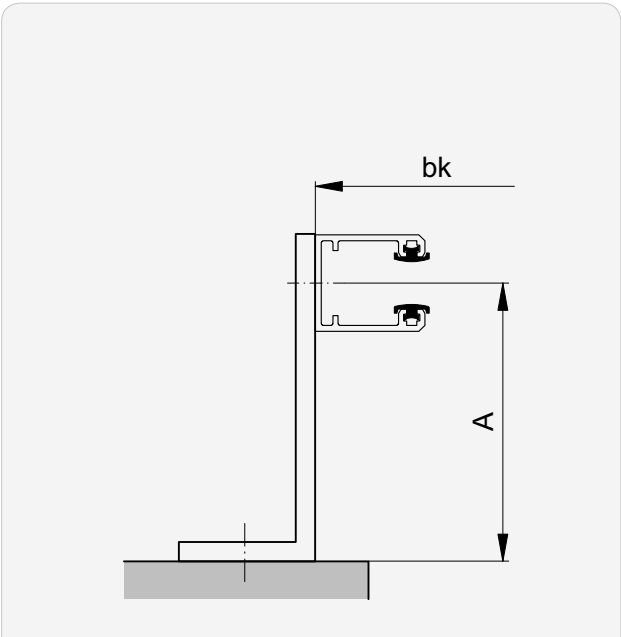

Bracket outwards

C Installation with fastening bracket

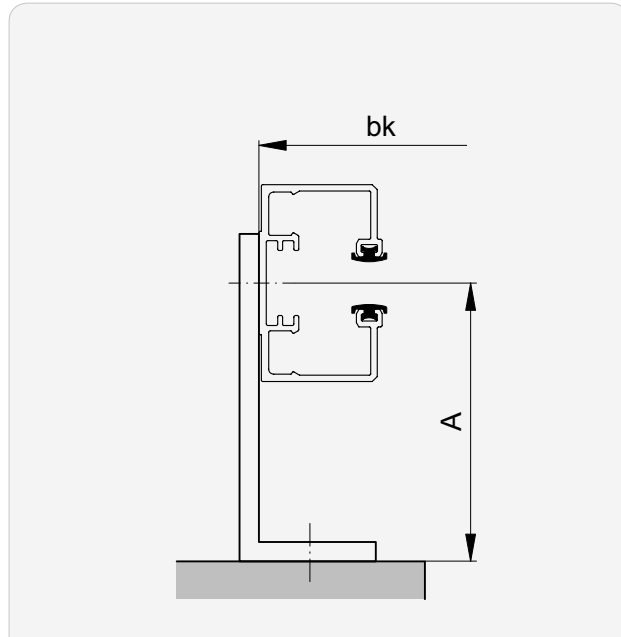

Bracket inwards

Fastening bracket for types B and C

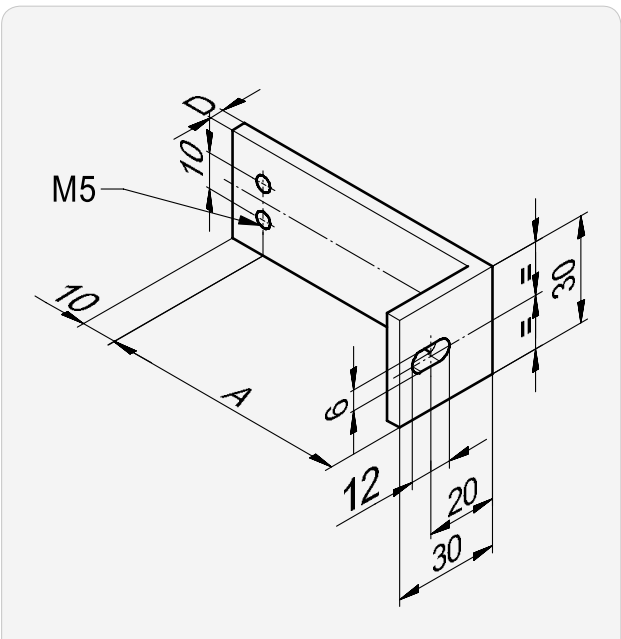

A*	D
20... 115	4

Fastening bracket 70 mm for types B and C

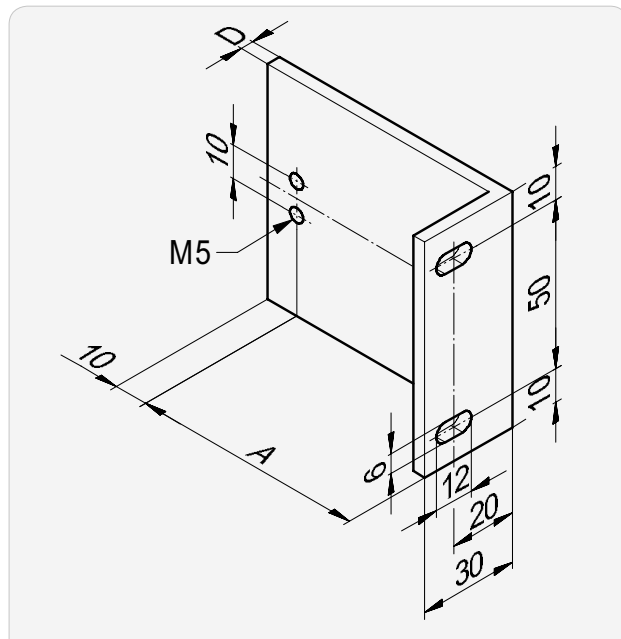

A*	D
20... 115	4
120... 215	5

i For suspended guide rails always with **brackets 70mm.**

i If the **projection is ≥120**, all products are fastened with a **70mm bracket.**

* in 5 mm steps

►► Guide rail fastenings (principle)

Bd Installation with continuous fastening bracket

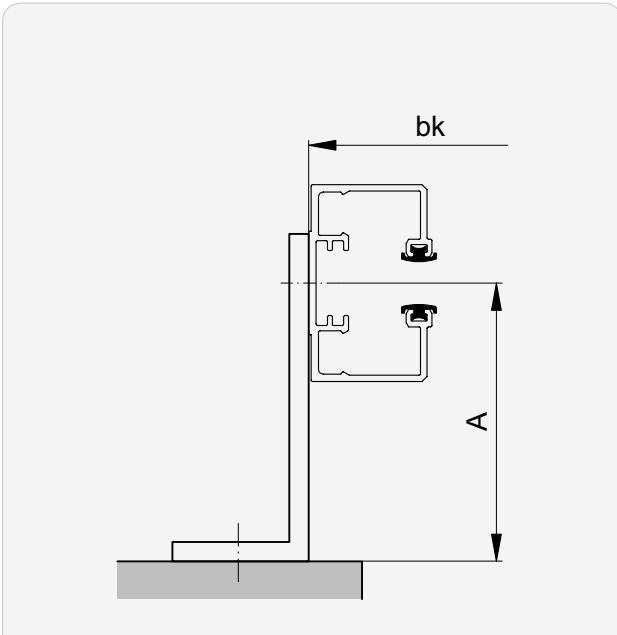

Bracket outwards

Cd Installation with continuous fastening bracket

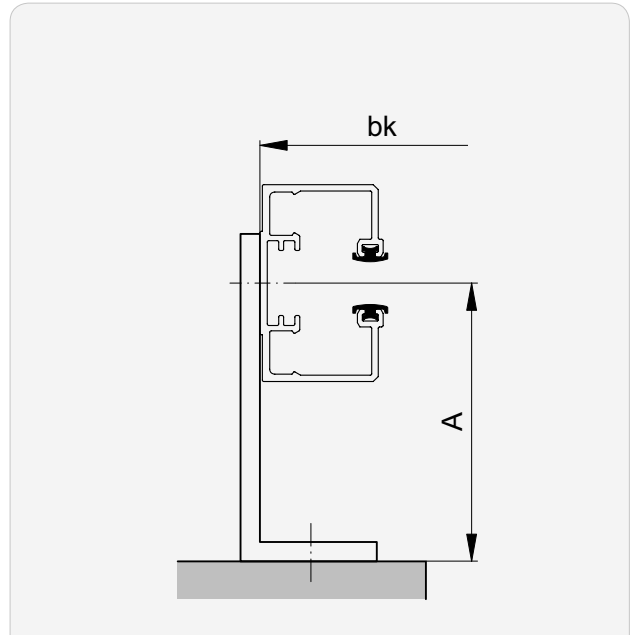

Bracket inwards

Continuous fastening bracket for types Bd and Cd

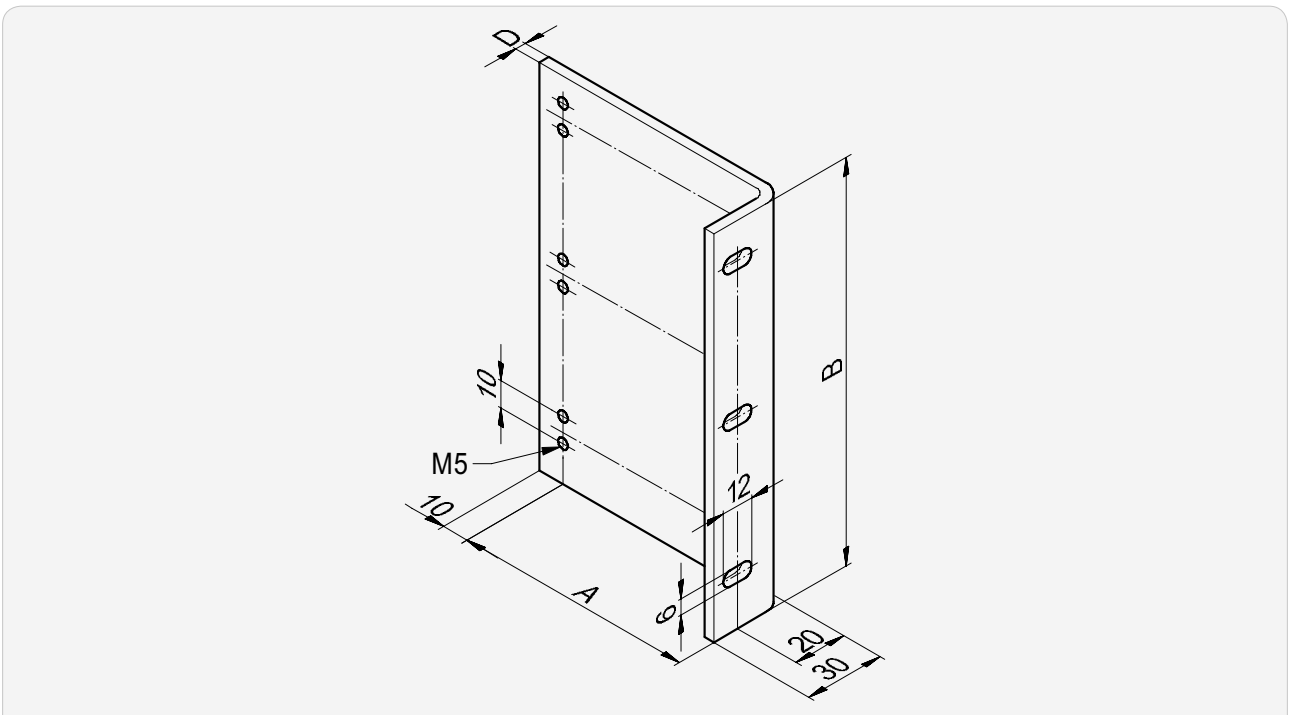

A*
20...300

D
always 4

* in 5 mm steps

►► Guide rail fastenings (principle)

E|F Installation with fastening lug

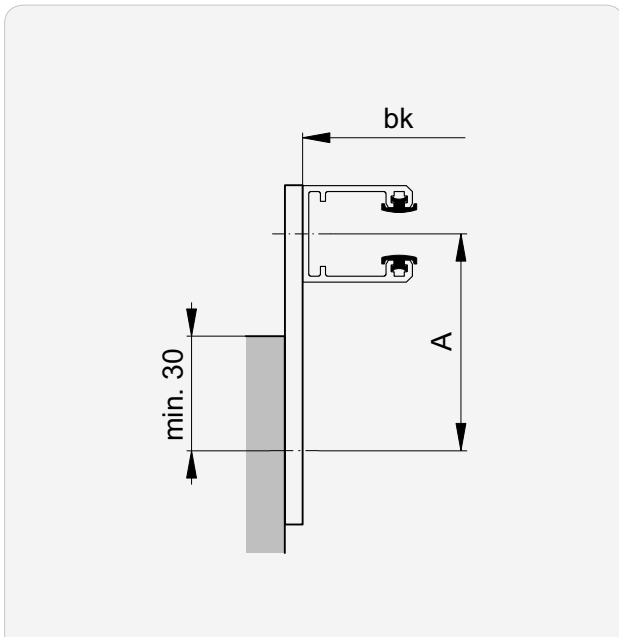

inwards / outwards

Fastening lug for type E | F

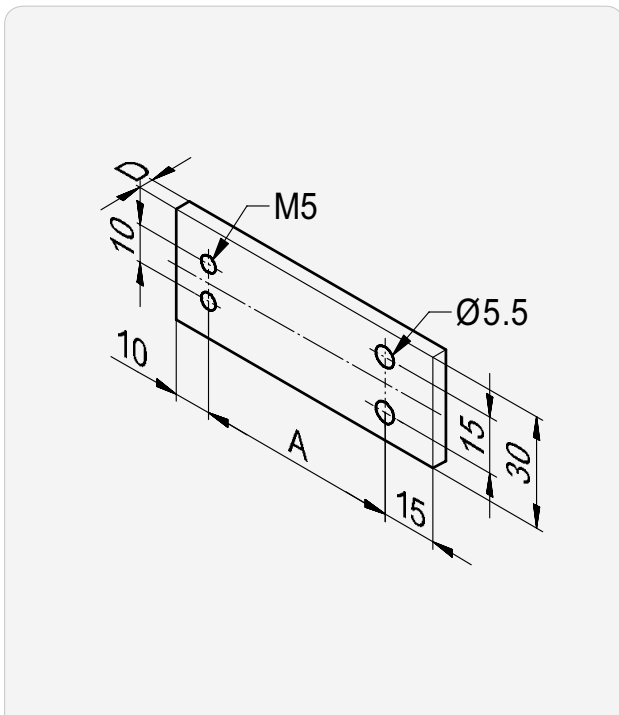

A*	D
50... 115	4
120... 125	5

* in 5 mm steps

H Installation with spacer

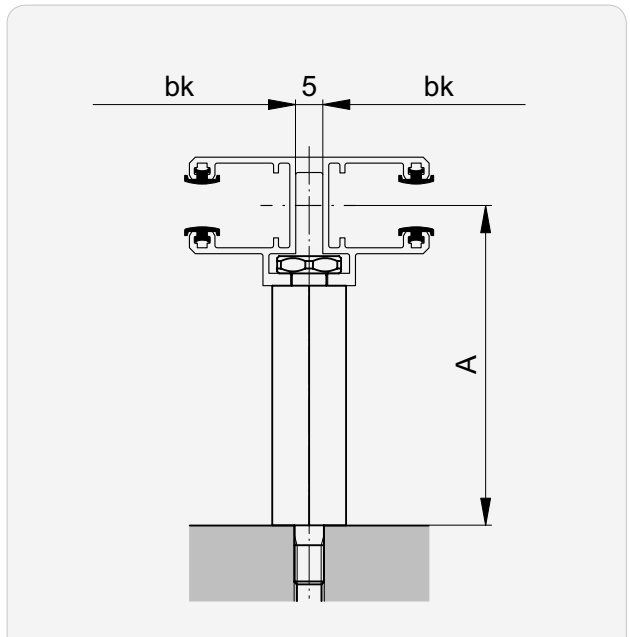

Only with guide type D

Spacer for type H

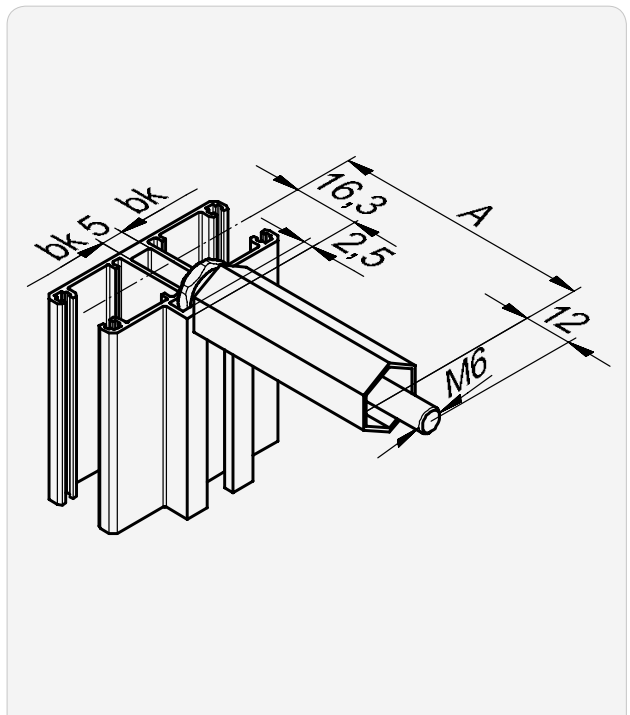

A
35... 115

►► Guide rail fastenings (principle)

Kv Installation with adjustable console

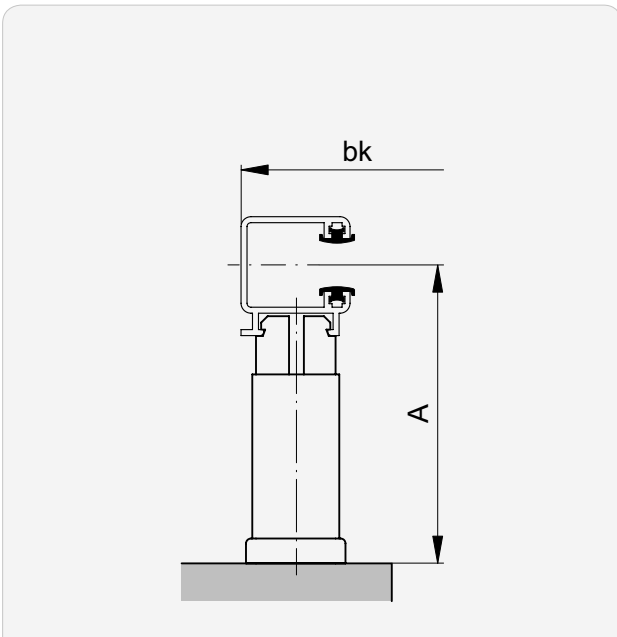

Only with guide type C | T | R

Console for type Kv

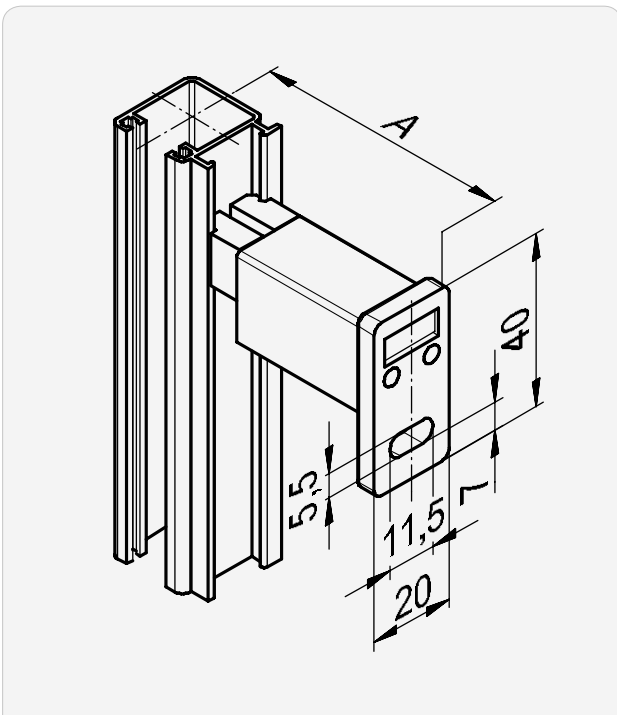

A	A
60... 75	121... 135
76... 90	136... 150
91... 105	151... 165
106... 120	166... 180
	181... 195

►► Guide rail fastenings (principle)

M Installation with centre bracket

i Only with guide type E
Length = Guide length

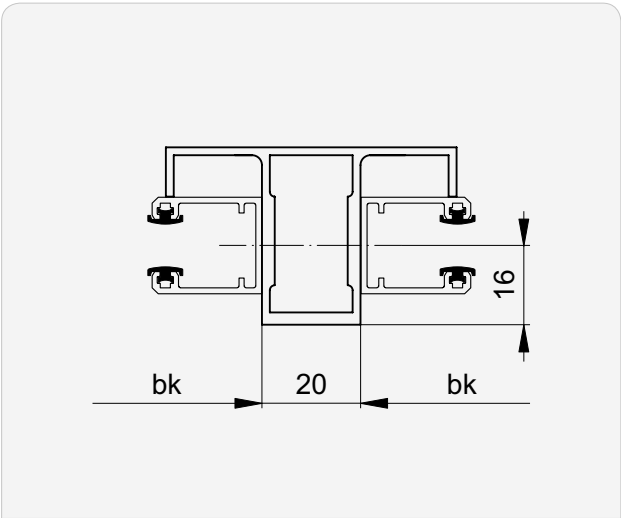

Principle

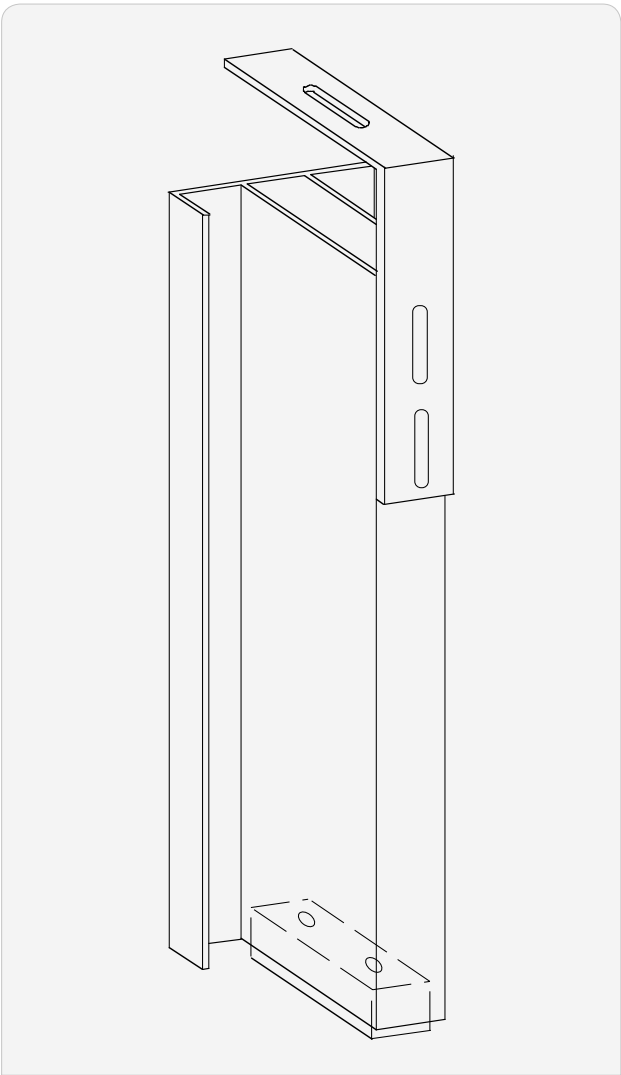

Fastening bracket above centre bracket

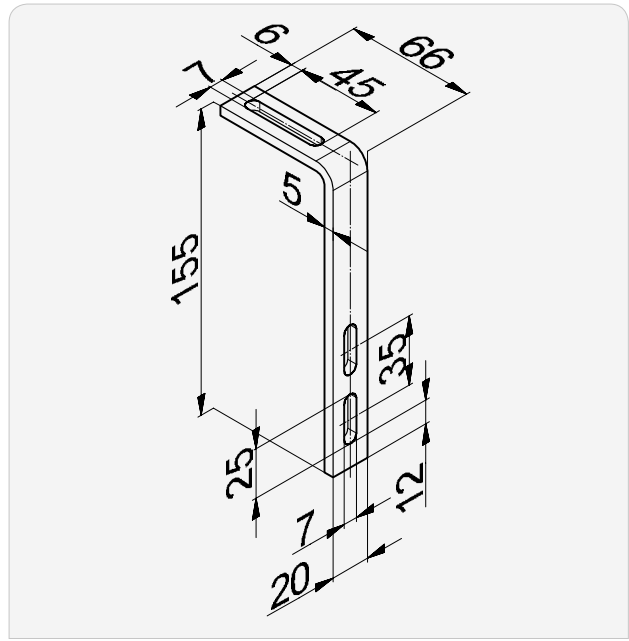

Fastening square below for centre bracket

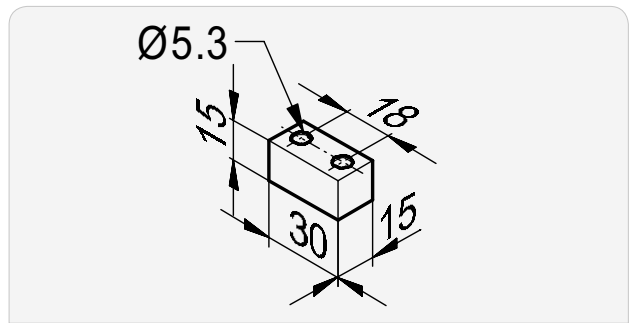

►► Guide rail fastenings (principle)

T Installation with T-bracket

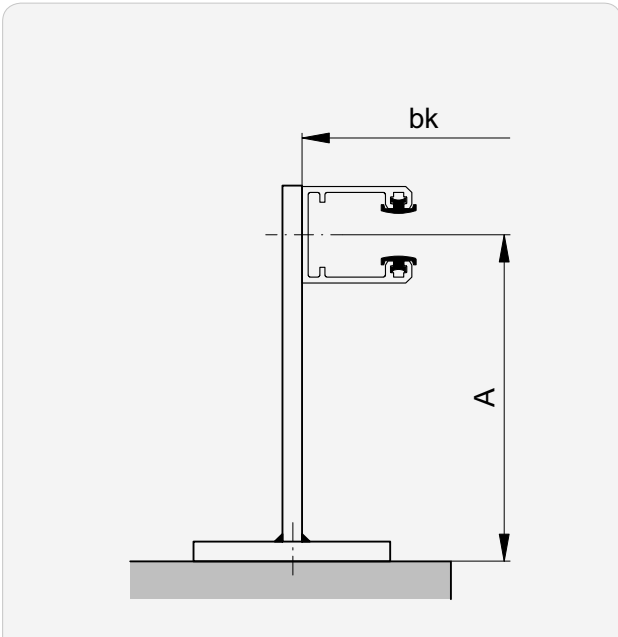

Tv Installation with adjustable T-bracket

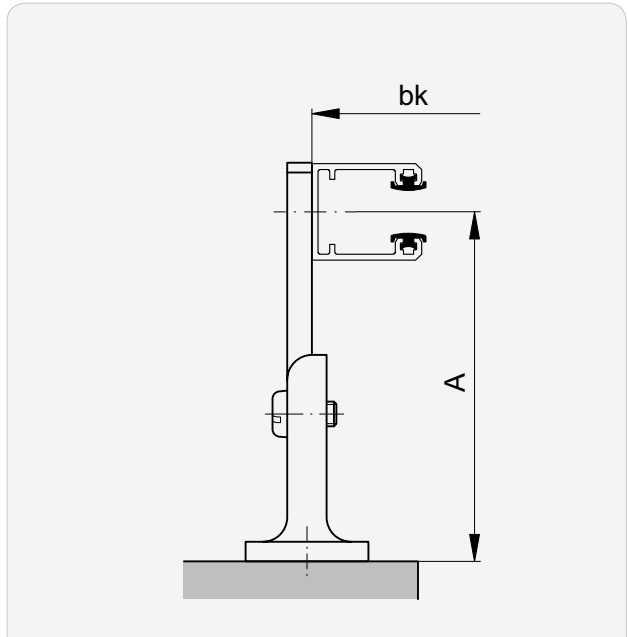

T-bracket for type T

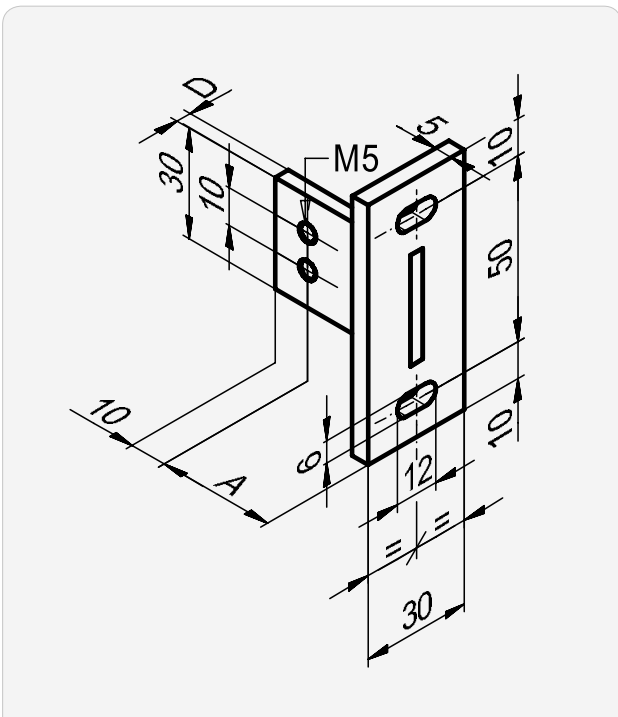

T-bracket adjustable for type Tv

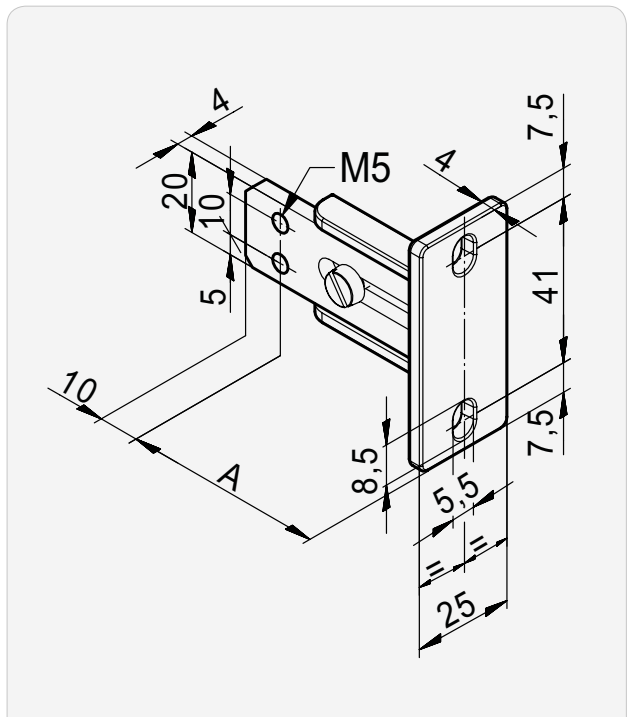

A*	D
20... 115	4
120... 215	5

A
50... 68
69... 87
88... 106
107... 115

* in 5 mm steps

►► Guide rail fastenings (principle)

V Installation with one bracket

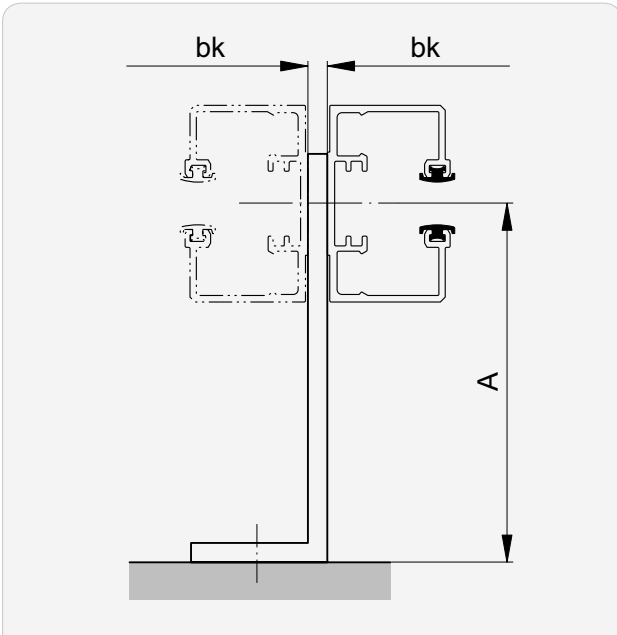

The blind on the right uses the fastening for the blind on the left.

Wv Installation with adjustable bracket

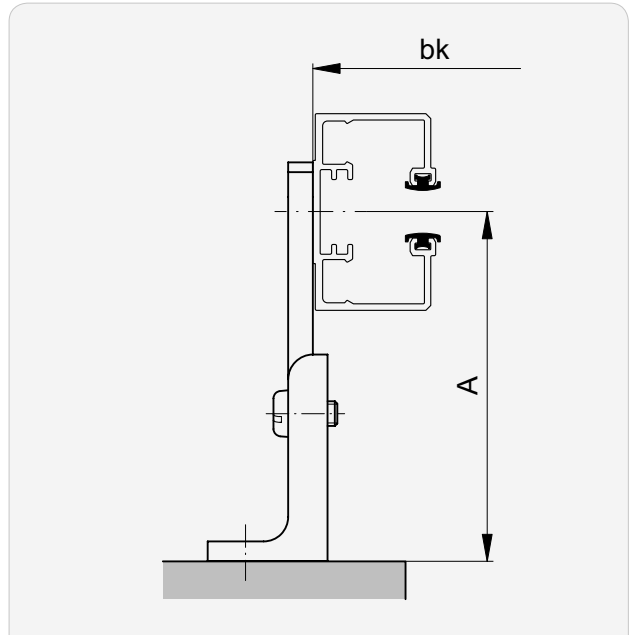

W-bracket adjustable for type Wv

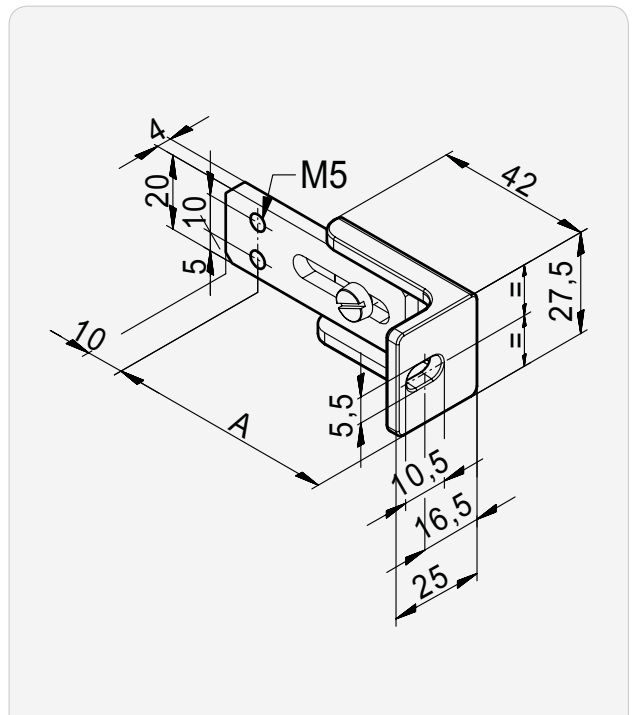

A
50...68
69...87
88...106
107...115

Guide extension and facet

Extension

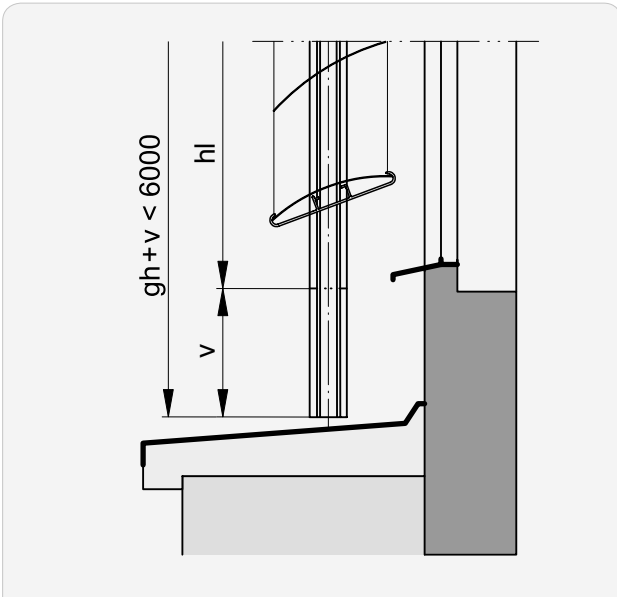

v
-20... 3000

Facet

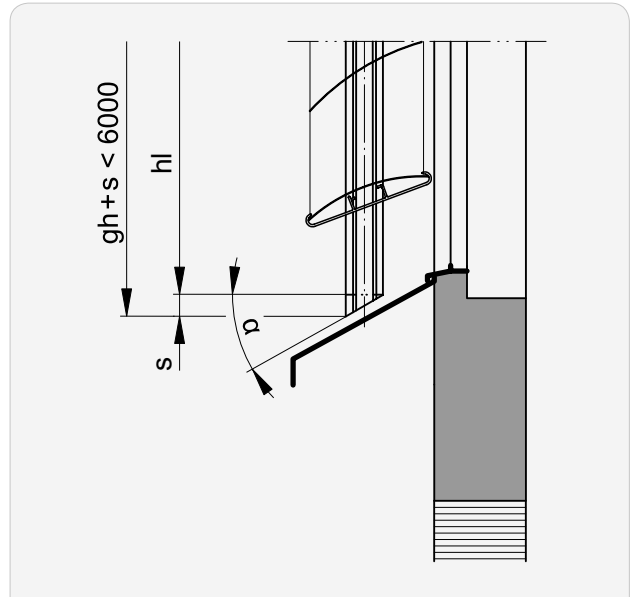

α
5... 50°

Extension and facet

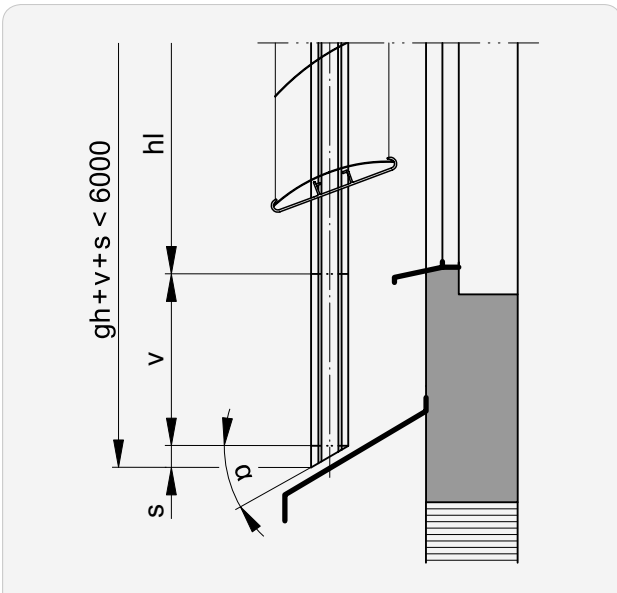

v
0... 3000

α
5... 50°

➔ Value for **s**..... 216

Angling at the guides

Type E | Single guide

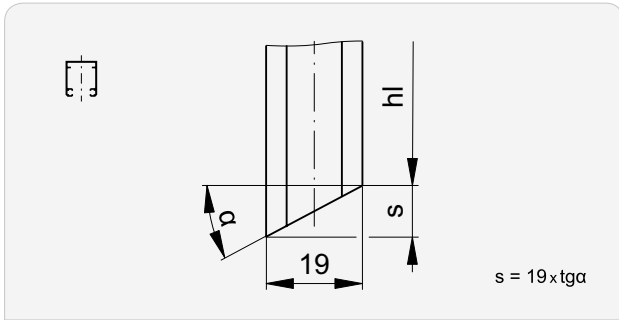

α	s	α	s	α	s	α	s	α	s
5	2	15	5	25	9	35	13	45	19
6	2	16	5	26	9	36	14	46	20
7	2	17	6	27	10	37	14	47	20
8	3	18	6	28	10	38	15	48	21
9	3	19	7	29	11	39	15	49	22
10	3	20	7	30	11	40	16	50	23
11	4	21	7	31	11	41	17		
12	4	22	8	32	12	42	17		
13	4	23	8	33	12	43	18		
14	5	24	8	34	13	44	18		

Type C | Single guide

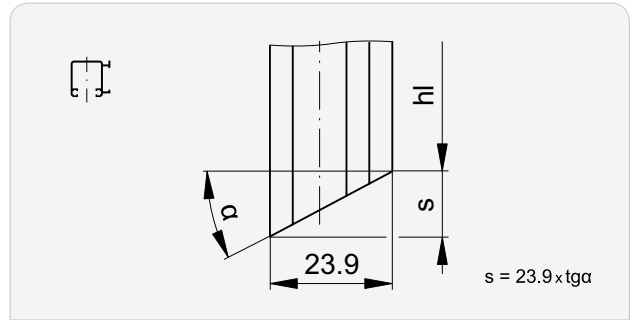

α	s	α	s	α	s	α	s	α	s
5	2	15	6	25	11	35	17	45	24
6	3	16	7	26	12	36	17	46	25
7	3	17	7	27	12	37	18	47	26
8	3	18	8	28	13	38	19	48	27
9	4	19	8	29	13	39	19	49	27
10	4	20	9	30	14	40	20	50	28
11	5	21	9	31	14	41	21		
12	5	22	10	32	15	42	22		
13	6	23	10	33	16	43	22		
14	6	24	11	34	16	44	23		

Type L | Fix guide

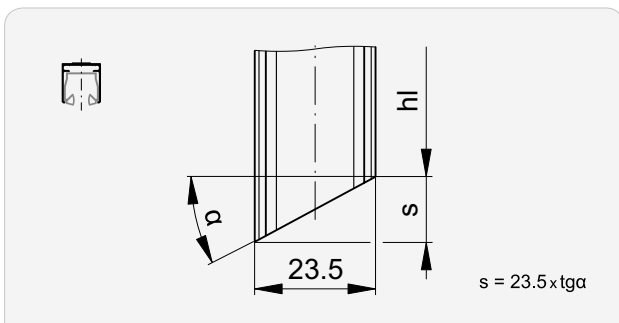

α	s	α	s	α	s	α	s	α	s
5	2	15	6	25	11	35	16	45	24
6	2	16	7	26	11	36	17	46	24
7	3	17	7	27	12	37	18	47	25
8	3	18	8	28	12	38	18	48	26
9	4	19	8	29	13	39	19	49	27
10	4	20	9	30	14	40	20	50	28
11	5	21	9	31	14	41	20		
12	5	22	9	32	15	42	21		
13	5	23	10	33	15	43	22		
14	6	24	10	34	16	44	23		

Type F | Fix guide

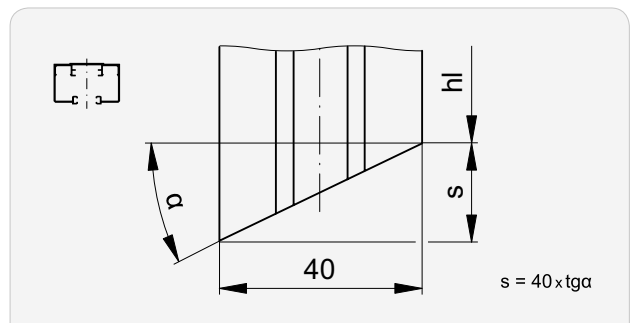

α	s	α	s	α	s	α	s	α	s
5	3	15	11	25	19	35	28	45	40
6	4	16	11	26	20	36	29	46	41
7	5	17	12	27	20	37	30	47	43
8	6	18	13	28	21	38	31	48	44
9	6	19	14	29	22	39	32	49	46
10	7	20	15	30	23	40	34	50	48
11	8	21	15	31	24	41	35		
12	9	22	16	32	25	42	36		
13	9	23	17	33	26	43	37		
14	10	24	18	34	27	44	39		

►► Angling at the guides

Type T | Double guide

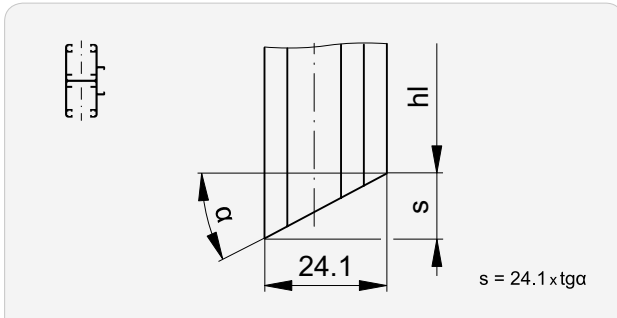

α	s	α	s	α	s	α	s	α	s
5	2	15	6	25	11	35	17	45	24
6	3	16	7	26	12	36	18	46	25
7	3	17	7	27	12	37	18	47	26
8	3	18	8	28	13	38	19	48	27
9	4	19	8	29	13	39	20	49	28
10	4	20	9	30	14	40	20	50	29
11	5	21	9	31	14	41	21		
12	5	22	10	32	15	42	22		
13	6	23	10	33	16	43	22		
14	6	24	11	34	16	44	23		

Type D | Double guide

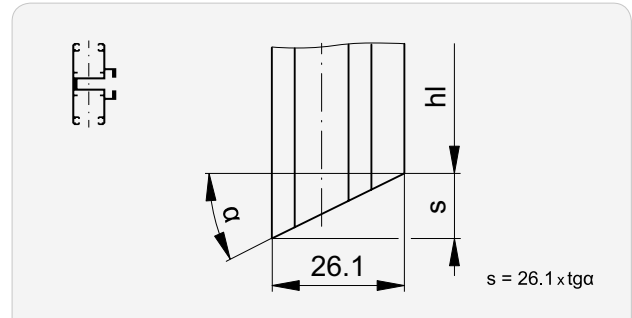

α	s	α	s	α	s	α	s	α	s
5	2	15	7	25	12	35	18	45	26
6	3	16	7	26	13	36	19	46	27
7	3	17	8	27	13	37	20	47	28
8	4	18	8	28	14	38	20	48	29
9	4	19	9	29	14	39	21	49	30
10	5	20	9	30	15	40	22	50	31
11	5	21	10	31	16	41	23		
12	6	22	11	32	16	42	24		
13	6	23	11	33	17	43	24		
14	7	24	12	34	18	44	25		

Type R | Curved double guide

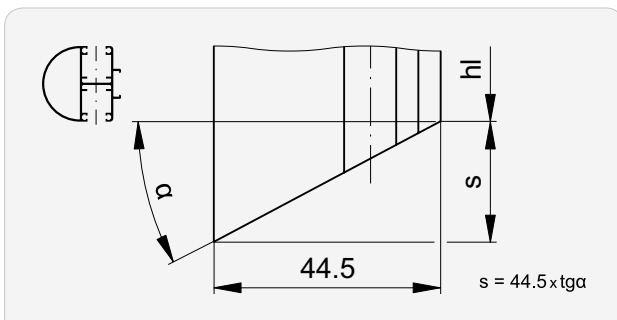

α	s	α	s	α	s	α	s	α	s
5	4	15	12	25	21	35	31	45	45
6	5	16	13	26	22	36	32	46	46
7	5	17	14	27	23	37	34	47	48
8	6	18	14	28	24	38	35	48	50
9	7	19	15	29	25	39	36	49	51
10	8	20	16	30	26	40	37	50	53
11	9	21	17	31	27	41	39		
12	9	22	18	32	28	42	40		
13	10	23	19	33	29	43	42		
14	11	24	20	34	30	44	43		

Guide rail cut-outs in windowsill area

Guide type						
C	D	E	F	L	R	T
-	-	●	●	●	-	-

Rear cut-out | with extension

Extension | $v \geq A$

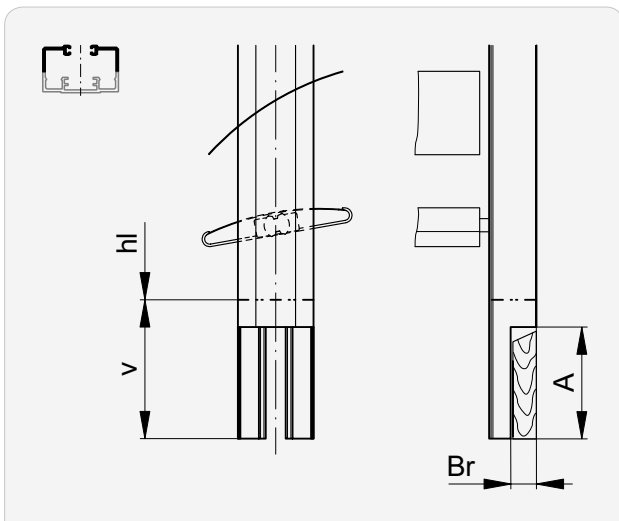

A ($\leq v$)	Guide type	Br		
		E	F	L*
0...25		2...3	2...4	2...4
		5...12	9...12	6

* FL \geq 630

Inner cut-out | without/with extension

Extension | $v \geq A$

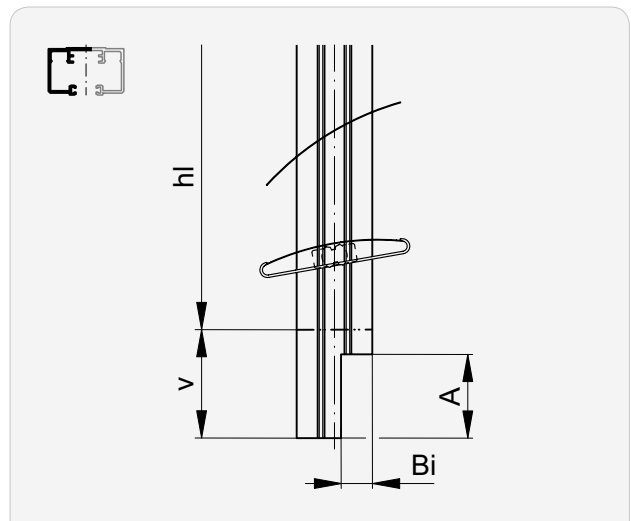

A ($\leq v$)	Guide type	Bi		
		E	F	L*
0...25		6...12	3...10	8...12

* FL \geq 630

v Guide rail extension: 0...3000

Guide rail end for suspended guide rails

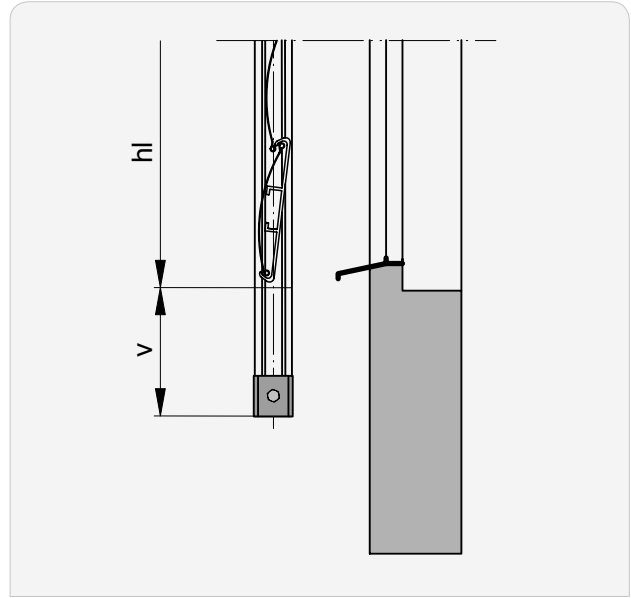
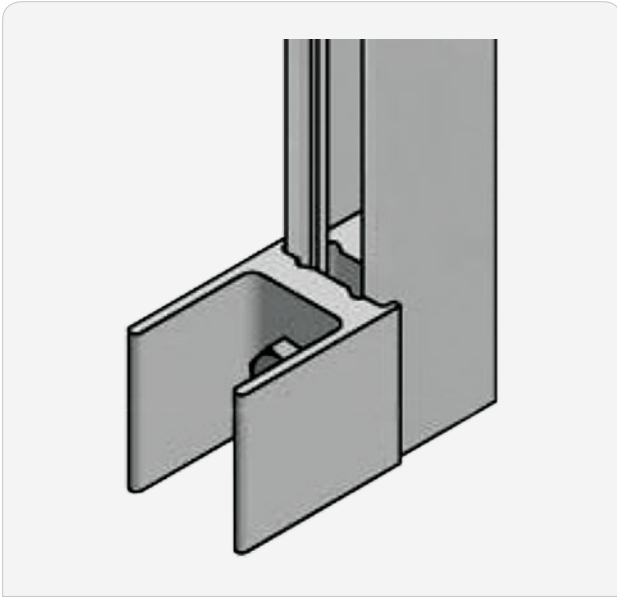

Guide type						
C	D	E	F	L	R	T
●	●	●	●	●	●	●

L*	v
70	≥30

* Guide fastening with local brackets.

Guide extension for window sill installation

i For additional intermediate cables with “tensioning bracket down”, **the guide rails must be extended 60 mm for window ledge mounting.**

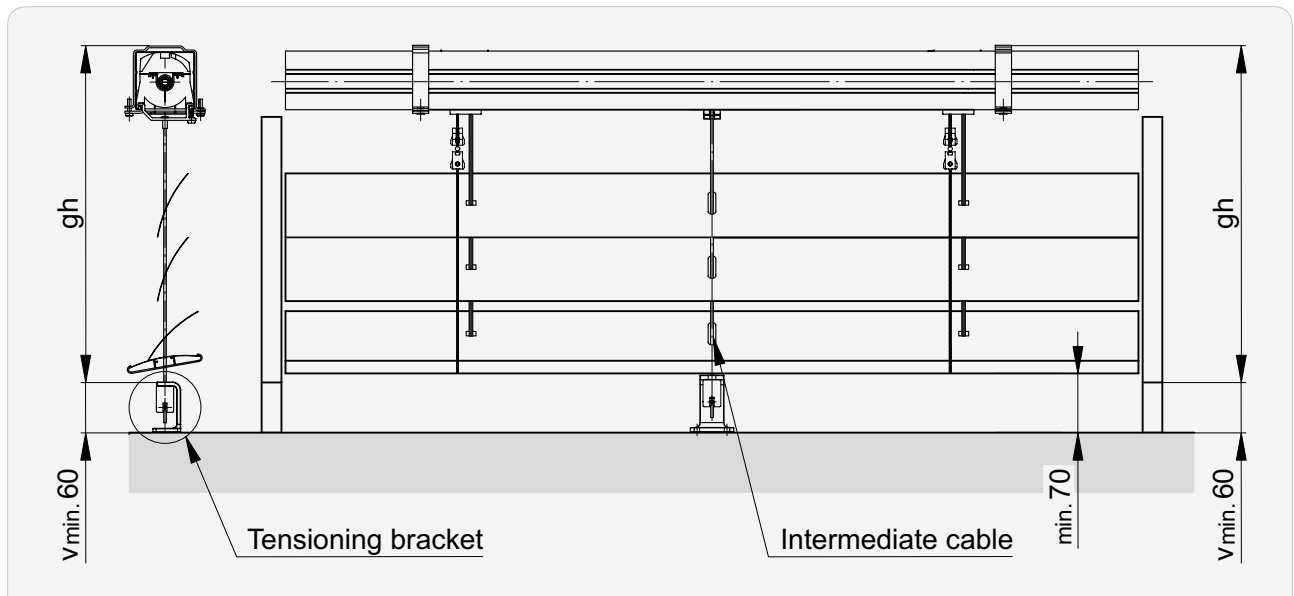

Installation window

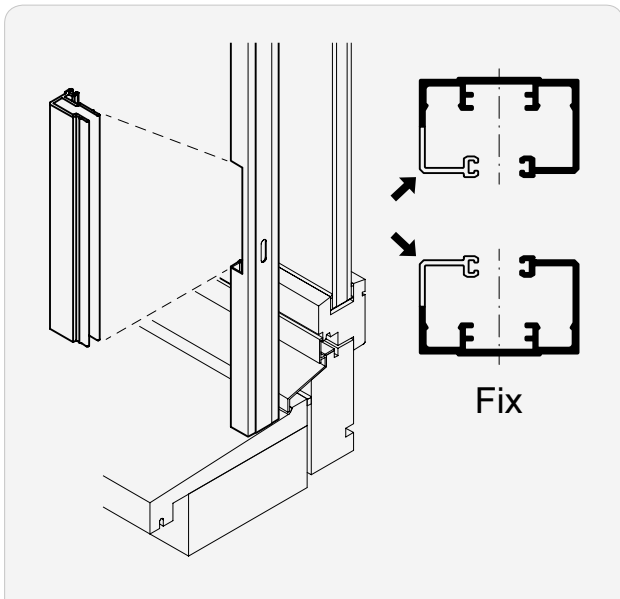

Without extension

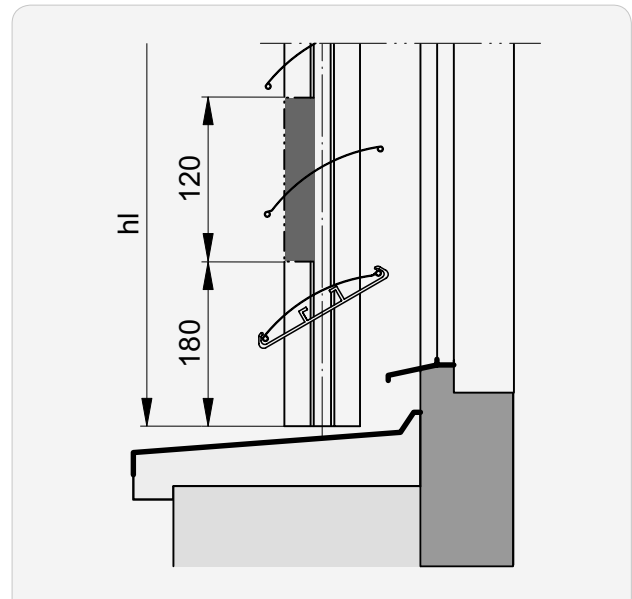

With extension

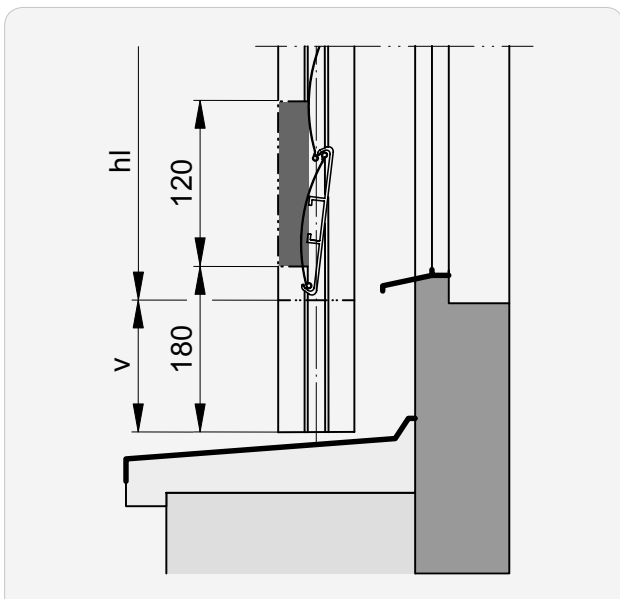

With extension and facet

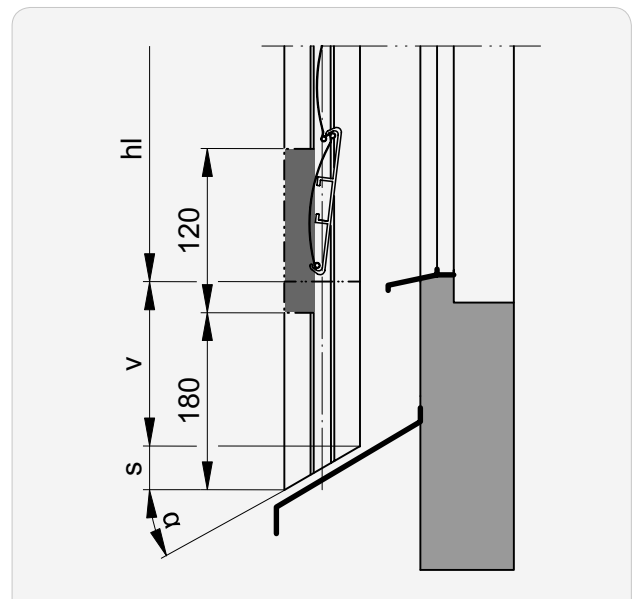

- s** Faceting (guide rail width x $\tan\alpha$)
- v** Guide rail extension: max. 3000

Fastening points



Without extension

Z	AS
≤ 1500	2
1501 ... 2700	3
2701 ... 3900	4
3901 ... 5100	5
> 5100	6

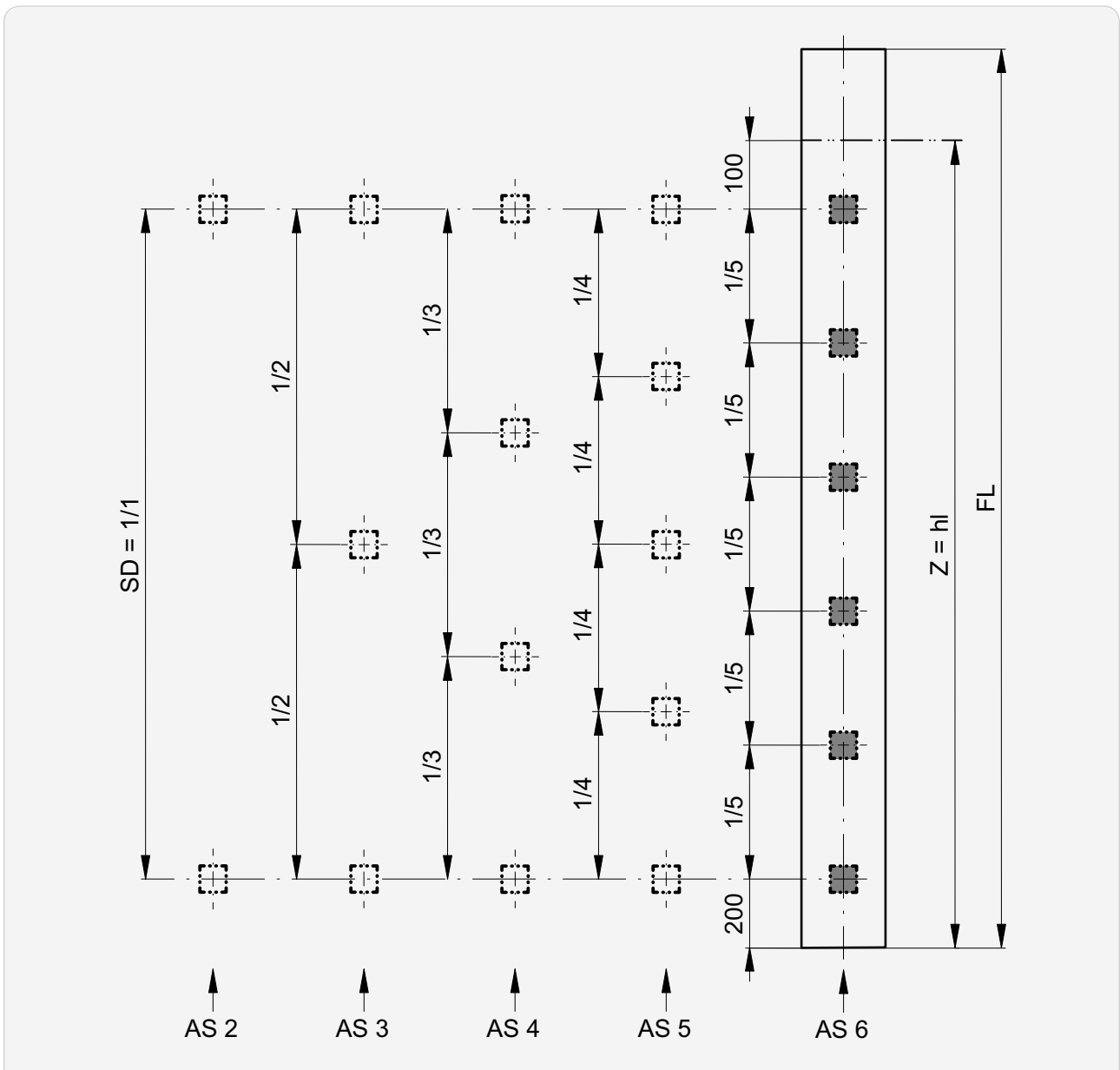

AS Number of slits

SD Slot spacing: max. 1200

►► Fastening points

With guide rail extension

Z	AS
≤ 1500	2
1501 ... 2700	3
2701 ... 3900	4
3901 ... 5100	5
> 5100	6

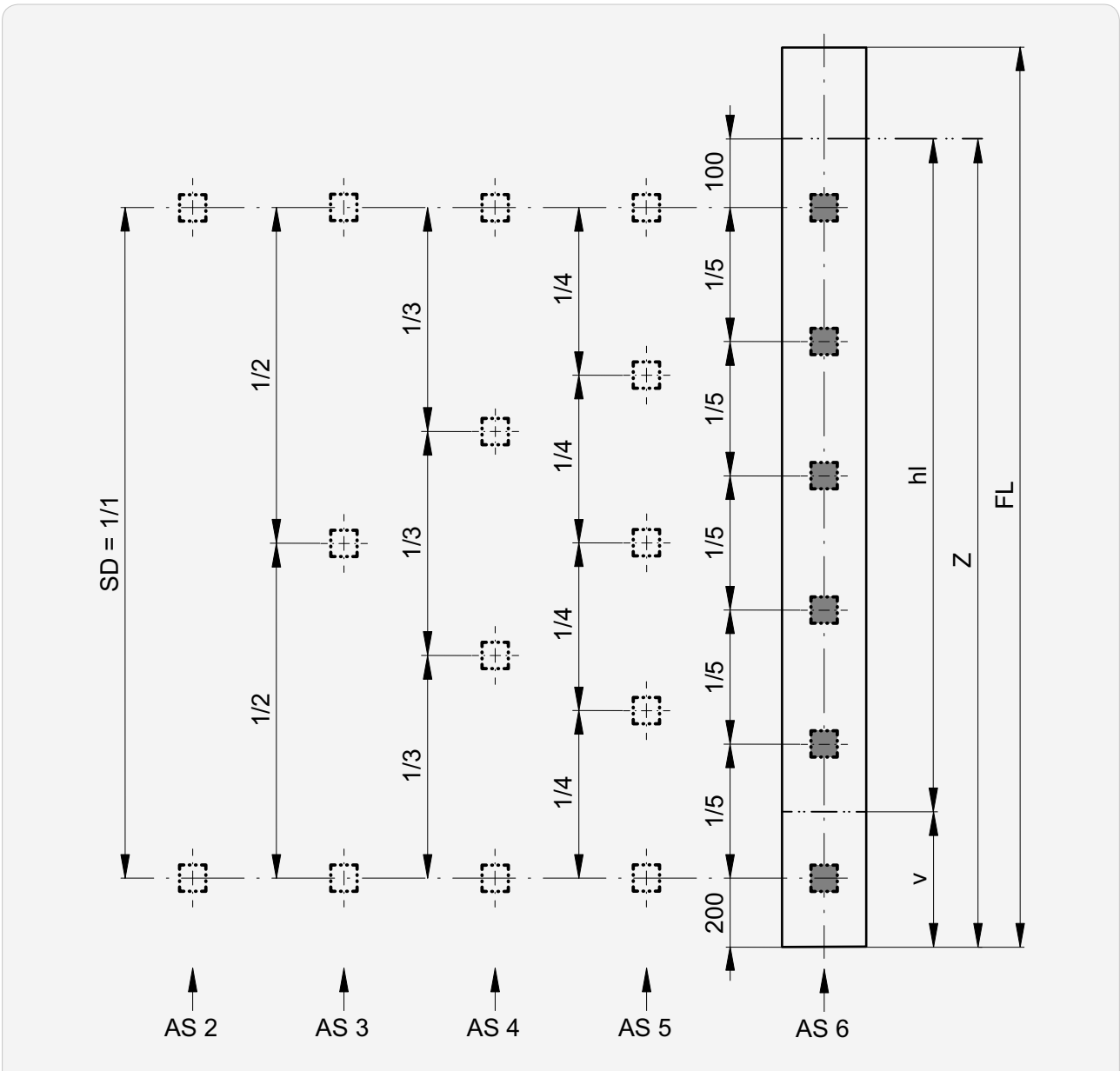

AS Number of slits
SD Slot spacing: max. 1200

v Guide rail extension: max. 3000

► Guide extension and facet.....	215	► Installation window.....	220
► Guide rail fastenings	207		

►► Fastening points

With facet

Z	AS
≤ 1500	2
1501 ... 2700	3
2701 ... 3900	4
3901 ... 5100	5
> 5100	6

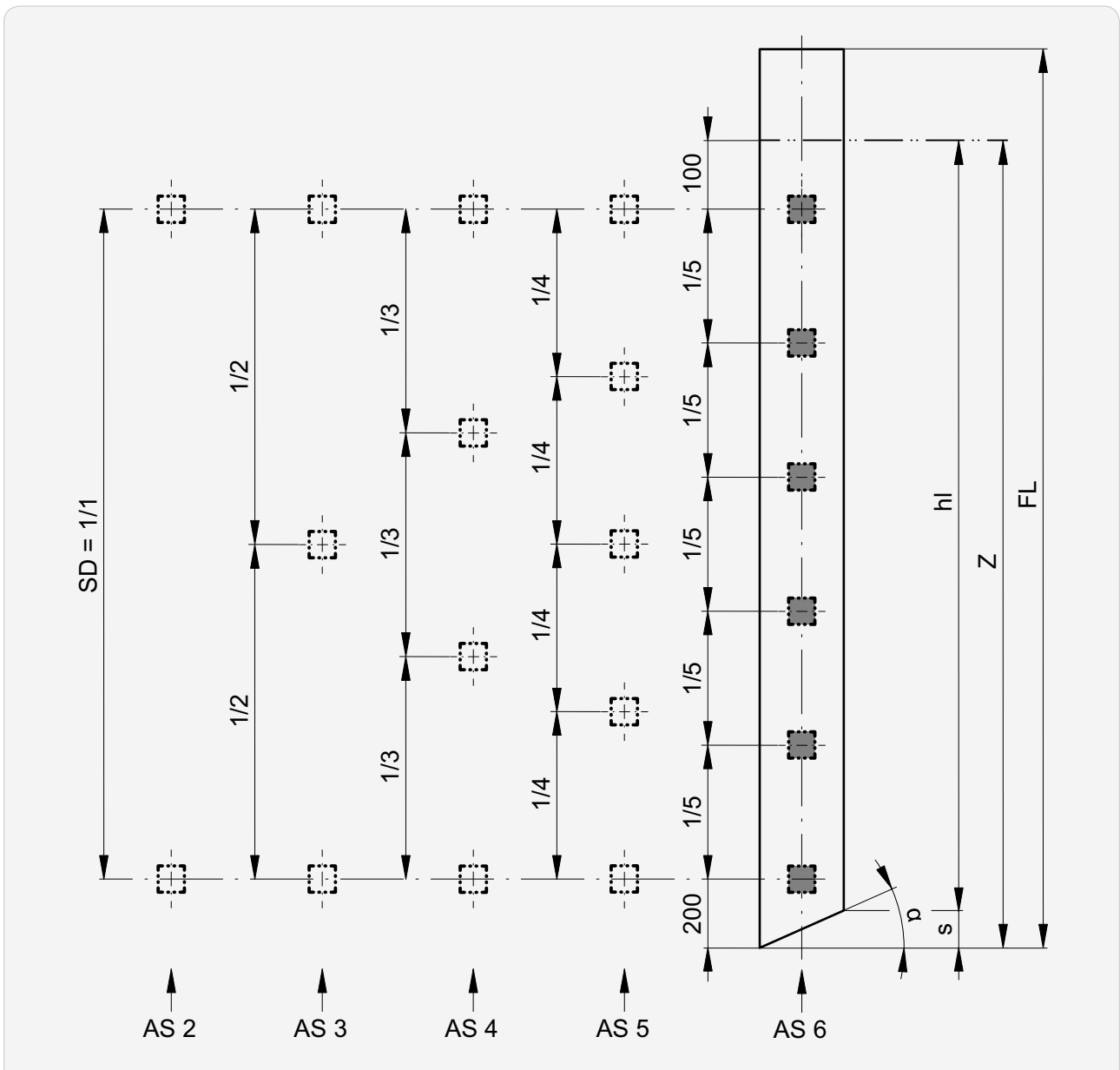

AS Number of slits

SD Slot spacing: max. 1200

s Faceting (guide rail width x tgα)

► Guide extension and facet 215
 ► Guide rail fastenings 207

► Installation window 220

►► Fastening points

With guide rail extension and facet

Z	AS
≤ 1500	2
1501 ... 2700	3
2701 ... 3900	4
3901 ... 5100	5
> 5100	6

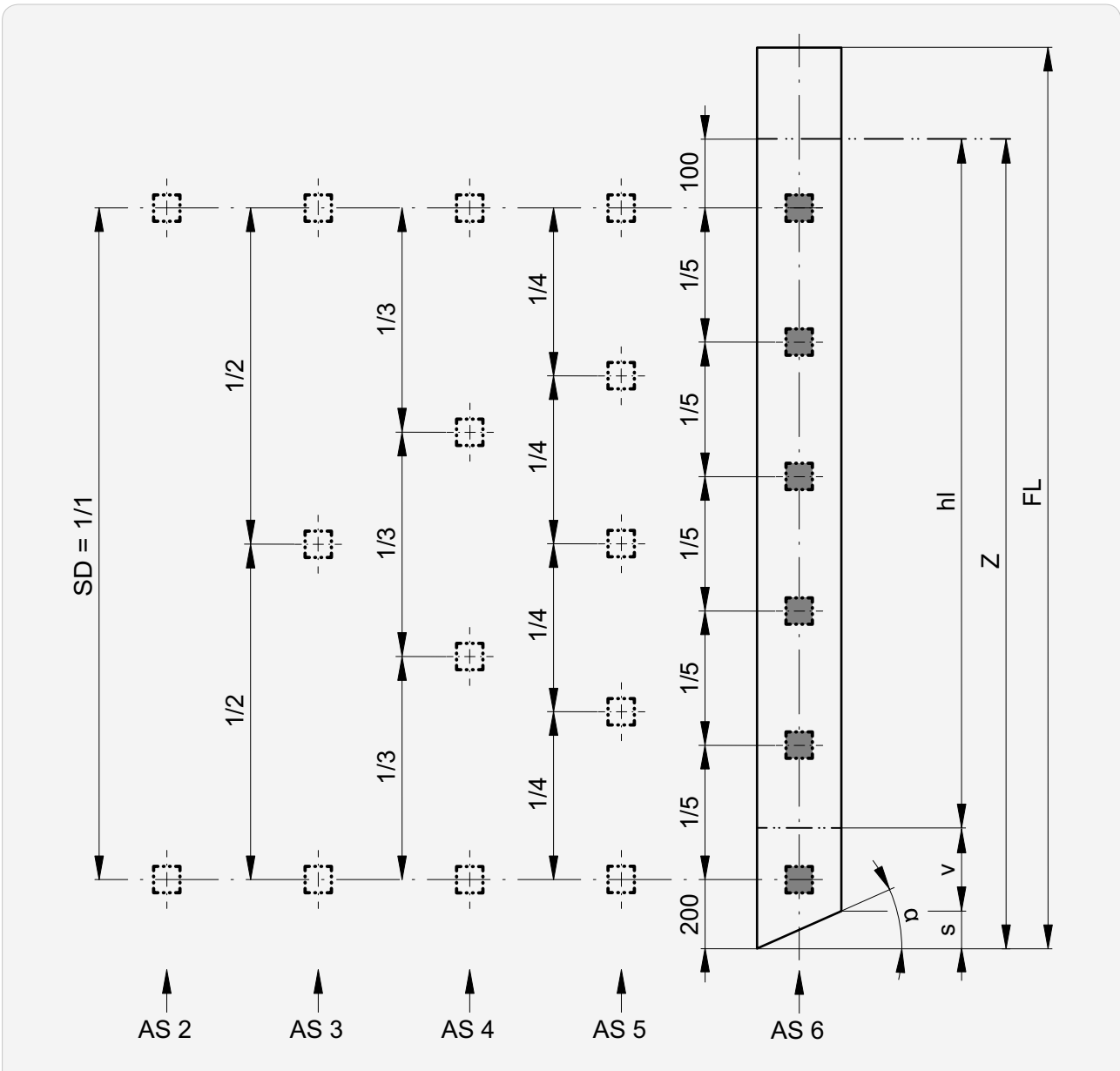

AS Number of slits

s Faceting (guide rail width \times $\tan \alpha$)

SD Slot spacing: max. 1200

v Guide rail extension: max. 3000

► Guide extension and facet 215
 ► Guide rail fastenings 207

► Installation window 220

Connected systems

System width

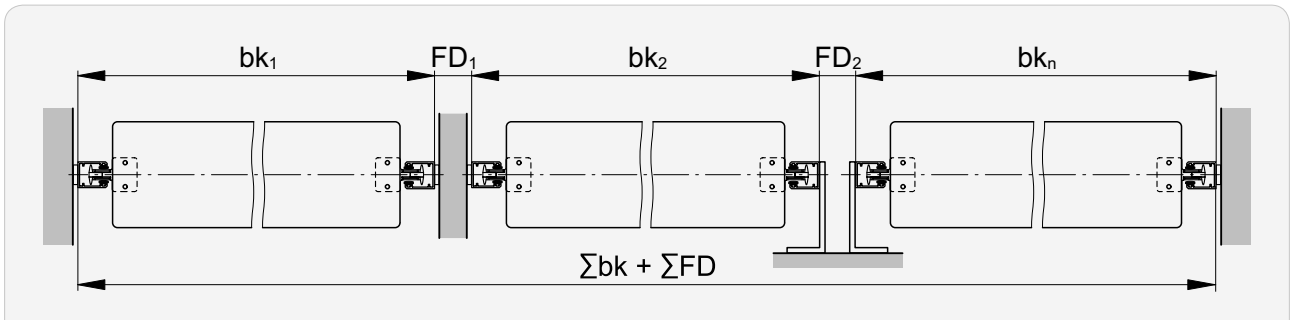

Distance between guides FD

Single guide | Fix guide

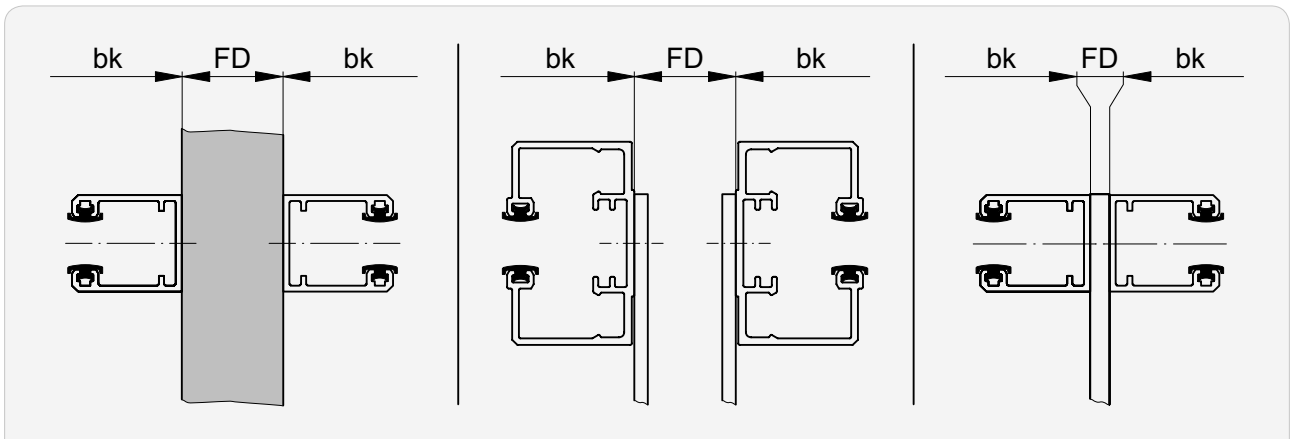

FD min.	FD max.
5	1000

Double guide

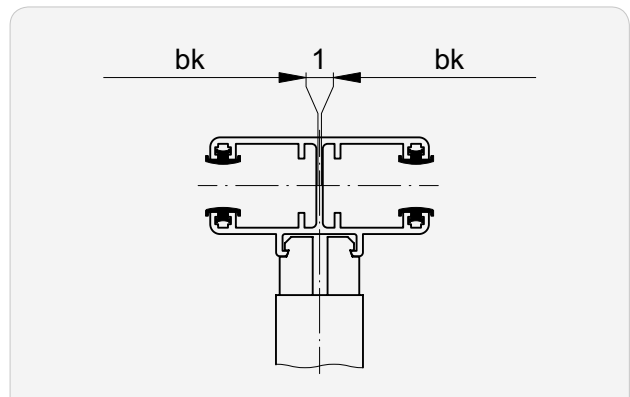
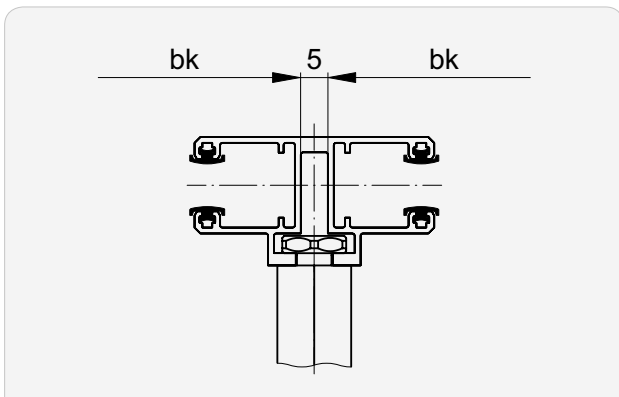

➔ Opening for connected blinds 226

►► Connected systems

Drive position

Gearbox

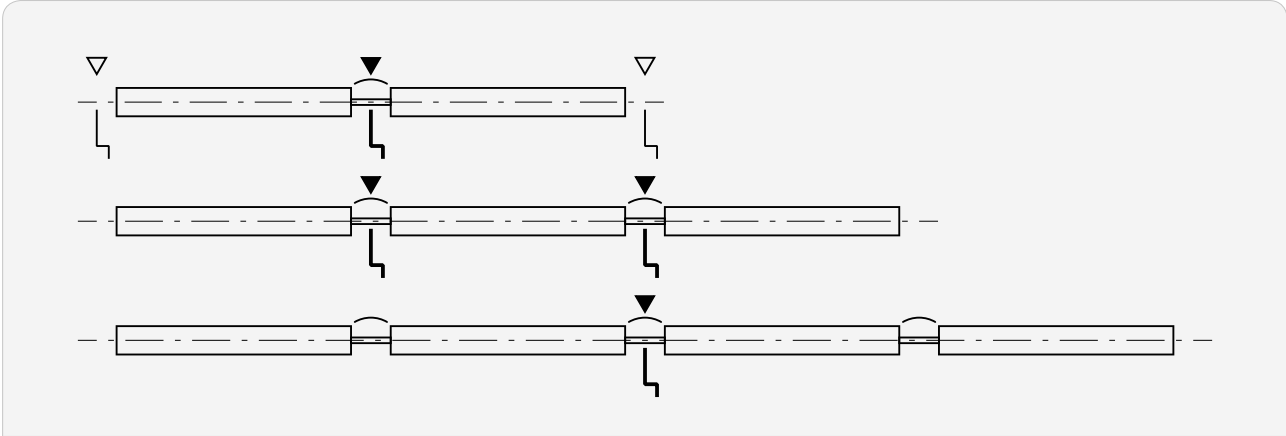

Motor

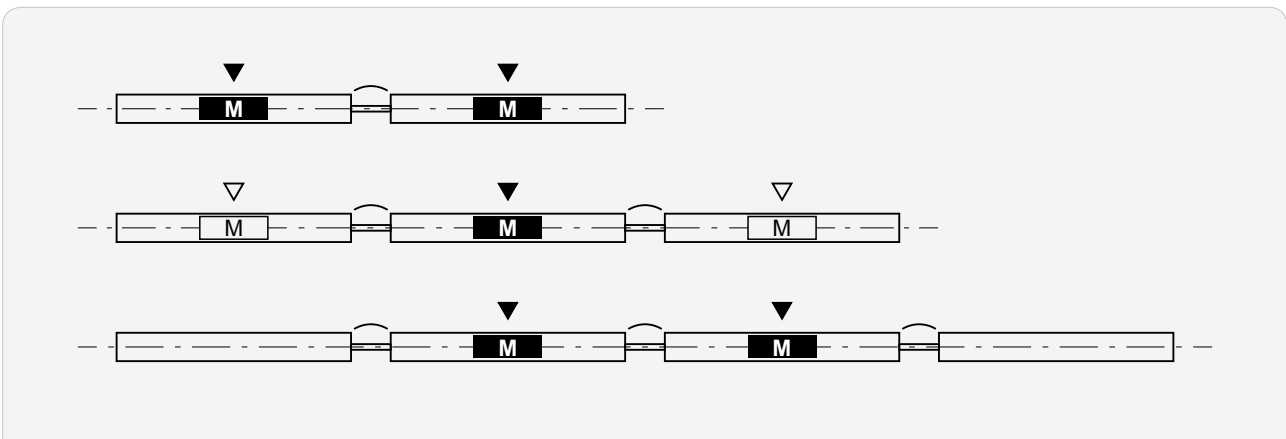

▼ Standard drive position

▽ Possible drive position

Opening for connected blinds

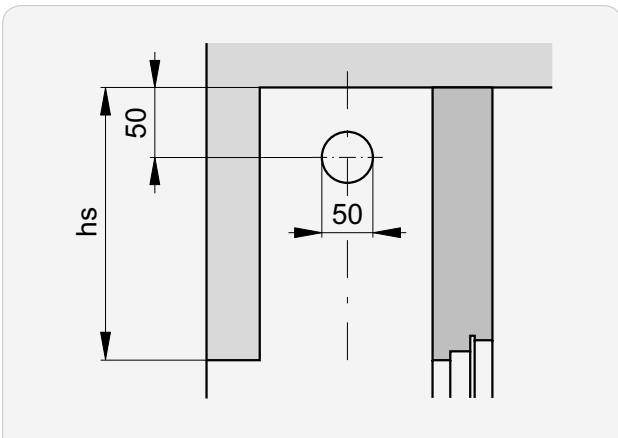

Cable guide Details

Soffit/facade mounting

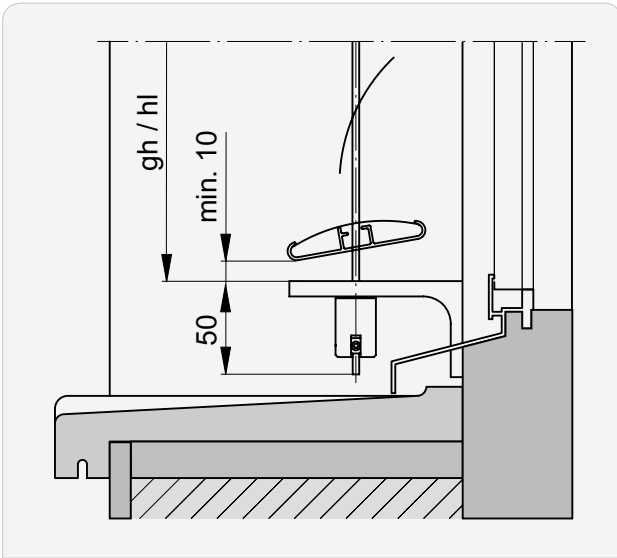

Window ledge mounting

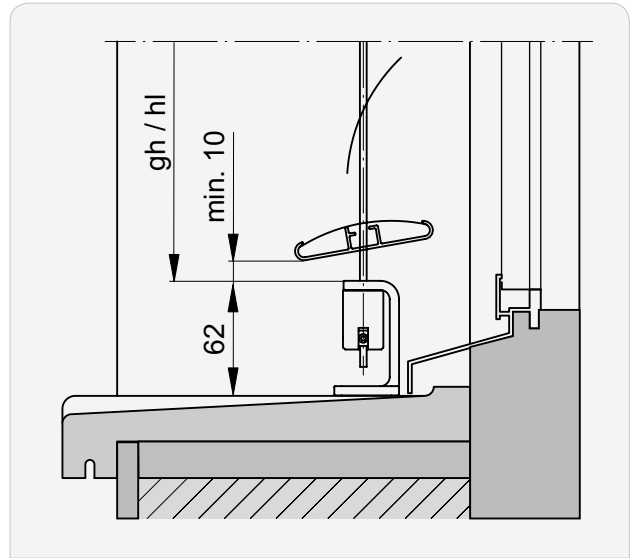

➔ Cable fastenings..... 234

➔ Distance between guides **FD**..... 236

Horizontal section

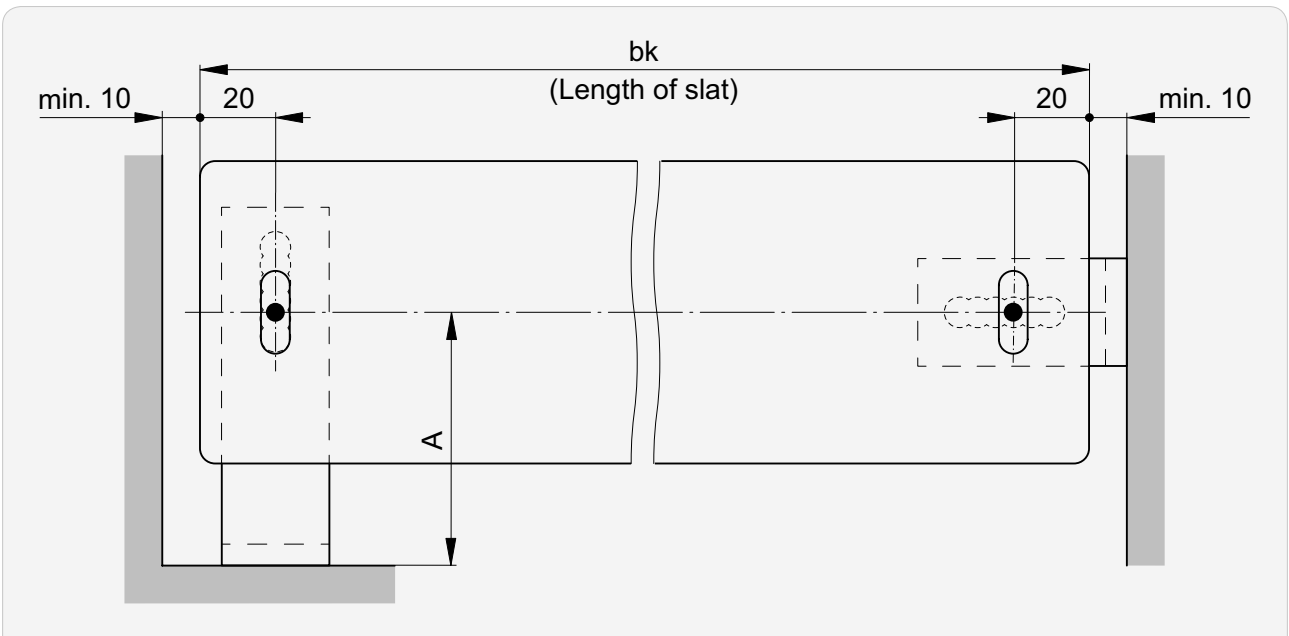

➔ Value for **A**..... 187

►► Sections | Details

Horizontal section: Box

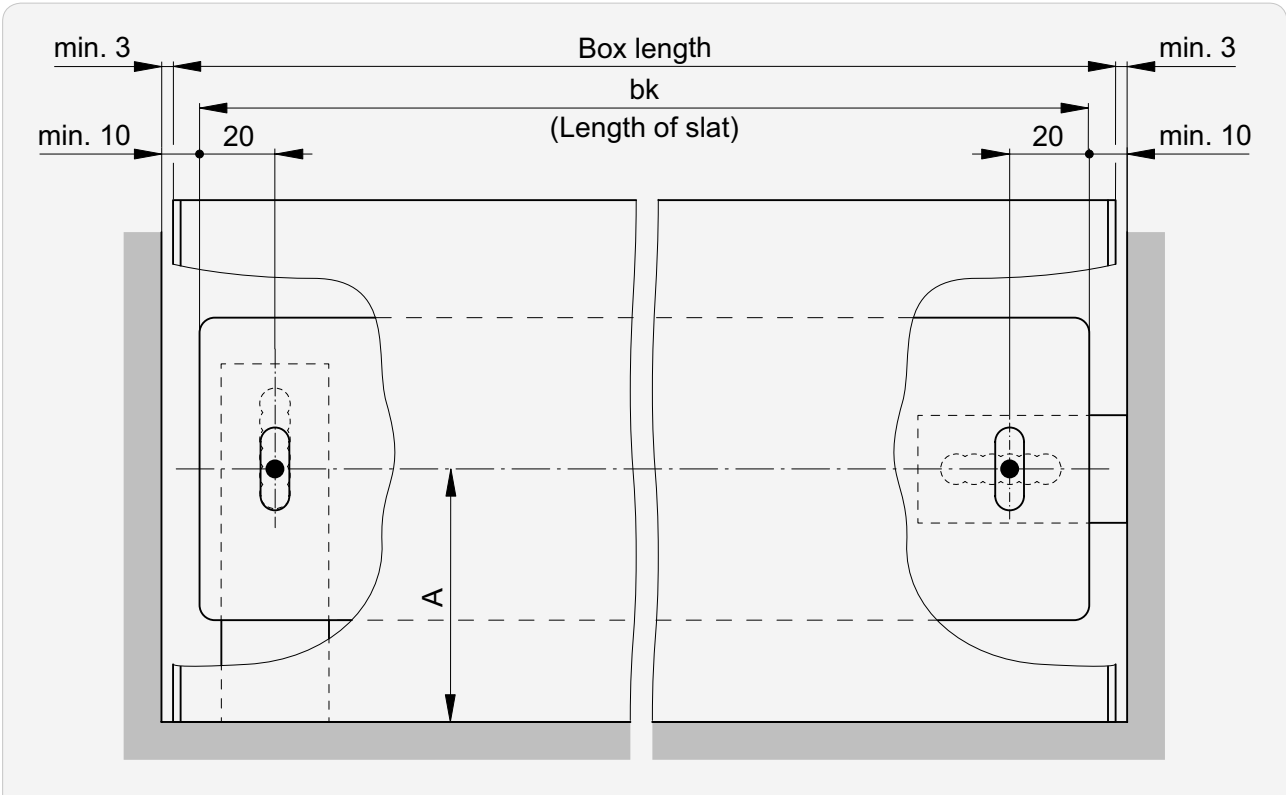

➡ Value for **A** 187

Horizontal section: Box extension

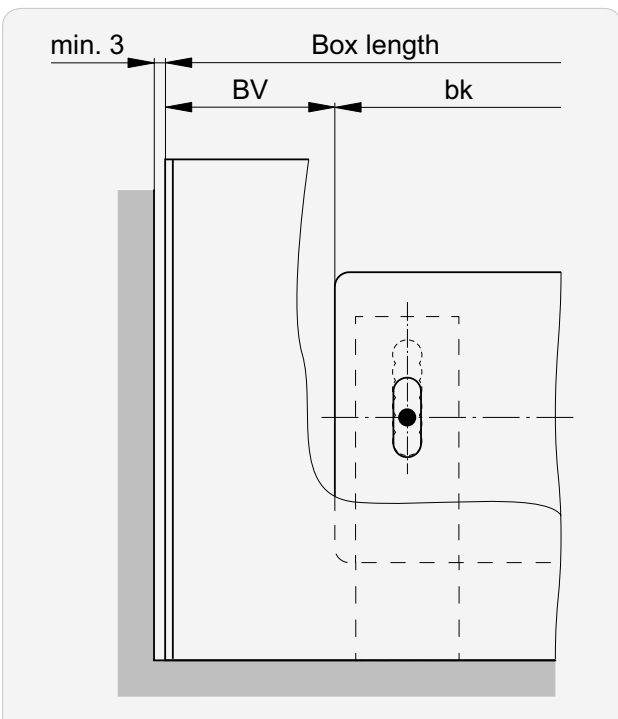

Sections for crank drive (MBMA)

outside bk

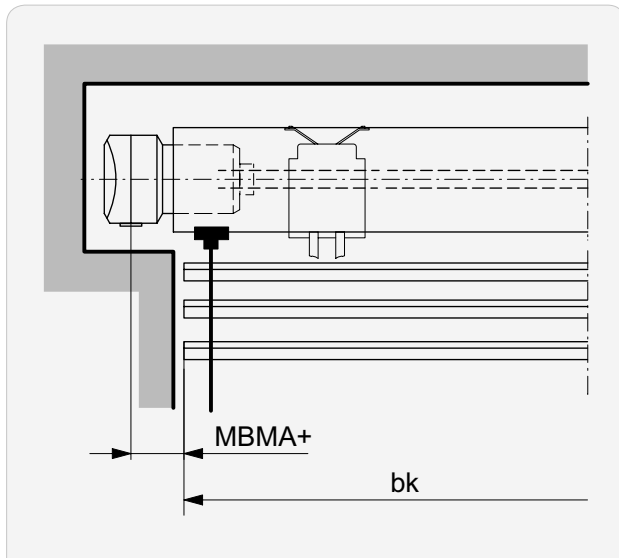

MBMA+¹

20 ... 999

within bk

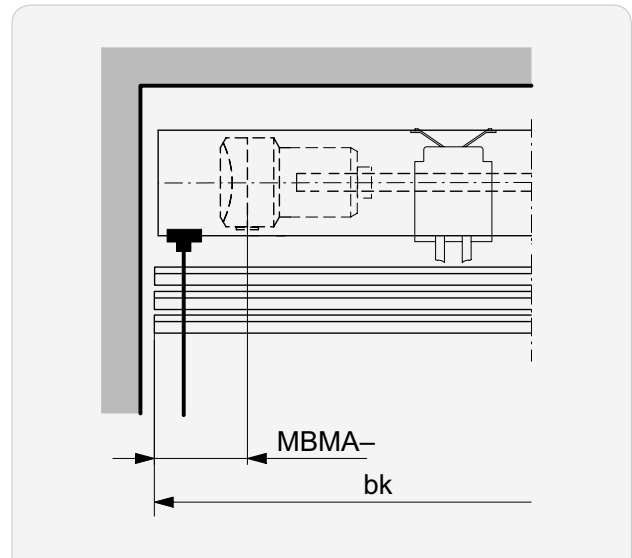

MBMA-

80 ... (bk/2)

¹ For 20 ... 44, provide enough niche depth for the housing extension.

Additional cables

i **Additional cables must be fitted for a $bk > 3000$ and in locations which are exposed to high wind.**
 The dimensions **P1** and **P2** are **measured from the left from bk and must be noted on the dimensions sheet.**
 P2 does not apply for the first additional cable.

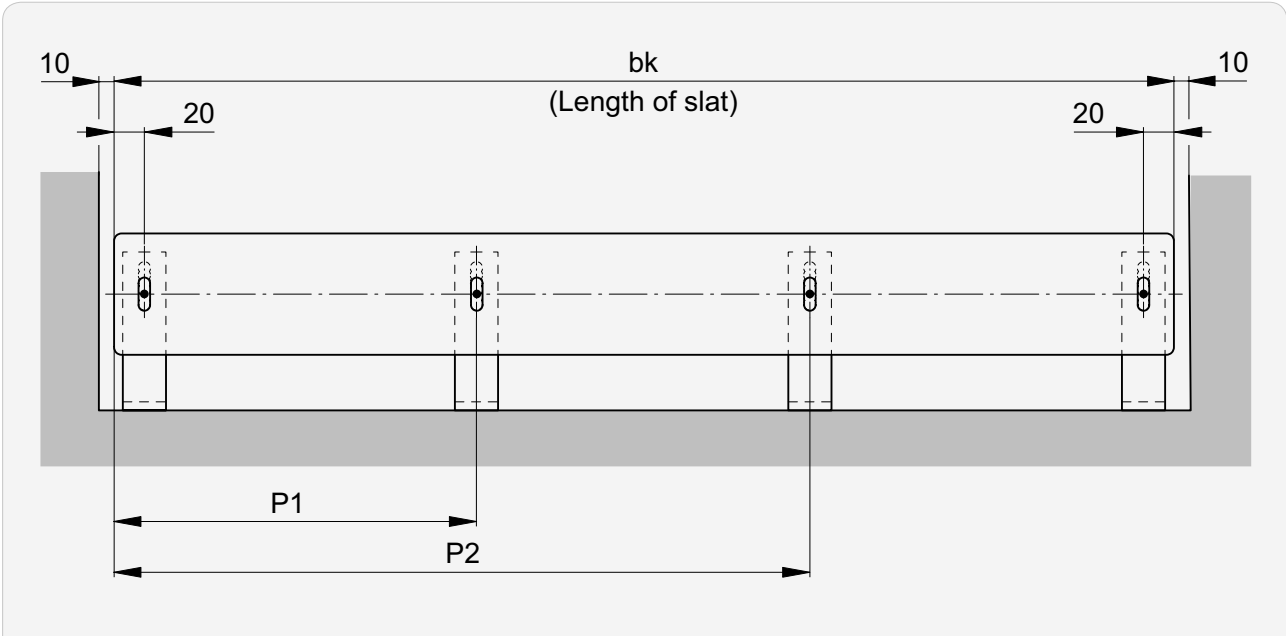

- P1** Position of first cable or cable on the left
- P2** Position of cable on the right

Number of additional cables

i **If no information is provided for $P1$ or $P2$, they are positioned according to the following table.**

Width max. (bk)	Number of additional cables	P1	P2
≤ 3000	0	–	–
3001 ... 4400	1	$(bk/2)$	–
> 4400	2	$(bk/3)$	$2 (bk/3)$

Vertical connections | Standard motor position

Number of bearings

Aluflex® 60

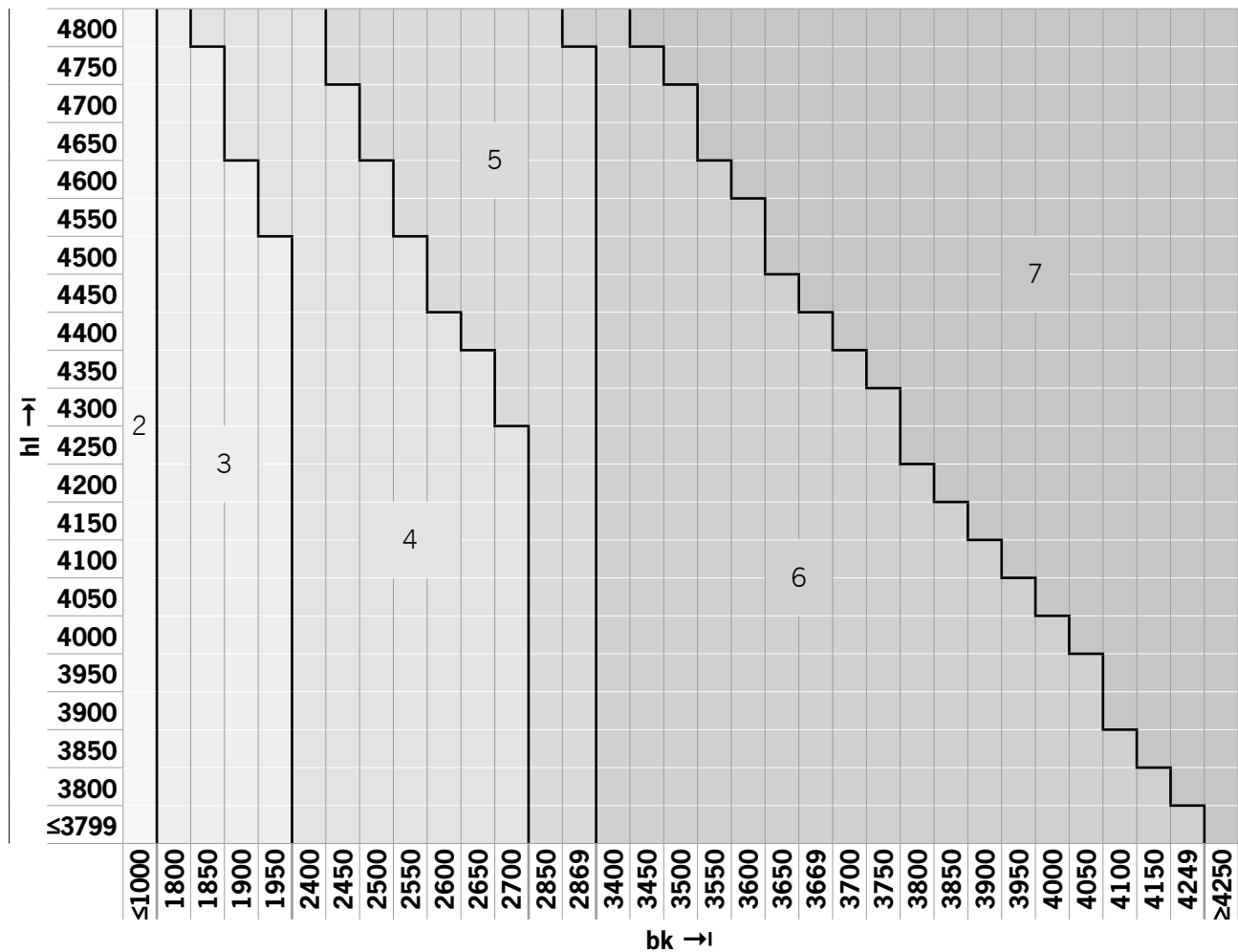

►► Vertical connections | Standard motor position





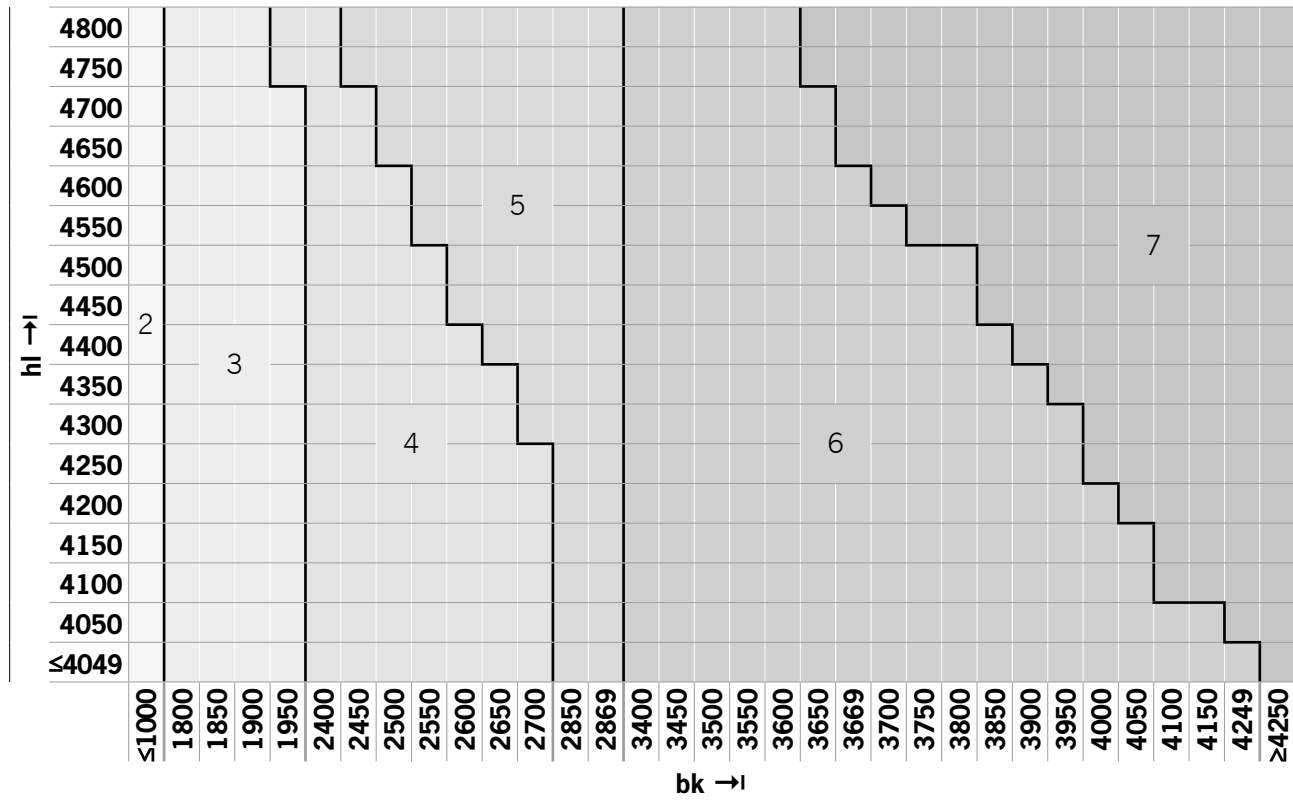

Number of bearings



Aluflex® 80

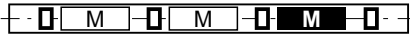

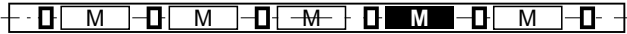
►► Vertical connections | Standard motor position

Standard motor position

Number of bearings	Standard motor position
2	
3	
4	
5	
6	
7	

-  Bearing
-  Standard motor position
-  Possible motor position (on request)

Cable fastenings

S Soffit or facade installation

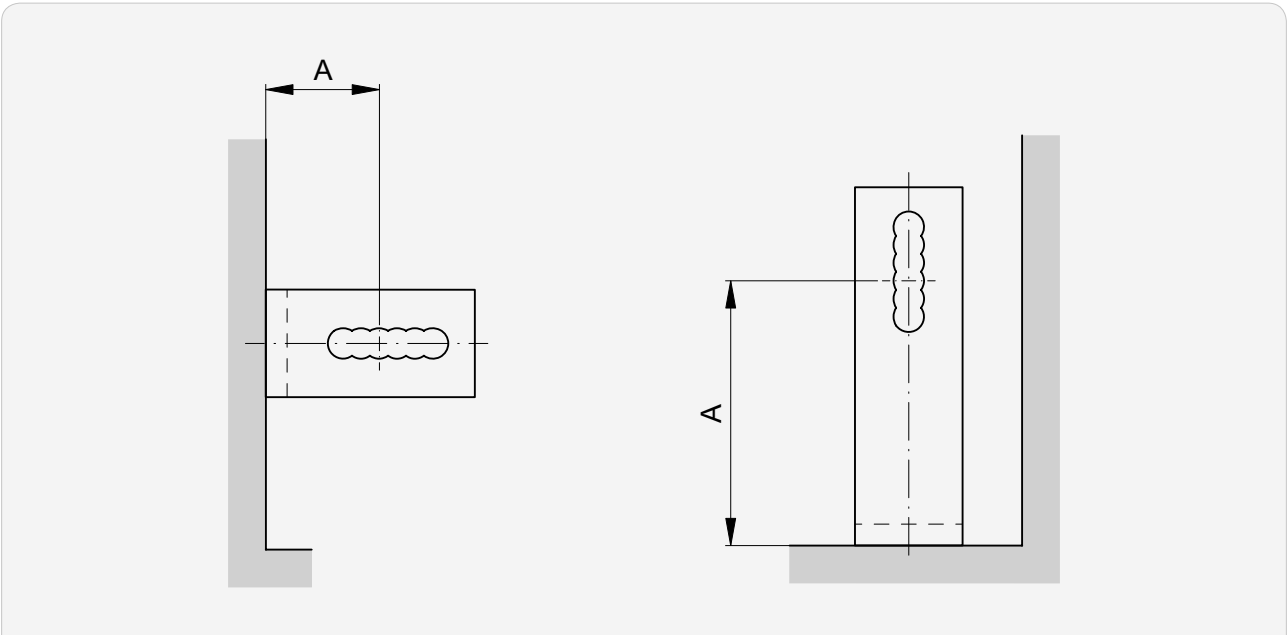

Tensioning bracket 20–40 for type S

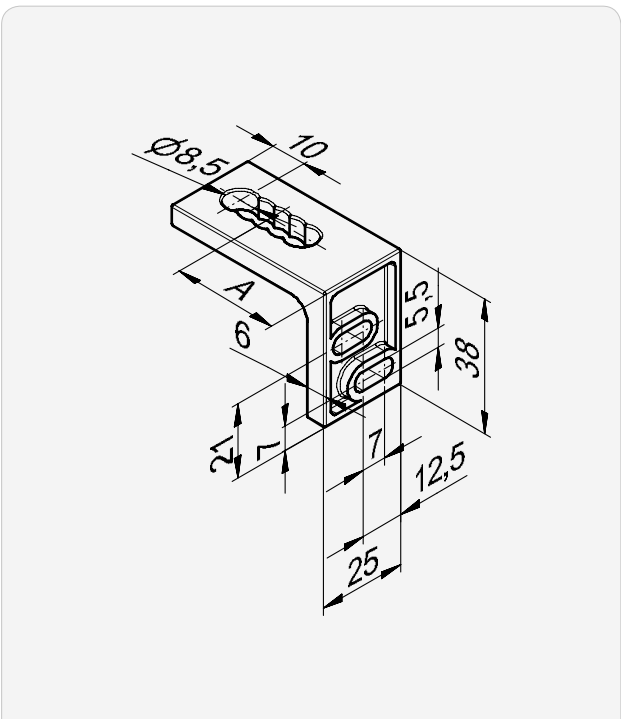

A
20...40*

Tensioning bracket 45–70 for type S

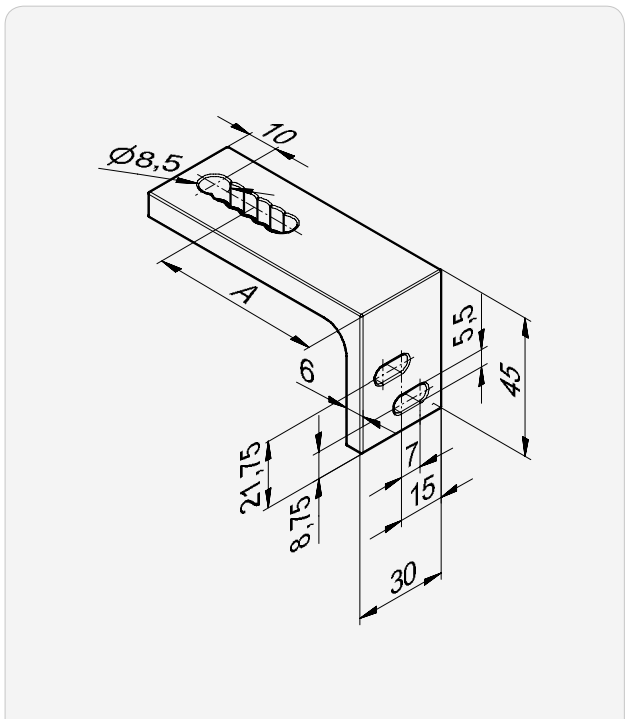

A
45...70*

* in 5 mm steps

►► Cable fastenings

Tensioning bracket 75–130 for type S

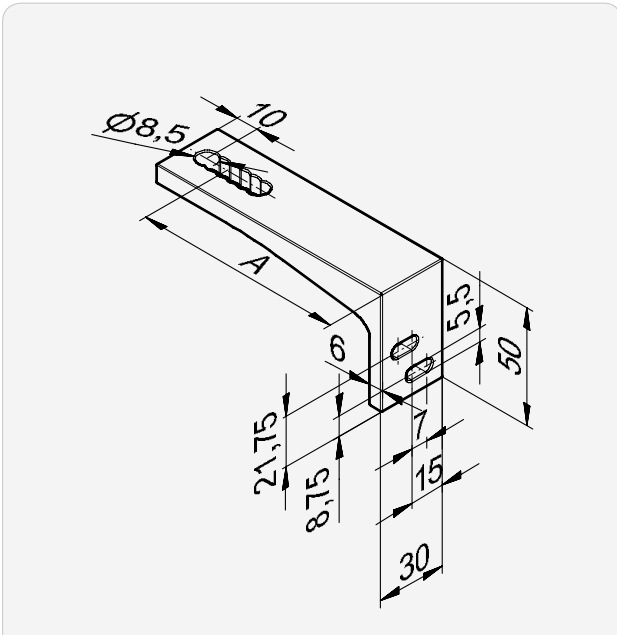

A

75...100*

105...130*

Tensioning bracket 135–190 for type S

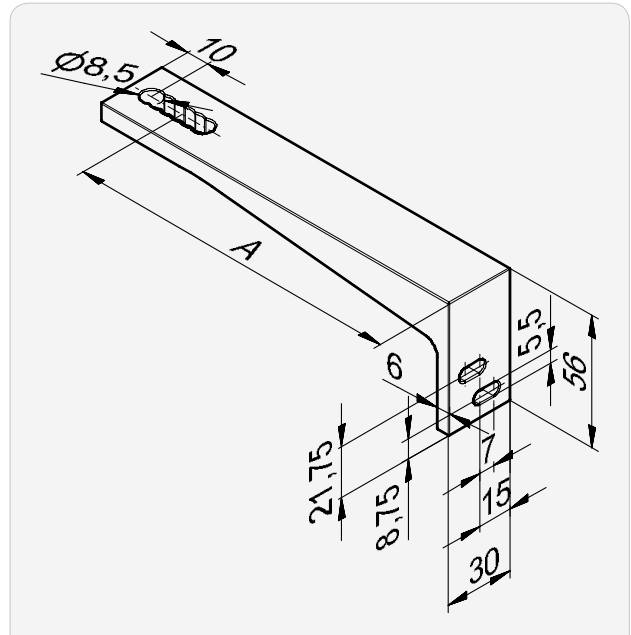

A

135...160*

165...190*

* in 5 mm steps

NU Windowsill installation

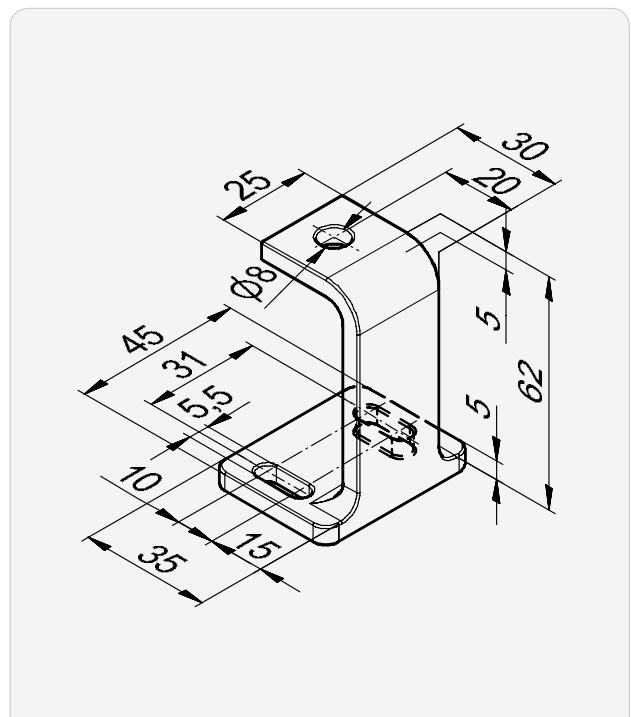
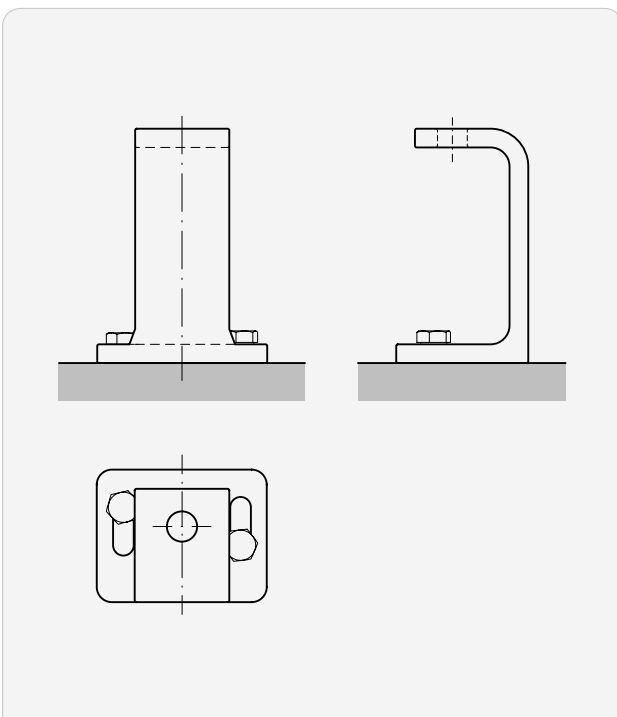

Connected systems

System width

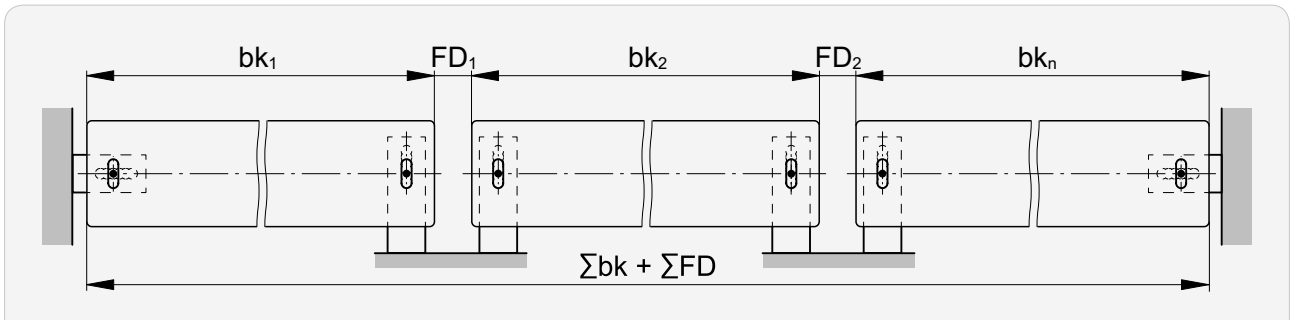

Distance between guides FD

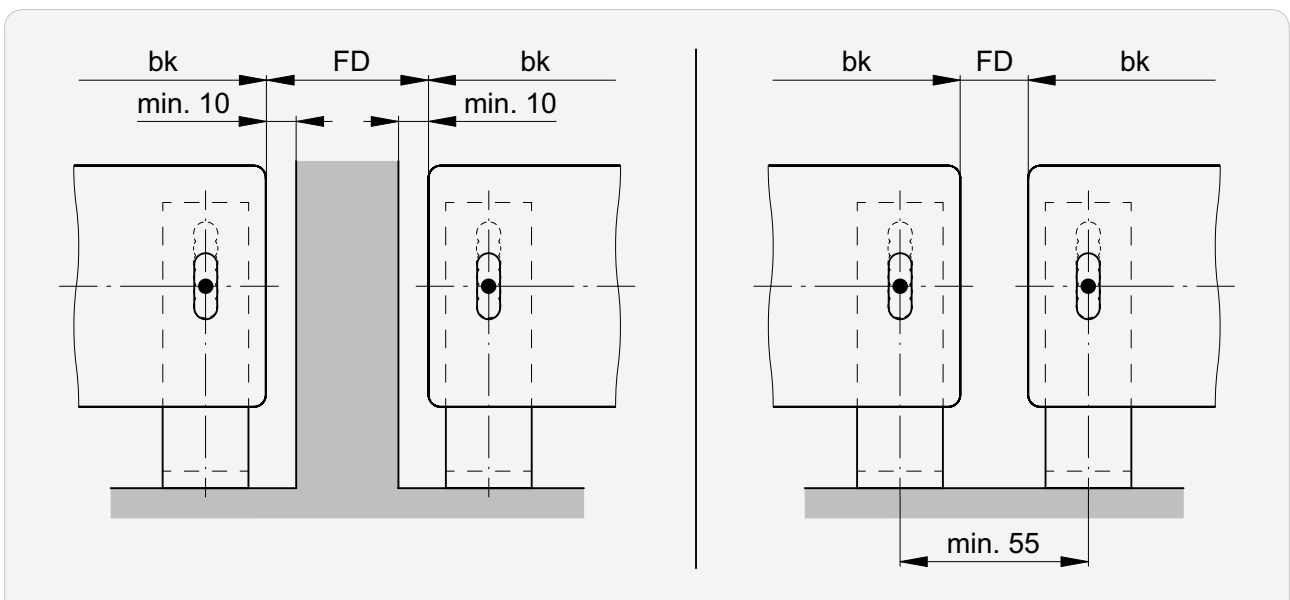

FD min.	FD max.
15	1000

►► Connected systems

Drive position

Gearbox

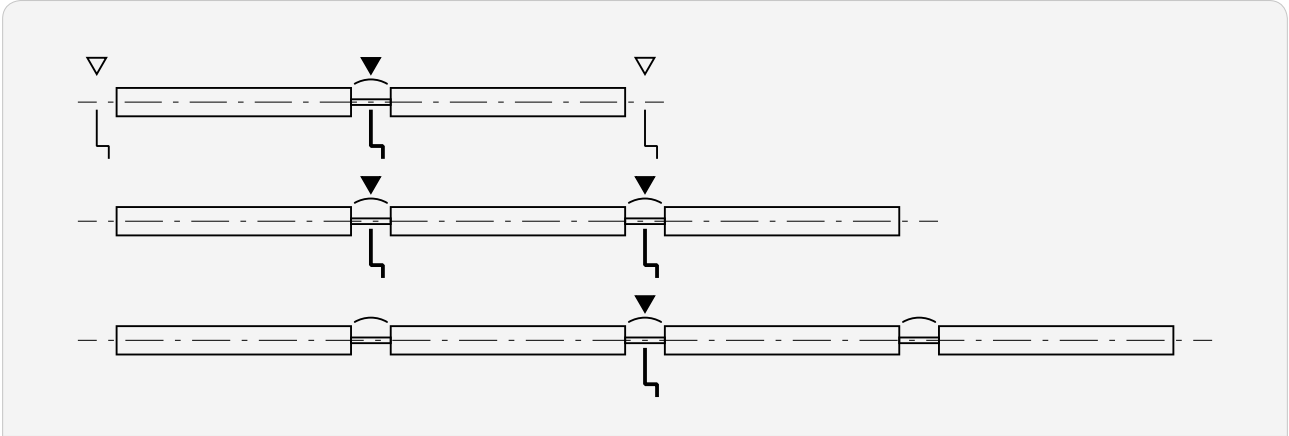

Motor

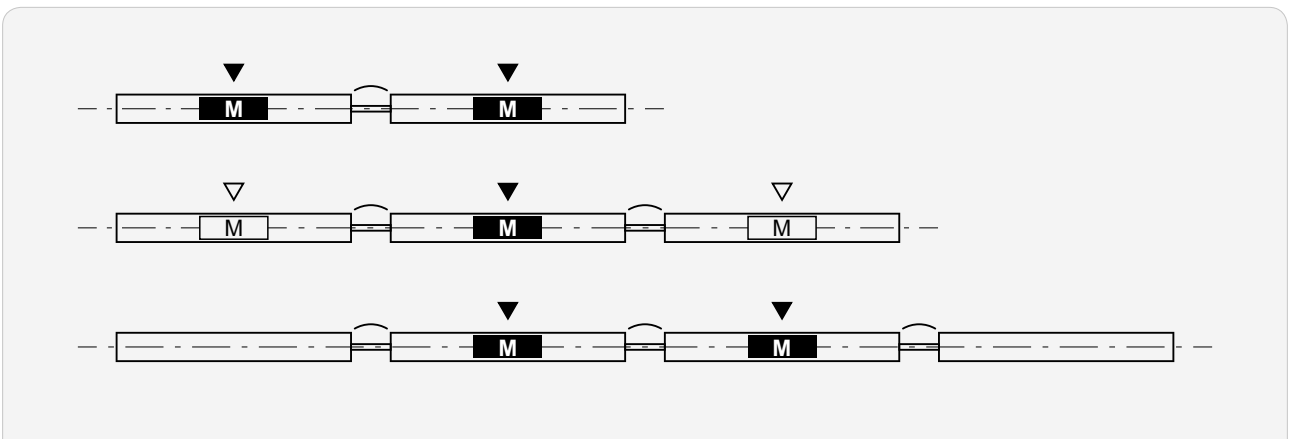

▼ Standard drive position

▽ Possible drive position

Opening for connected blinds

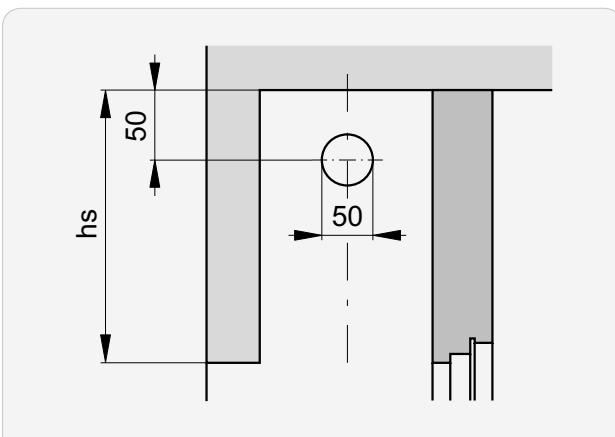

Solomatic® II

Limit dimensions Solomatic® II	240
Limit dimensions Solomatic® II Box	240
Built-in system	241
Built-in system with cover	243
Installation system with Box	245
Header dimensions Heights of package	247
Slat profiles	248
End rails	248
Beginning distance Slot spacing	249
Housing fastening	250
Number of box supports	252
Fixation for box base profile	253
Technical data of motors	254
Options	255

Rail guide

Guide rails	256
Sections Details	257
Sections for crank drive (MBMA)	260
Vertical connections Standard motor position	261
Guide rail installation (principle)	266
Guide rail fastenings (principle)	268
Guide extension and facet	276
Guide rail cut-outs in windowsill area	279
Guide rail end for suspended guide rails	281
Installation window	282
Fastening points	283
Connected systems	287

Cable guide

Cable guide	289
Sections Details	289
Sections for crank drive (MBMA)	291
Additional cables	292
Vertical connections Standard motor position	293
Cable fastenings	298
Connected systems	300



Limit dimensions Solomatic® II

Single blind

Operation	Width min. (bk)	Width ² max. (bk)	Height min. (hl)	Height max. (hl)	Surface ³ max. [m ²]
Crank drive	500*	4500	440	4500 4000 ⁵	11
Motor drive	600 630 ⁵				15

Connected systems

Operation	Width ² max. (bk)	Blinds max.	Surface ³ max. [m ²]
Crank drive ¹	10 000	4	11
Motor drive ⁴			24

The guide distance **FD** must be at least 15 mm with cable guide.

¹ A max. of 2 blinds may be connected on each side of the gearbox.

* with MBMA– on request (depending on gear position)

Limit dimensions Solomatic® II Box

Single blind

Operation	Width min. (bk)	Width ² max. (bk)	Height min. (gh)	Height max. (gh)	Surface ³ max. [m ²]
Motor drive	600 630 ⁵	4500	605 ⁶ 735 ⁷	4845 ⁶ 4760 ⁷ 4000 ⁵	11

Connected systems

Operation	Width ² max. (bk)	Blinds max.	Surface ³ max. [m ²]
Motor drive ⁴	10 000	4	24

² For buildings and high-rise structures, which are exposed to high winds, this maximum value should be decreased as required. Also see wind classes data sheet.

³ If crank drive is in slat area: maximum surface area and crank position available on request.

⁴ For 3 or 4 blinds, the motor should be positioned in the center.

⁵ Radio motor Geiger AIR

⁶ Solomatic® II Box guide rail

⁷ Solomatic® II Box cable guide

Built-in system

Vertical section: Guide rail conventional

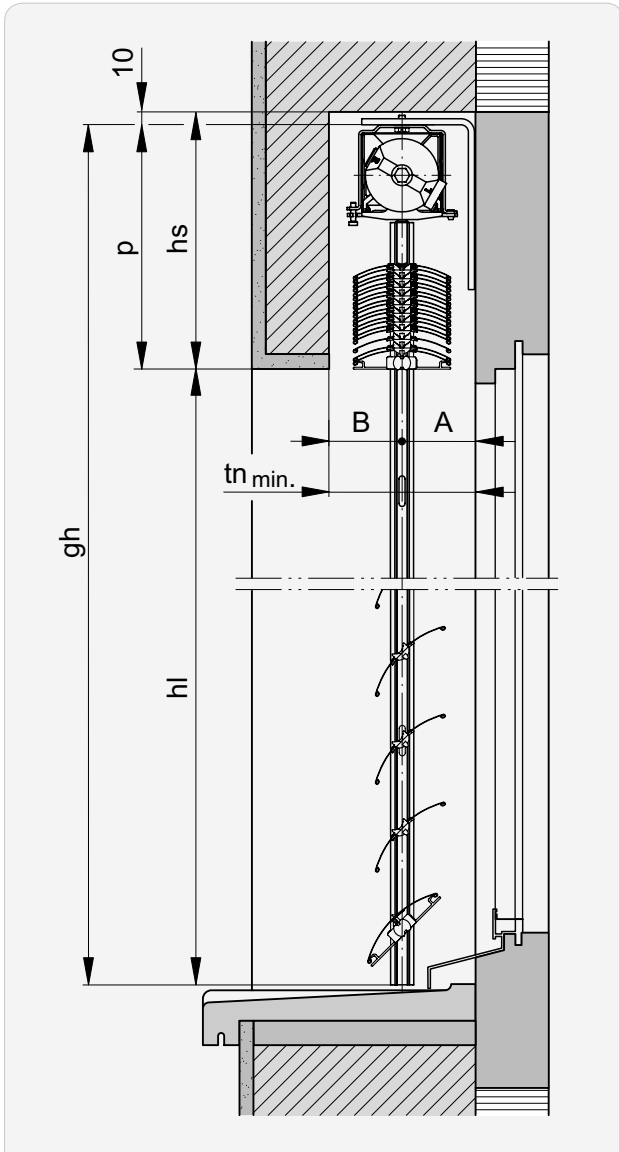

Vertical section: Guide rail Fix-L

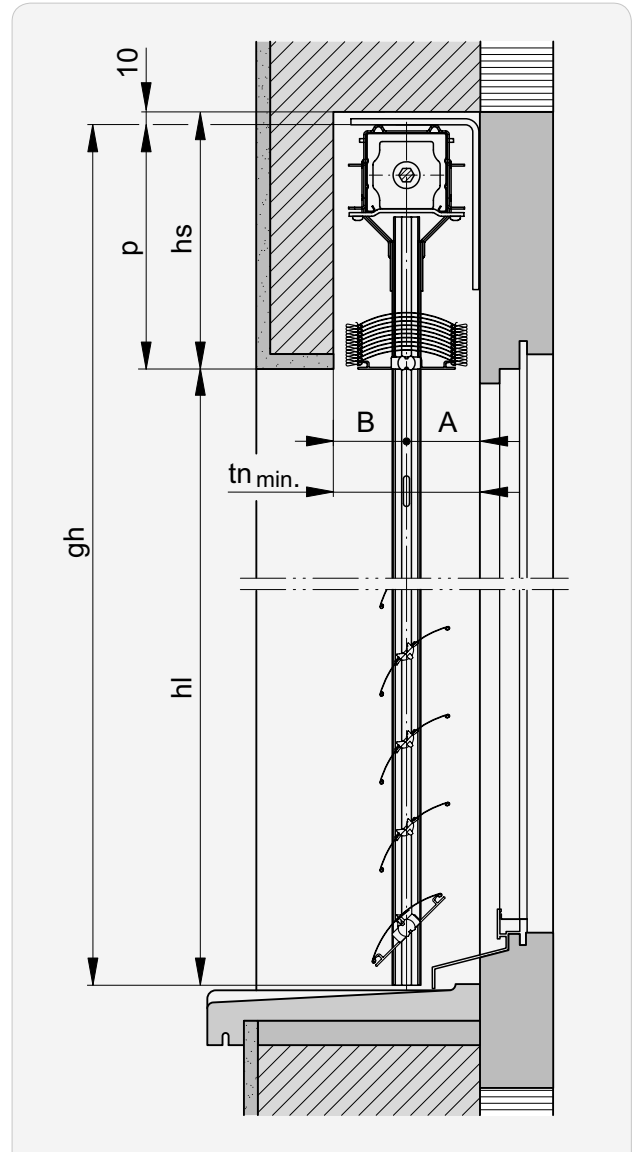

Horizontal section: Guide rail conventional

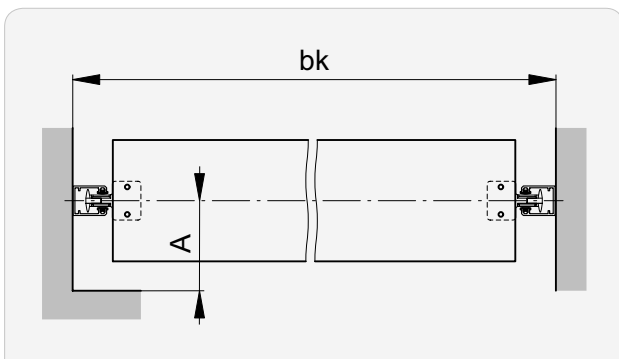

Horizontal section: Guide rail Fix-L

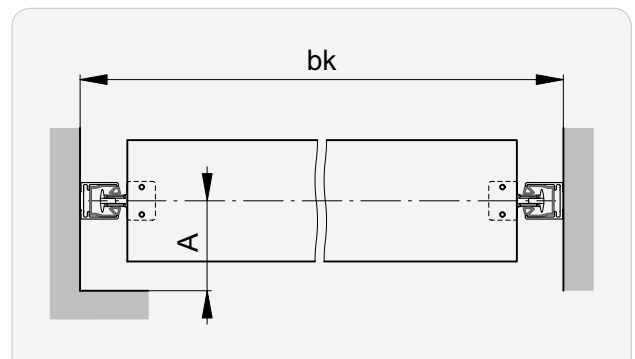

►► Built-in system

Vertical section: Guide rail Fix

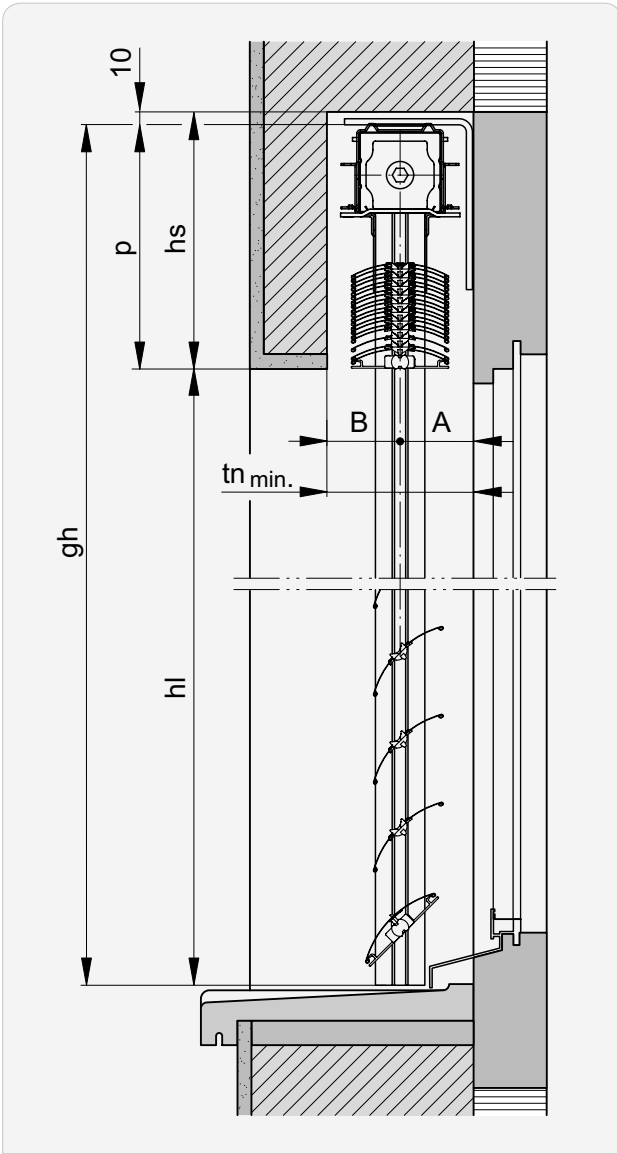

Vertical section: Cable guide

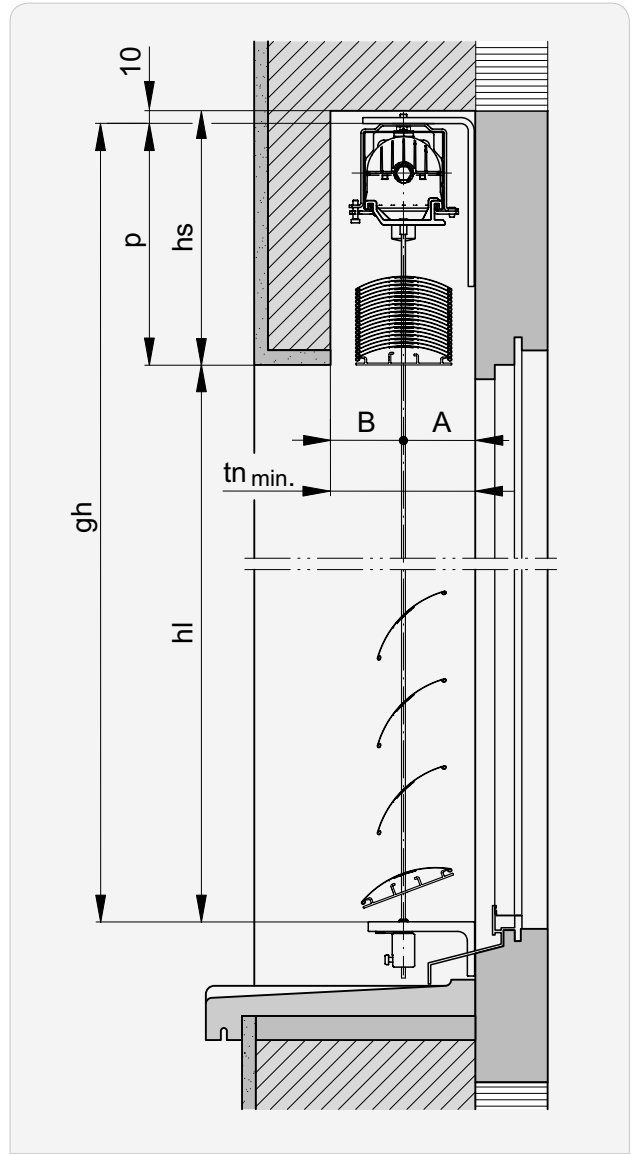

Horizontal section: Guide rail Fix

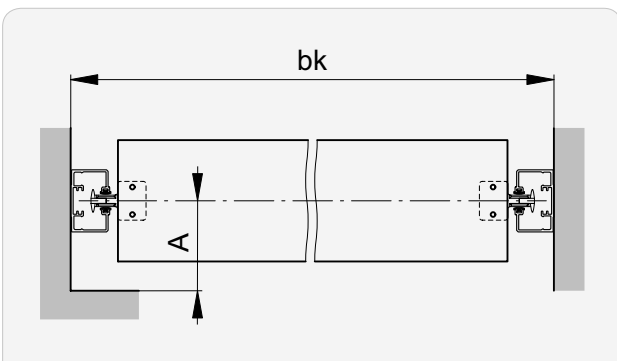

Horizontal section: Cable guide

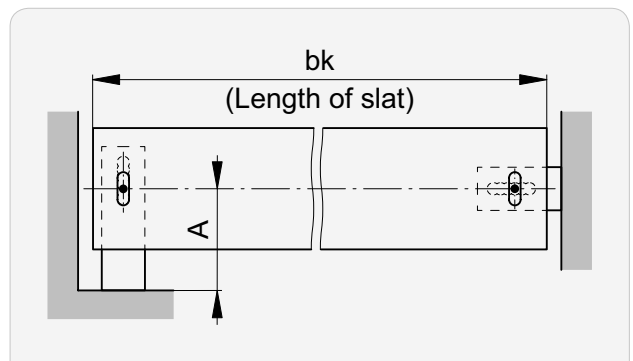

Built-in system with cover

Vertical section: Guide rail conventional

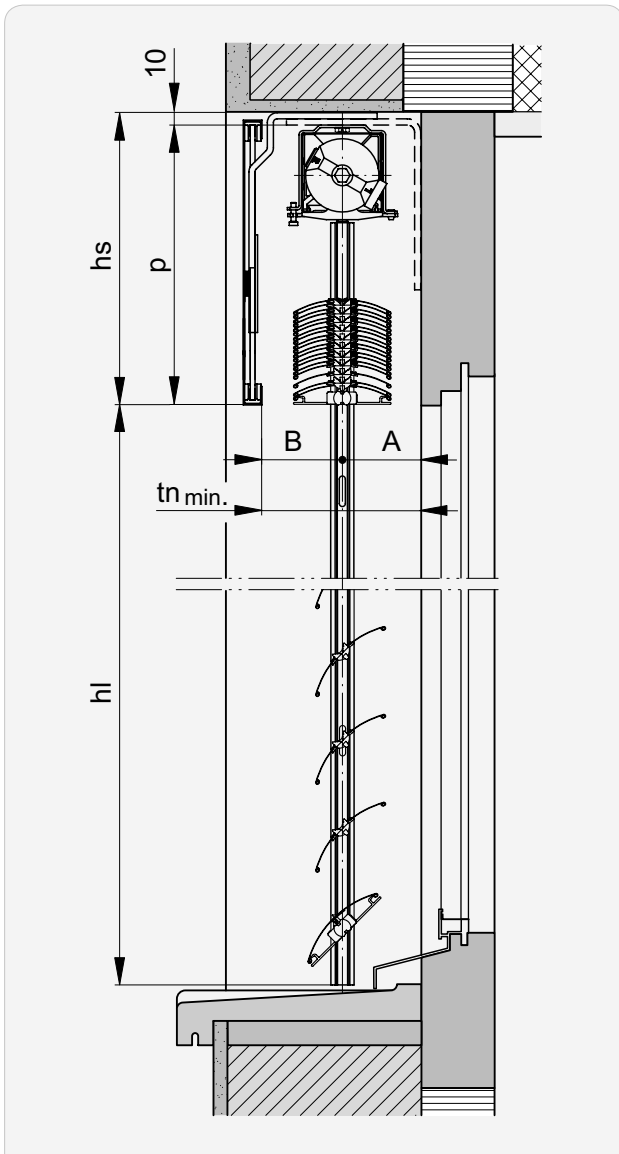

Vertical section: Guide rail Fix-L

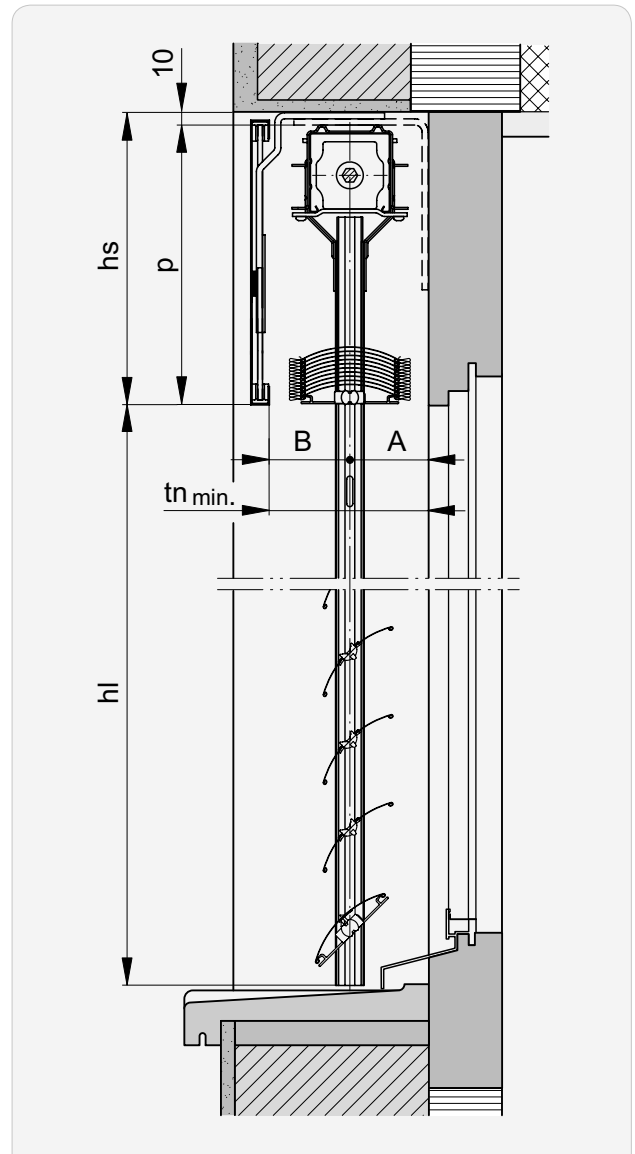

Horizontal section: Guide rail conventional

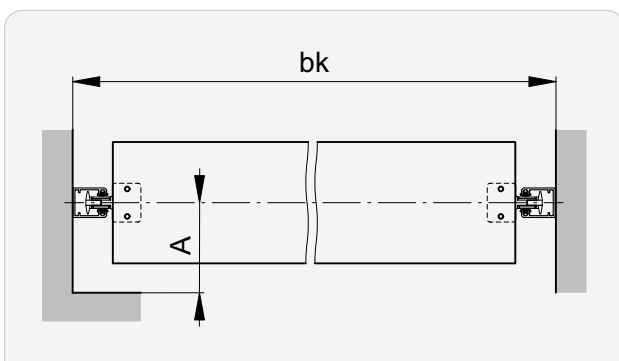

Horizontal section: Guide rail Fix-L

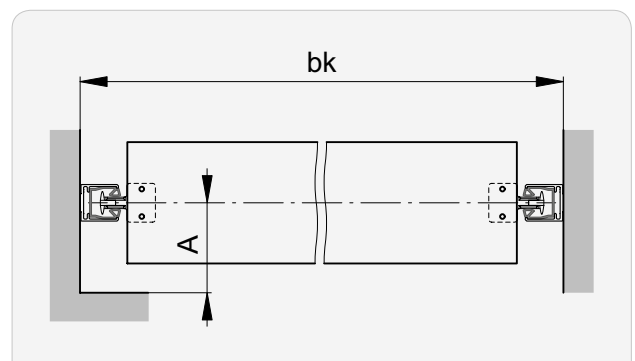

►► Built-in system with cover

Vertical section: Guide rail Fix

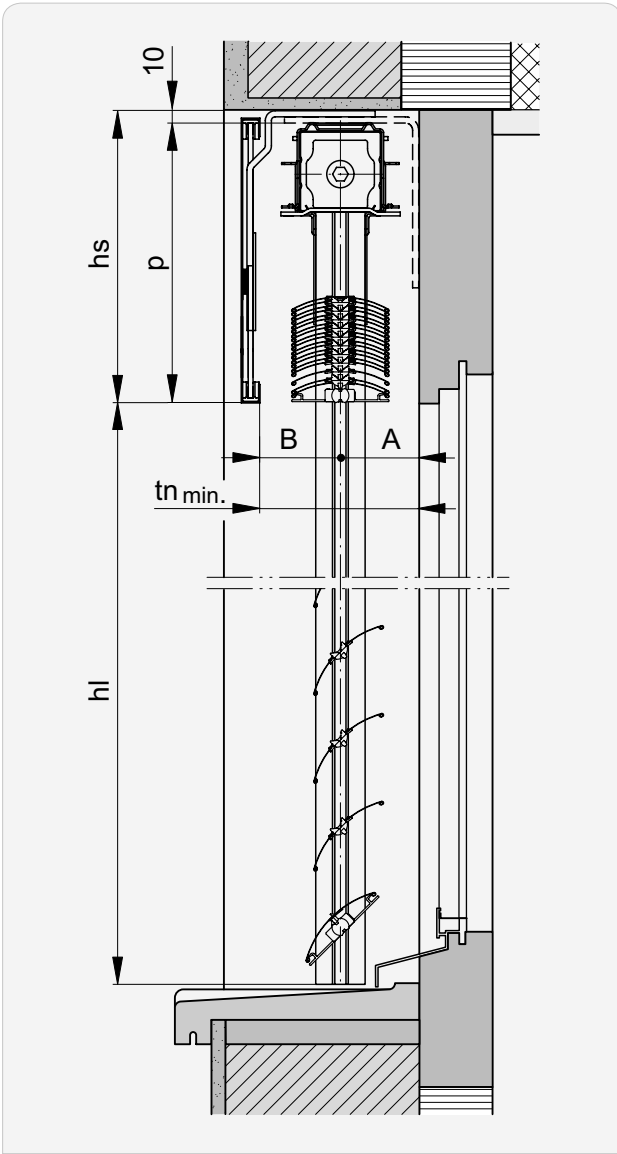

Vertical section: Cable guide

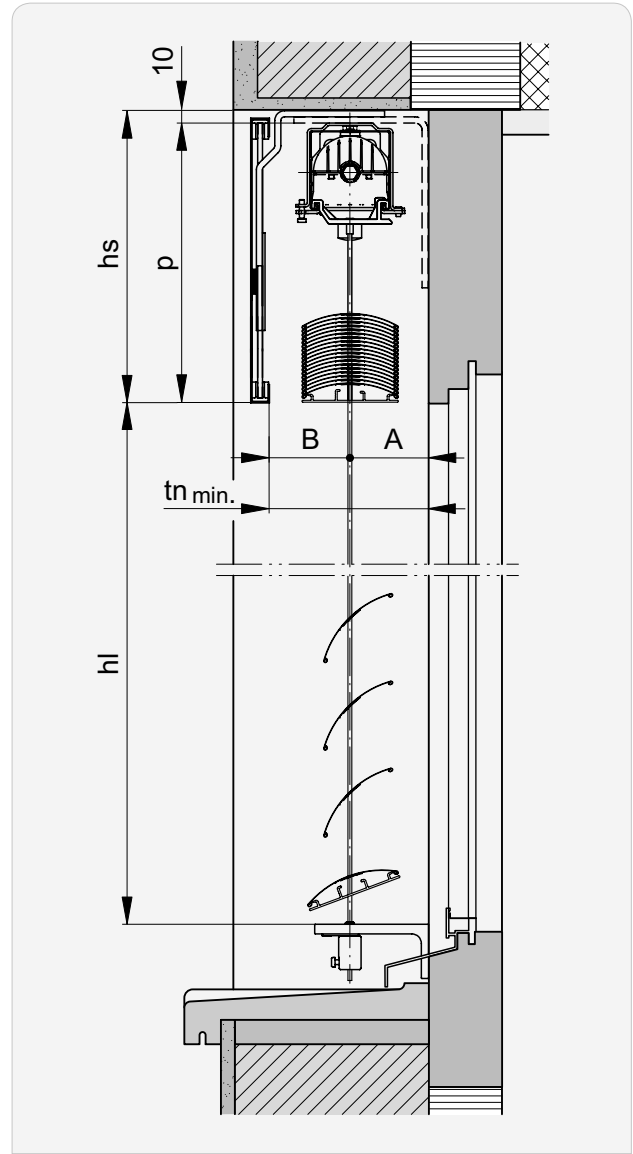

Horizontal section: Guide rail Fix

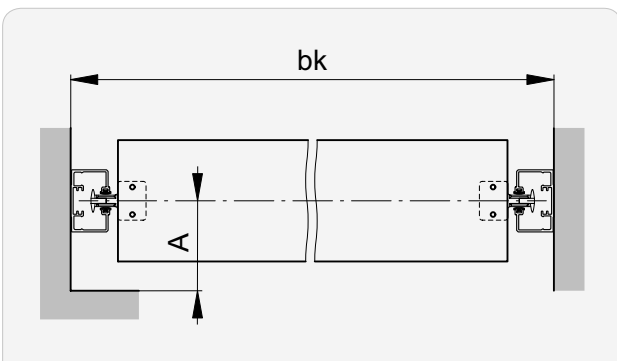

Horizontal section: Cable guide

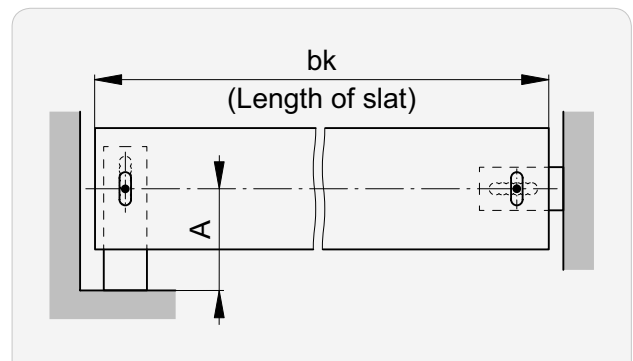

Installation system with Box

Vertical section: Guide rail conventional

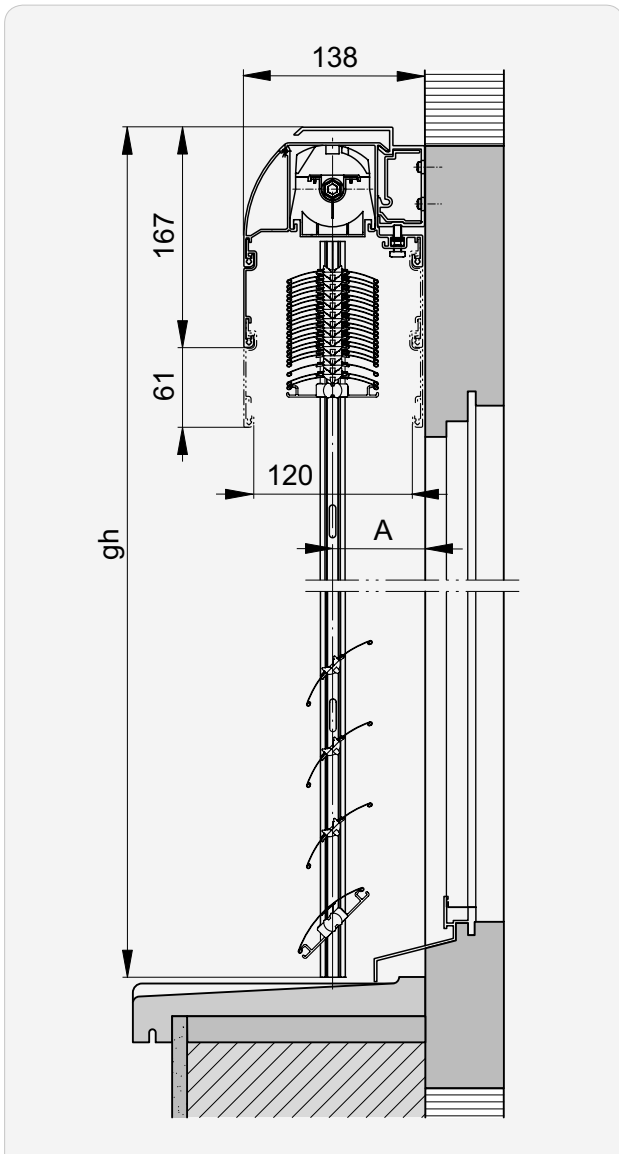

Box round | Slat package covered (standard)

Vertical section: Cable guide

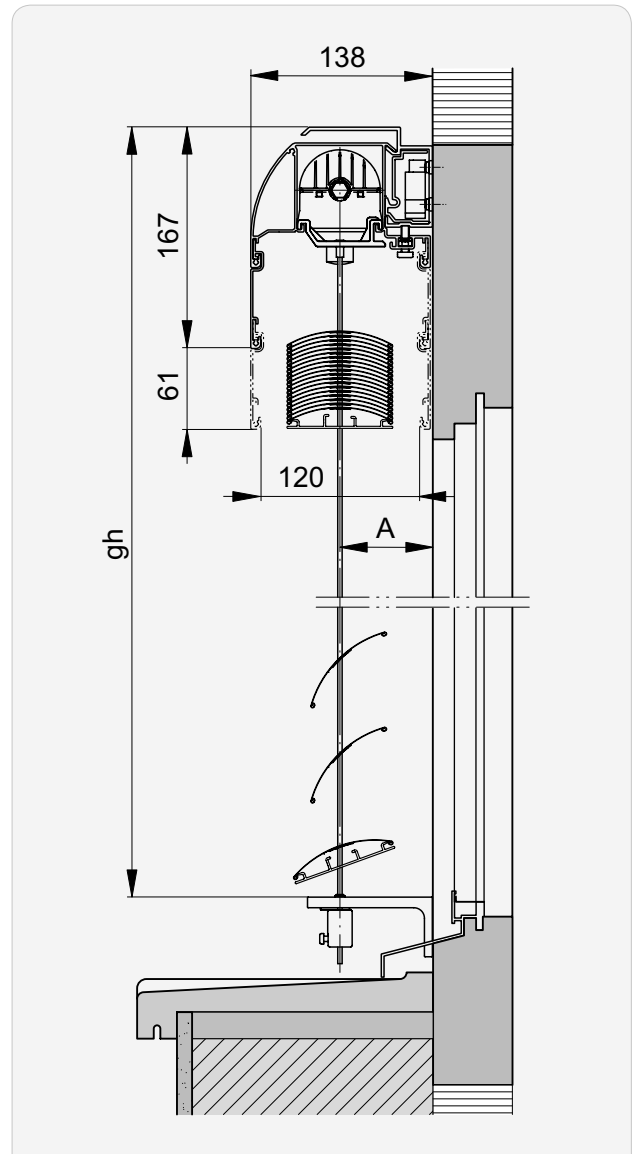

Box round | Slat package covered (standard)

Horizontal section: Guide rail conventional

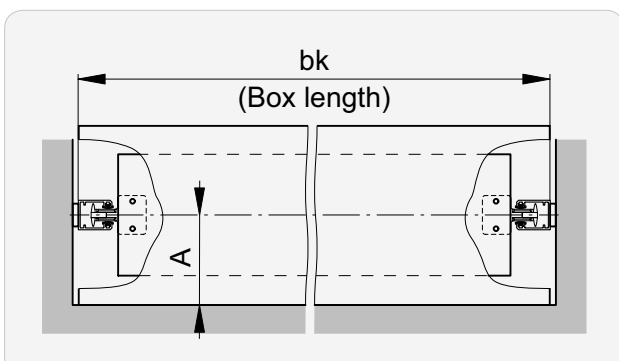

Horizontal section: Cable guide

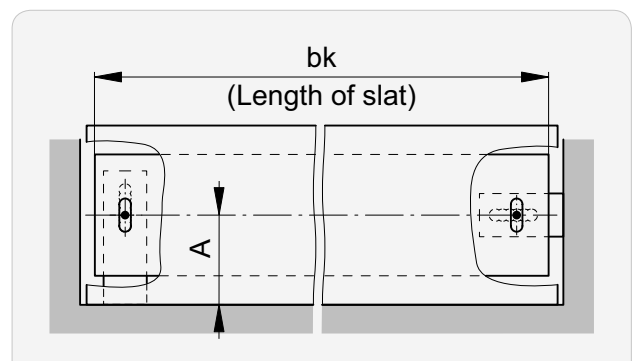

►► Installation system with Box

Vertical section: Guide rail conventional

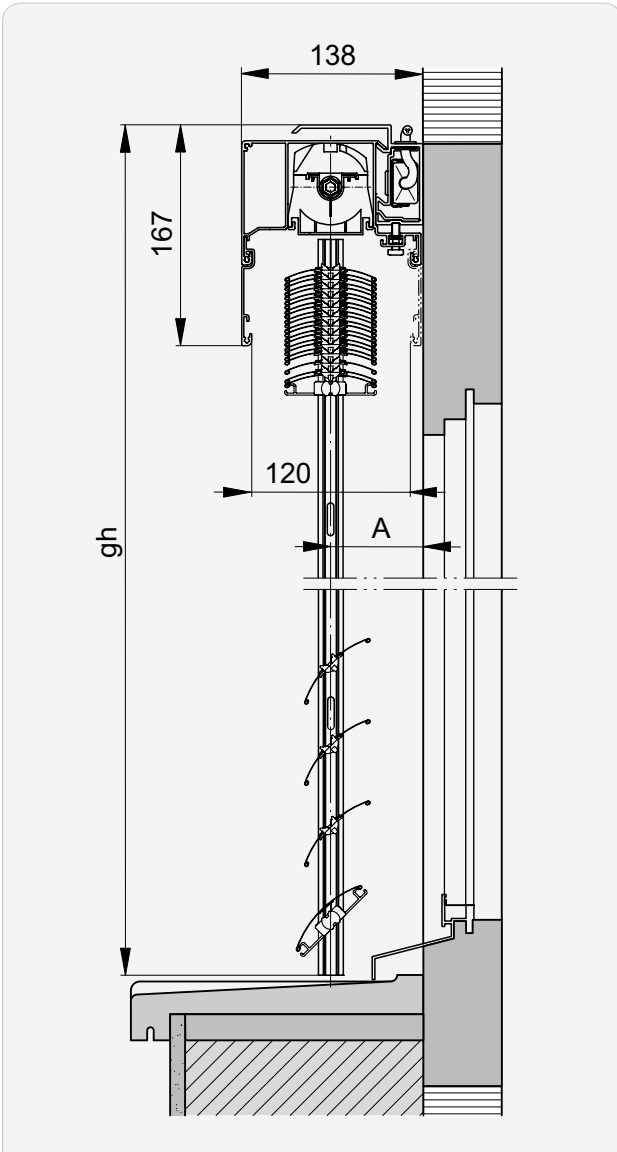

Box square | Slat package visible

Vertical section: Cable guide

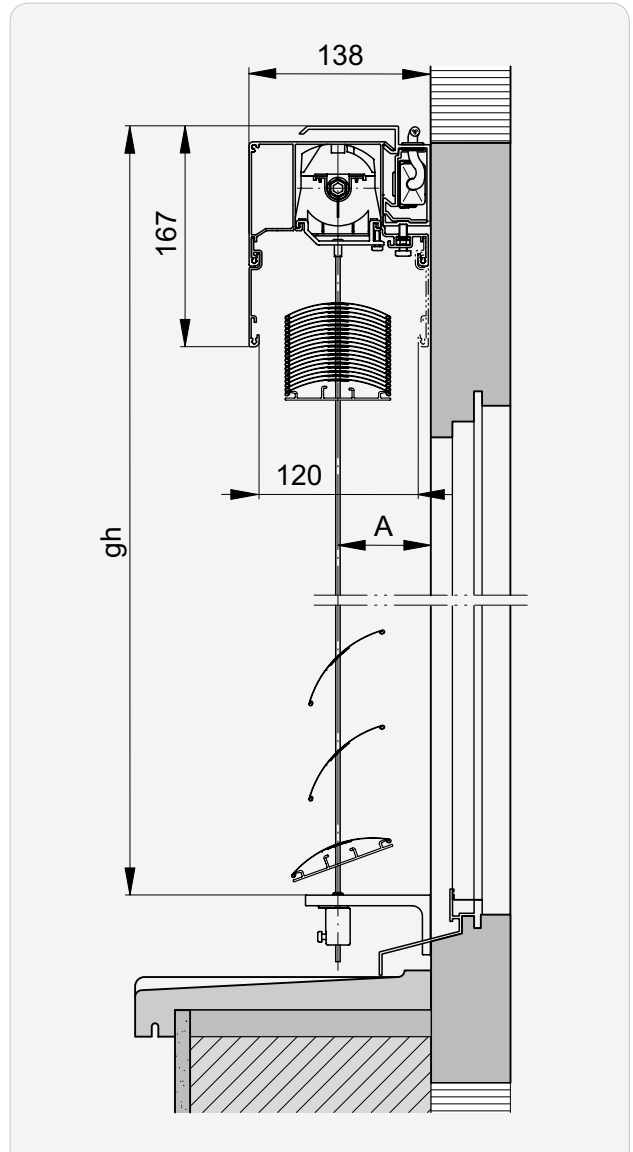

Box square | Slat package visible

Horizontal section: Guide rail conventional

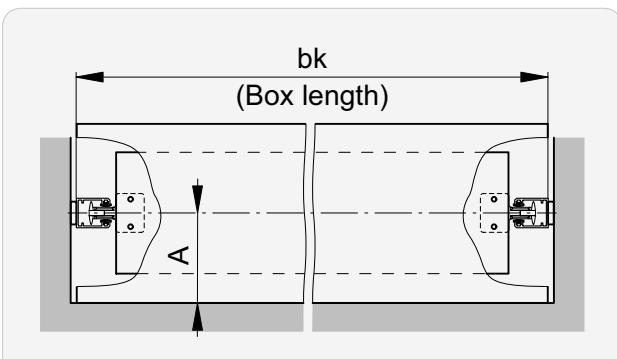

Horizontal section: Cable guide

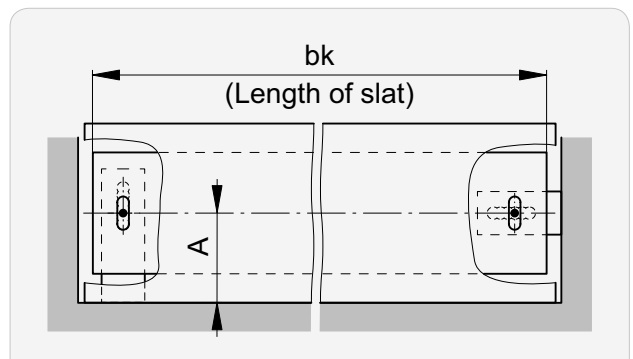

Header dimensions | Heights of package

Solomatic® II 70

hl →l	P min.	hs ¹	hl →l	P min.	hs ¹
1000	170	180	3200	300	310
1200	185	195	3400	315	325
1500	200	210	3500		330
1700	215	225	3700	330	340
2000	230	240	4000	345	355
2200	245	255	4200	360	370
2500	260	270	4400	375	385
2700	275	285	4500		390
3000	285	295			

Solomatic® II 80

hl →l	P min.	hs ¹	hl →l	P min.	hs ¹
1000	175	185	3000	270	280
1100	185	195	3200	280	290
1500	195	205	3500	290	300
1700	210	220	3700	305	315
2000	220	230	4000	315	325
2200	230	240	4200	325	335
2500	245	255	4500	340	350
2700	255	265			

Version	tn min.	A	B
Built-in system	100*	50	50
Installation system (Box)		70	

Version	tn min.	A	B
Built-in system	120*	60	60
Installation system (Box)		70	

¹ With gearbox in slat area: **hs + 20**.

Solomatic® II Reflect: **hs + 5**.

Solomatic® II Box: **hs + 7**.

* + possible addition for protruding weatherboard or doorknobs.

Valid for installation of Solomatic® II conventional and Fix and also Solomatic® II with tensioning cable guide.

i Header dimensions are approximate values which may exhibit **negative or positive deviations** depending on the technical circumstances. **A dimensional tolerance of ±5 mm** is observed for the header height.

Slat profiles

Solomatic® II 70

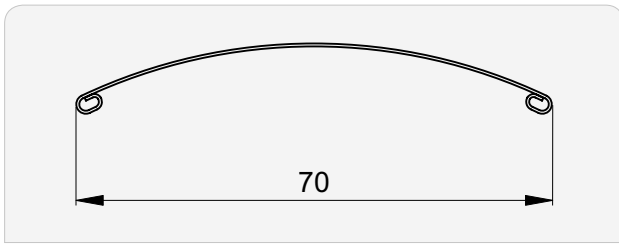

Solomatic® II 80

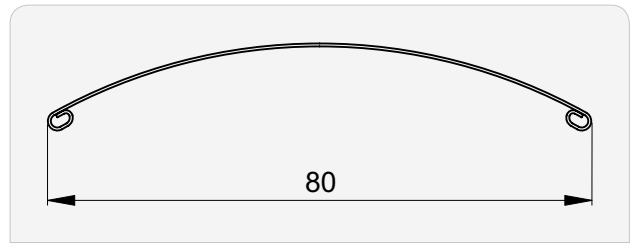

End rails

Solomatic® II 70

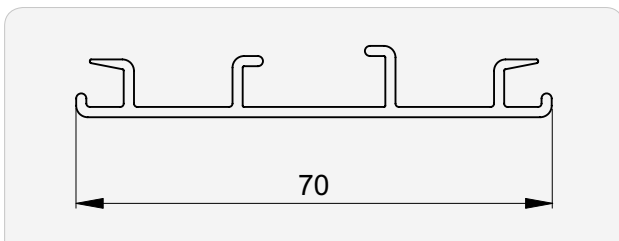

Solomatic® II 80

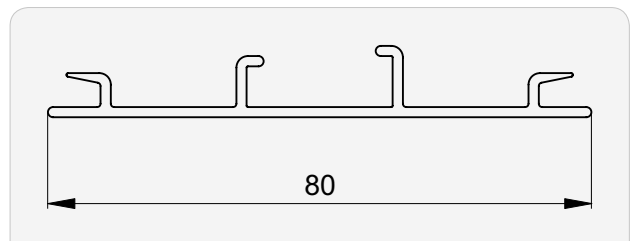

Beginning distance | Slot spacing

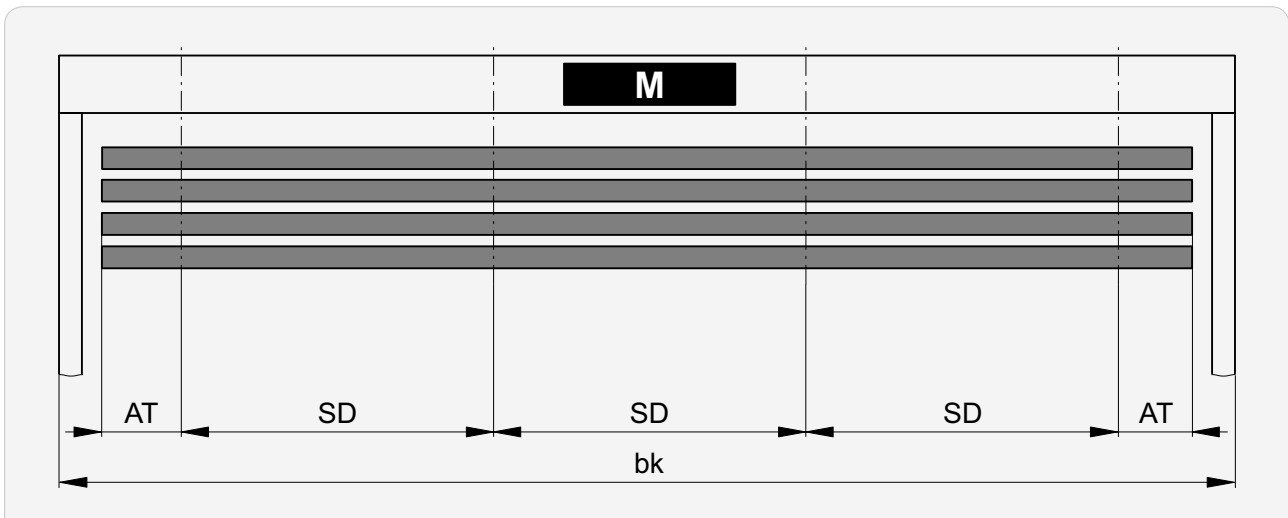

bk	AT min.		SD min.	SD max.
≤ 610	Conventional	50		
	Fix	60		
	Fix connected	80		
	Cable	67		
611 ... 1250	Conventional		250*	1000*
	Fix	100		
	Fix connected			
611 ... 1230	Cable	117		
> 1250	Conventional			
	Fix	200		
	Fix connected			
> 1230	Cable	217		

* Standard slot spacing machine fabrication

Deviations from the standard are possible when:

Deviation	Correction
MBMA+ < 40	AT
Support loading too high	AS
Slot spacing < 250	AT + AS
With motor	AT + AS

AT Beginning distance
Distance from beginning of slot to centre of bearing

SD Slot spacing
Distance from centre of bearing (slot) to centre of bearing (slot)

Housing fastening

At top

NO

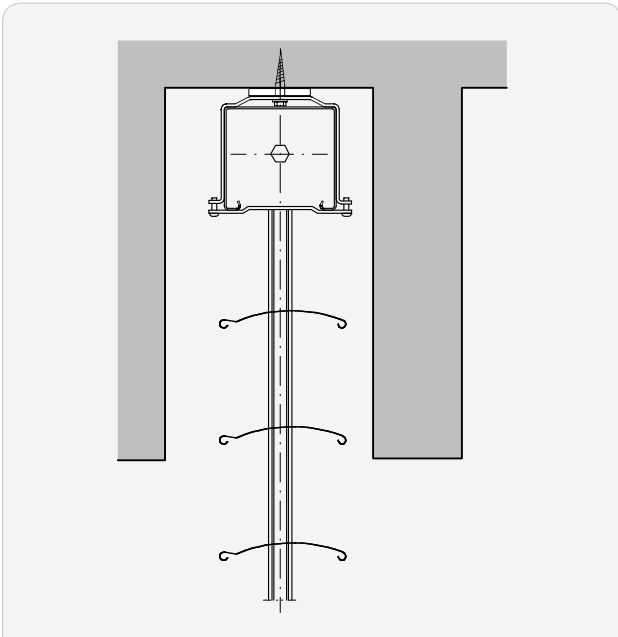

Box support

KT

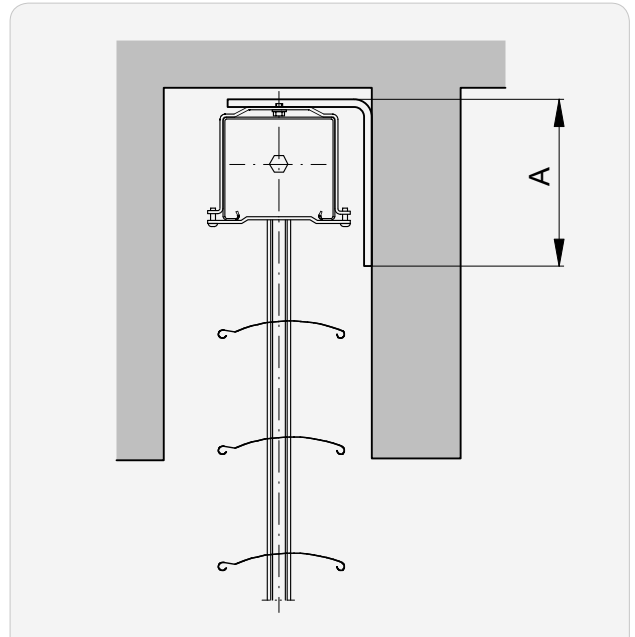

Box support for type KT, for small headers*

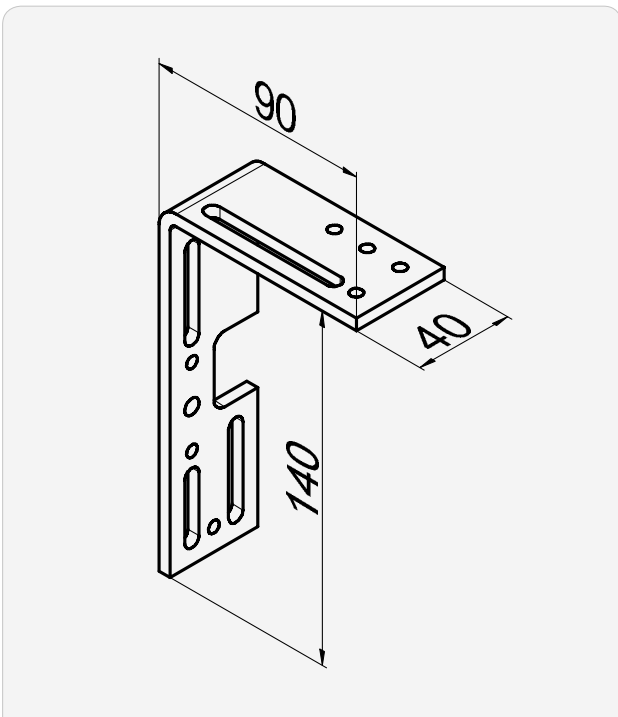

A
140

* Header 100

Box support for type KT

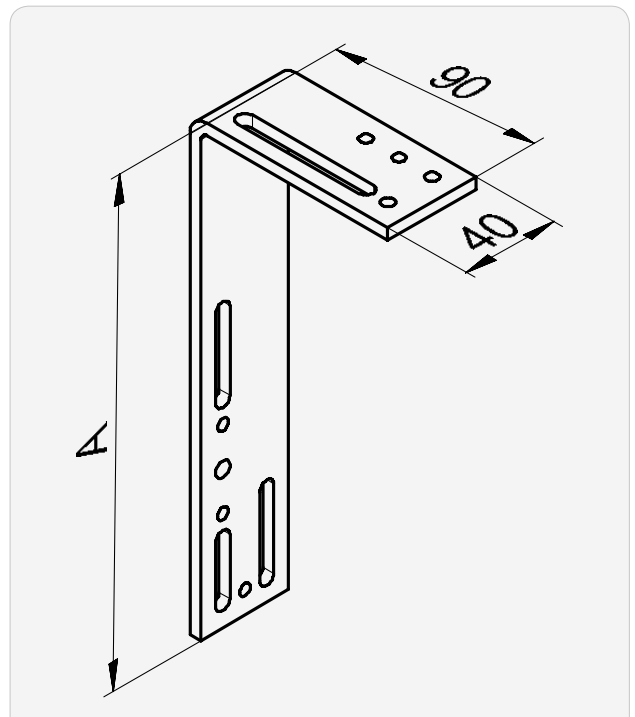

A
200
260

►► Housing fastening

Double box support

DR

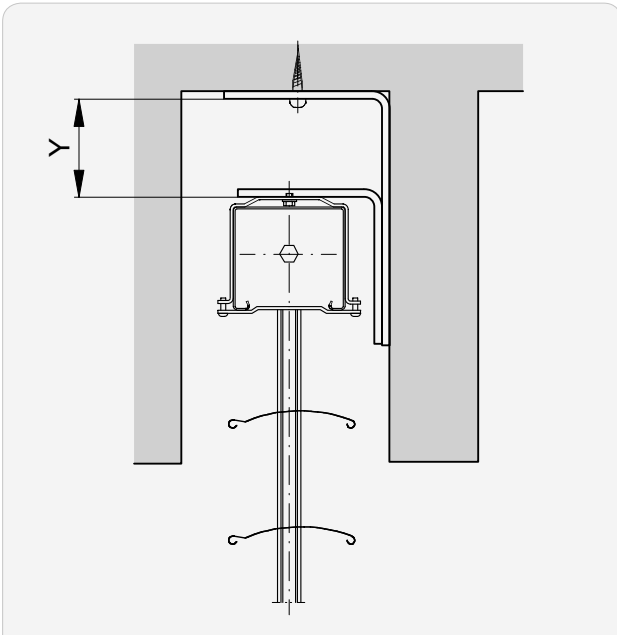

Gallery clip

GB

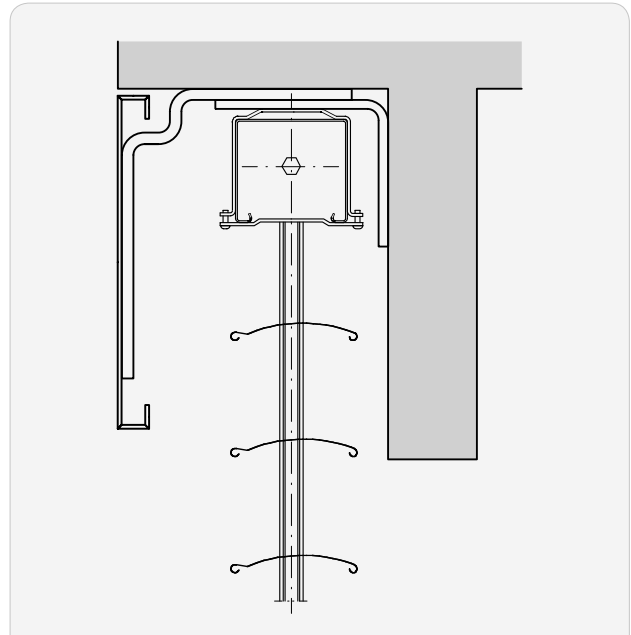

Double box support for type DR

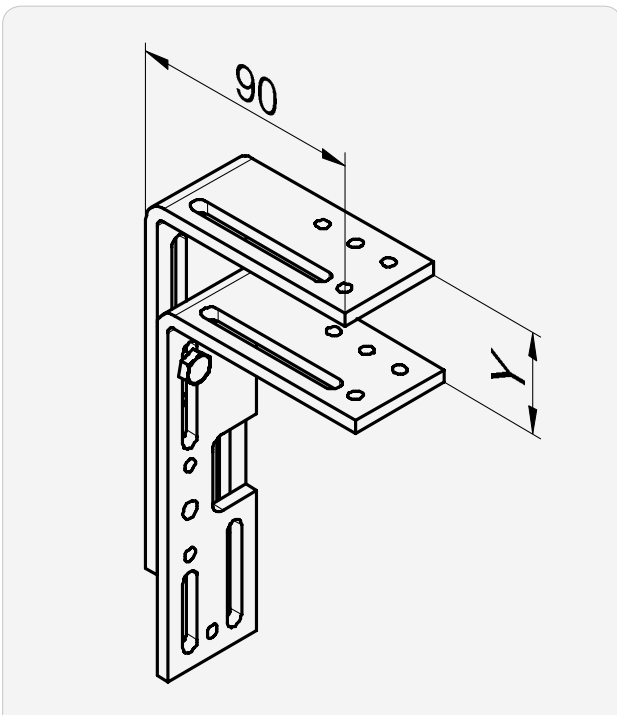

Gallery clip for type GB

i See additional documentation:
Short manual "Covers"



[↓ Covers](#)



Y

10... 75

75... 135

135... 200

Number of box supports**Conventional and cable guides**

bk	Quantity
≤ 2000	2
2001 ... 3000	3
3001 ... 4000	4
> 4000	5

Fix guides | Additional fastenings

bk	Quantity
≤ 2500	0
2501 ... 3500	1
> 3500	2

Fixation for box base profile

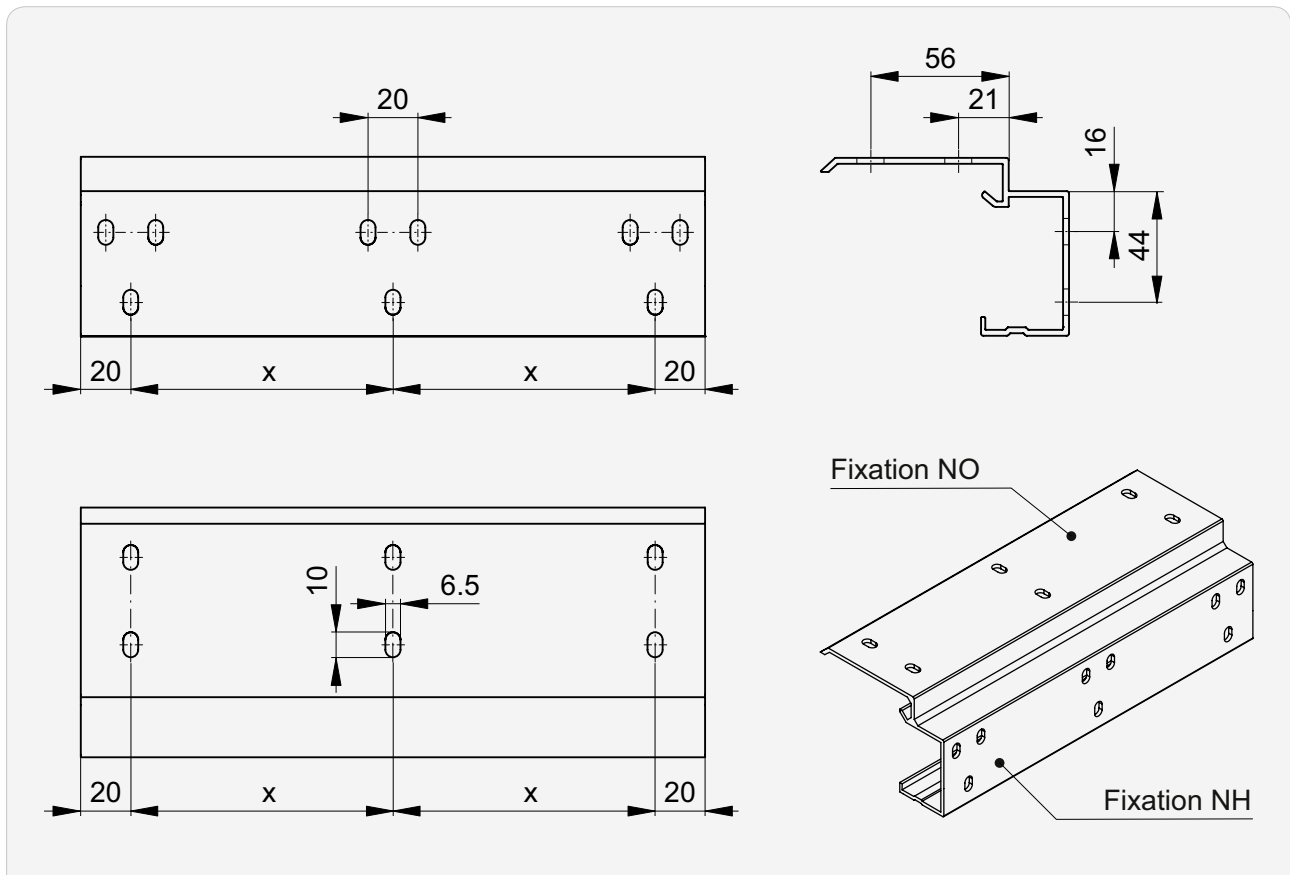

Number of fixation points

bk	Number of fixation points
≤ 2000	2
2001 ... 3000	3
3001 ... 4000	4
> 4000	5

Technical data of motors

Performance characteristics

Type	Limit switch		M [Nm]	n [1/min.]	P [W]	I [A]
	Type	Number of				
Standard						
Elero						
ES...	06.01	mechanical	6	26	110	0.50
	09.01		9		170	0.75
EO...	20.01		20		190	1.05
ES...	06.51	mechanical	6	26	110	0.50
	09.51		9		170	0.75
EO...	20.51		20		190	1.05
Option						
Somfy						
SH...	06.01	mechanical	6	24	95	0.40
	10.01		10		110	0.65
	18.01		18		155	1.00
SW...	06.01		6		95	0.40
SI...	10.01	electronic	10	24	110	0.65
	18.01		18		155	1.00
Elero Comfort						
ECM...	06.01	electronic	6	26	115	0.50
	09.01		9		156	0.68
	06.51		3		115	0.50
	09.51		9		156	0.68
ECB...	06.01	electronic	6	26	115	0.50
	09.01		9		156	0.68
	06.51		3		115	0.50
	09.51		9		156	0.68
Geiger AIR						
GA...	06.01	electronic	6	26	93	0.40
	06.10		10		135	0.60
	06.20		20		190	0.85

I Current consumption

M Torque

n Rotational speed

P Power consumption

Options

Solomatic® II Reflect

i For glare protection at bottom and use of daylight at top.

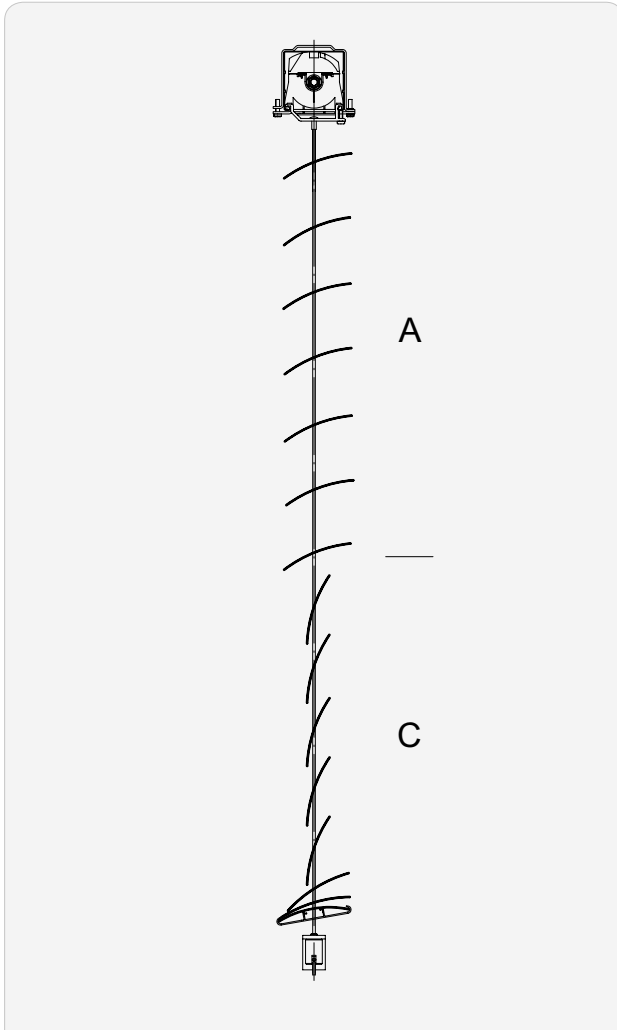

C

Standard: 1/3 from **hl**

- A** Use of daylight
- C** Glare protection

Guide rails

Type E | Single guide

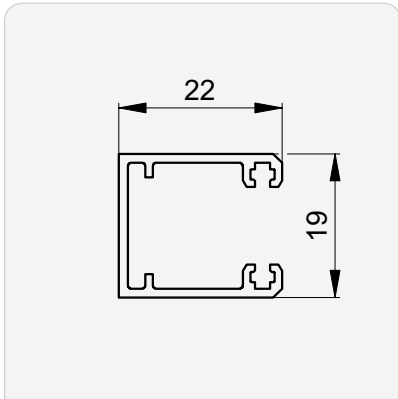

Type L | Fix guide

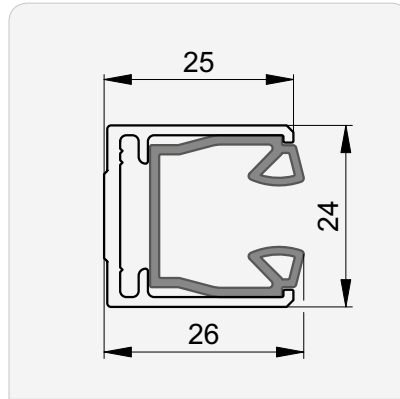

Type F | Fix guide

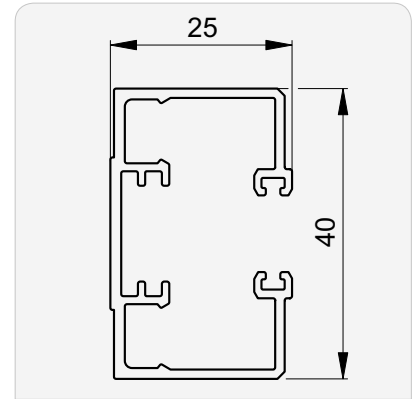

Type D | Double guide

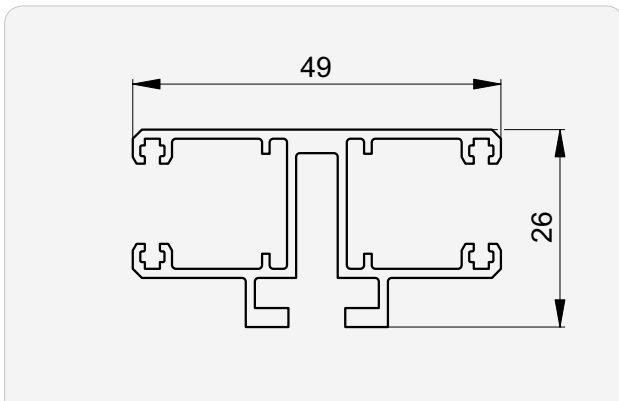

Special guide fastening required

Type C | Single guide

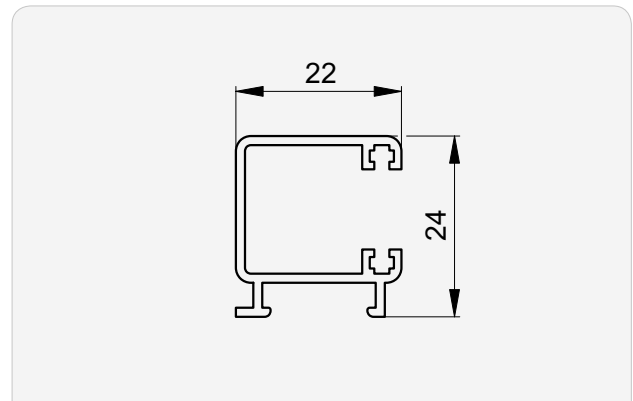

Type R | Curved double guide

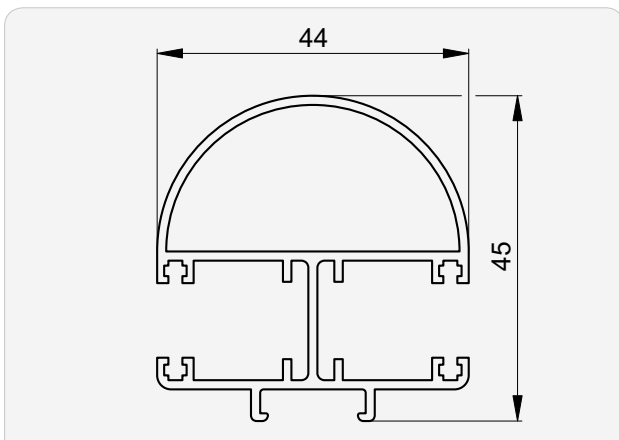

Type T | Double guide

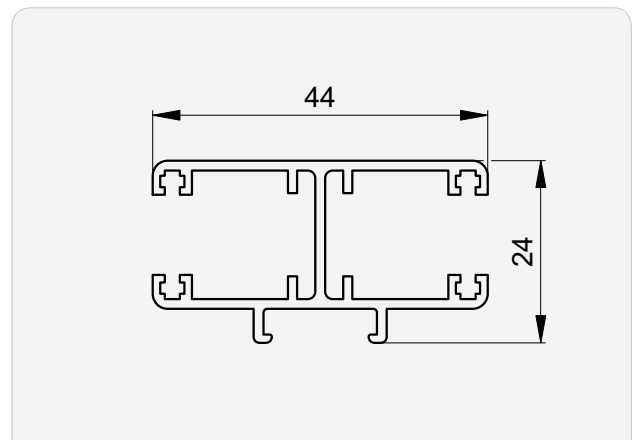

- Distance between guides **FD**..... 287
- Fastening points 283
- Guide extension and facet 276
- Guide rail fastenings 268

- Guide rail cut-outs in windowsill area 279
- Installation window 282
- Integrated guides 267

Sections | Details

Horizontal section: Guide rail conventional

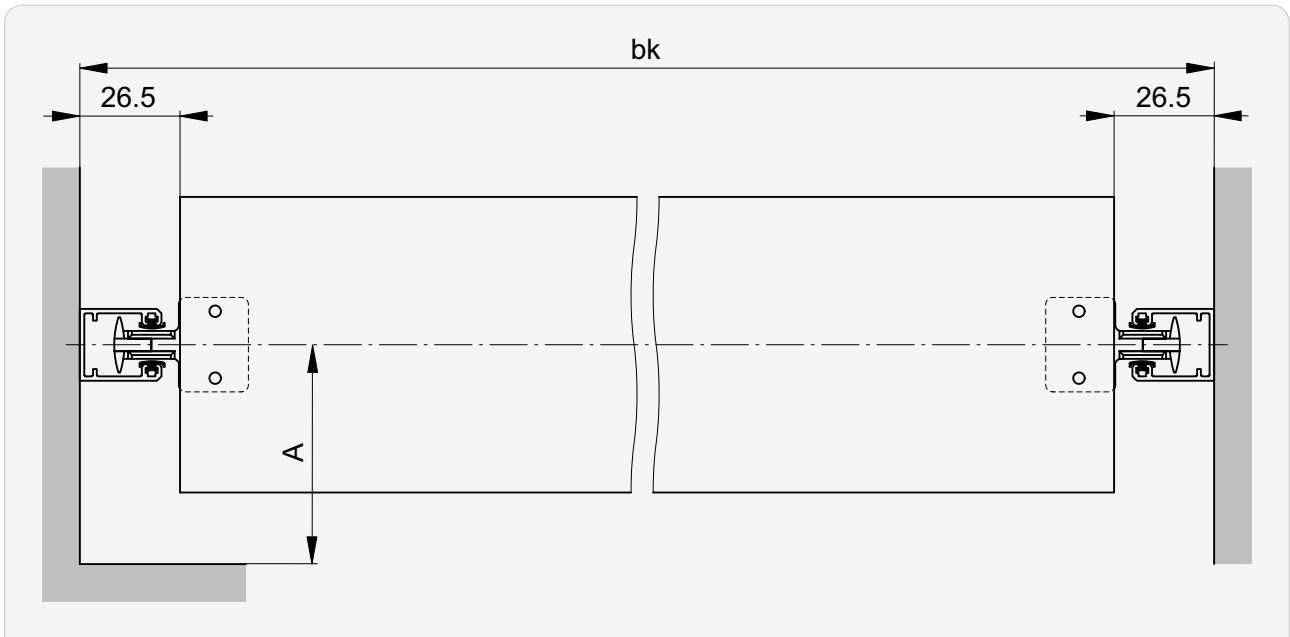

Horizontal section: Guide rail Fix-L

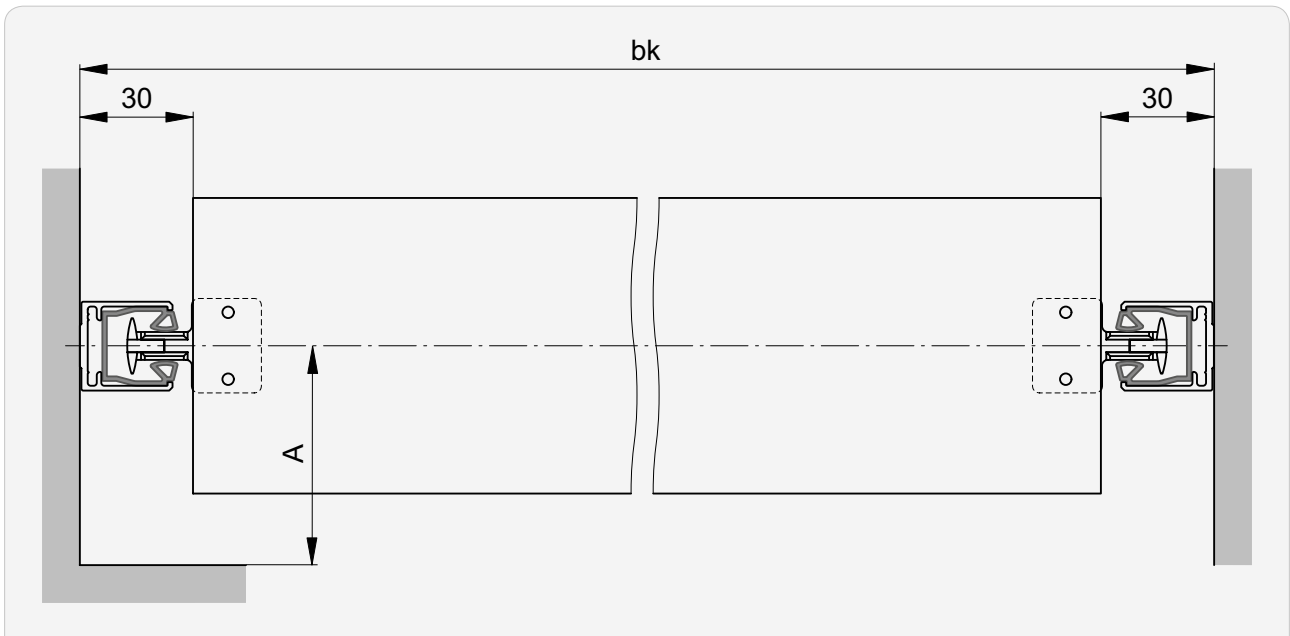

➡ Value for A 247

►► Sections | Details

Horizontal section: Guide rail Fix

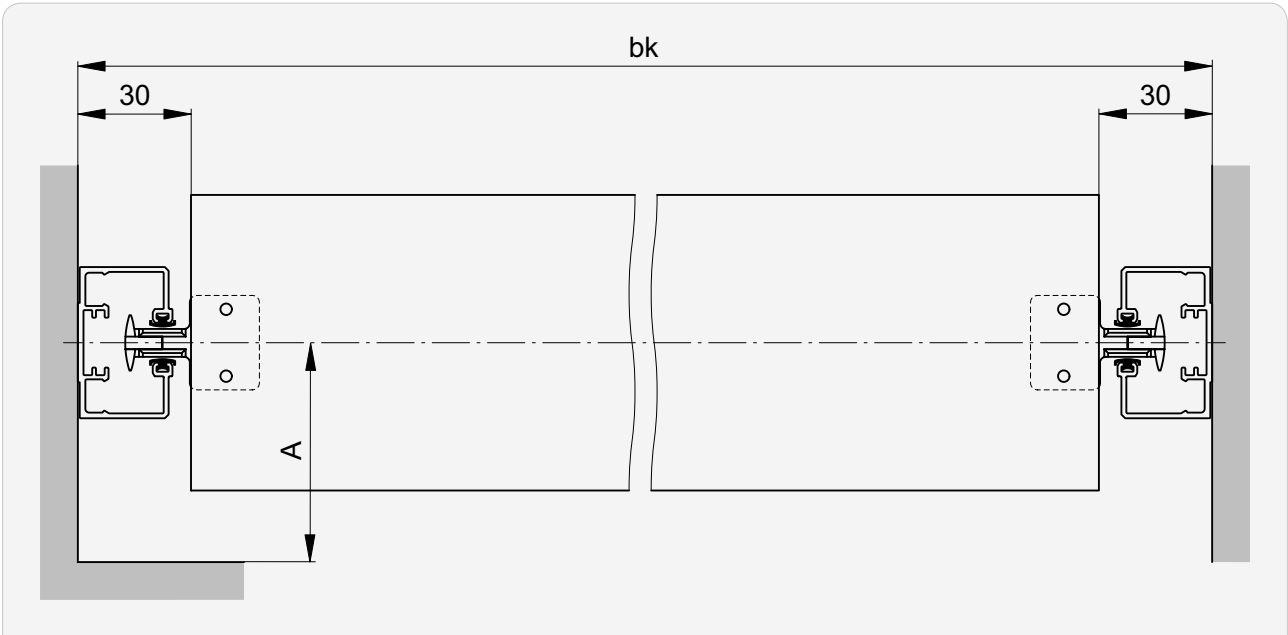

Horizontal section: Box

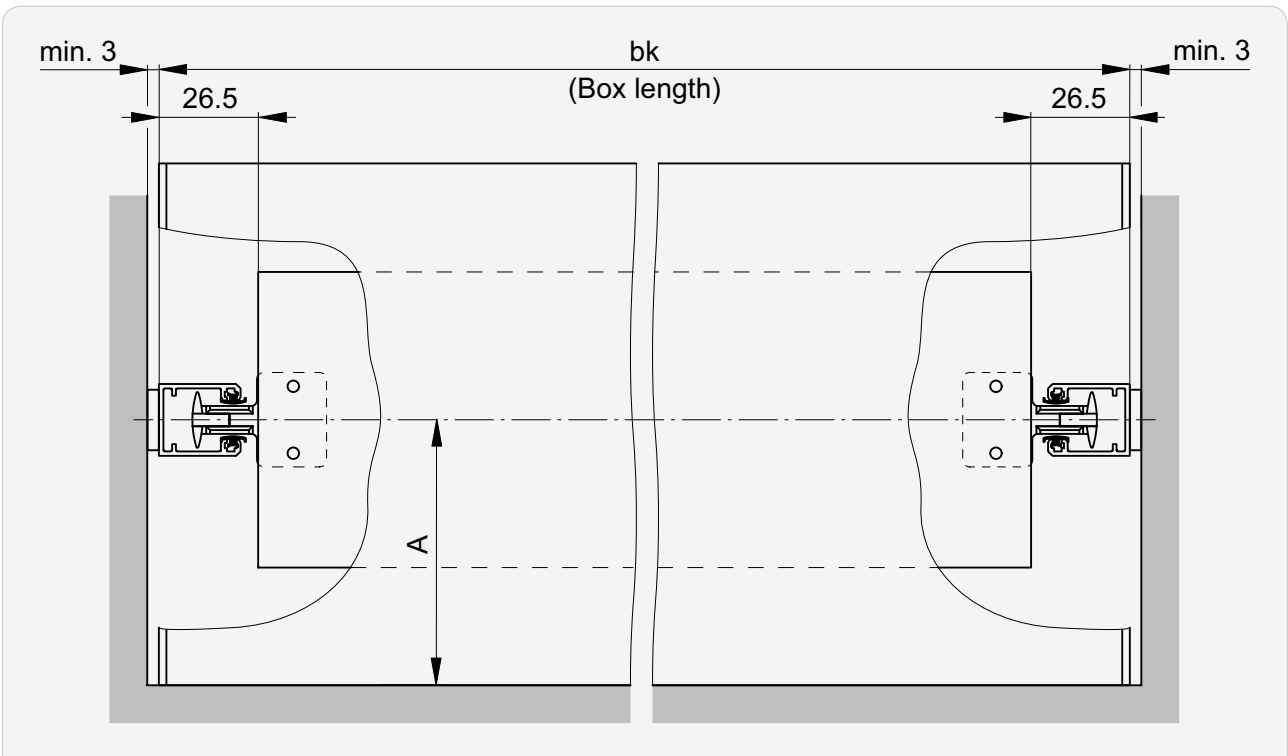

➡ Value for A 247

▶▶ Sections | Details

Detail at bottom

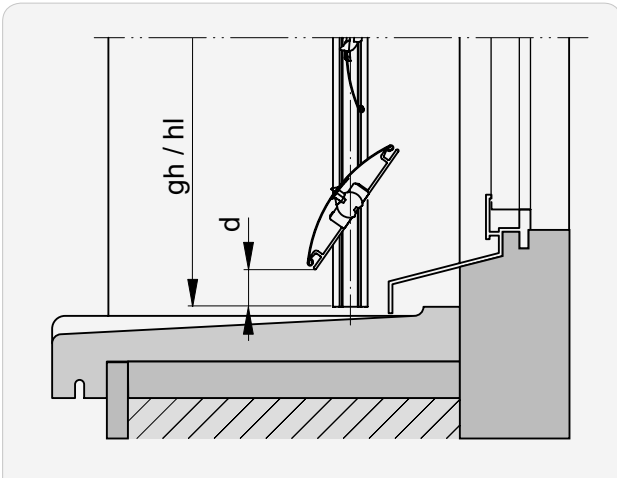
**d (d-dimension)**

min. 10 +5/-3

i **d-dimension** may vary with different blind dimensions.

Sections for crank drive (MBMA)

outside bk

Conventional

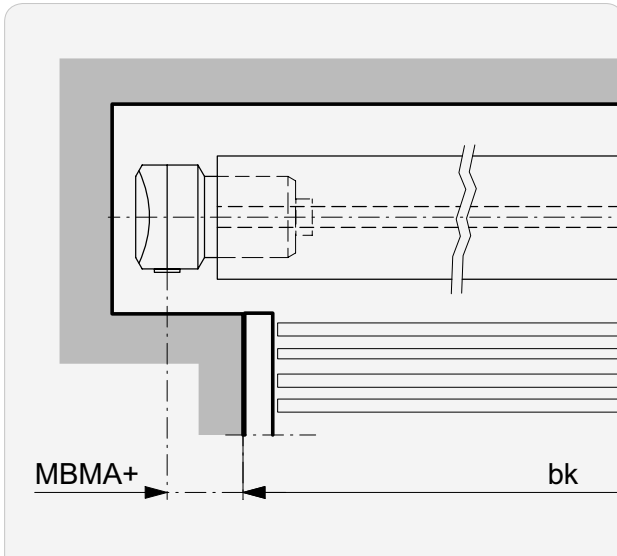

Self-supporting (Fix)

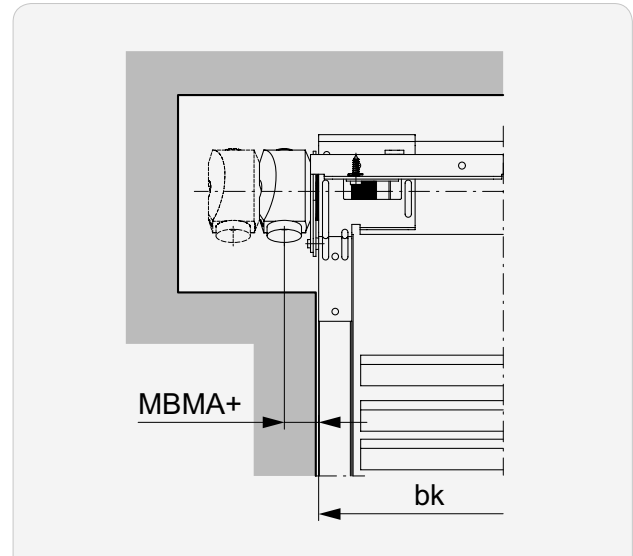

within bk

Conventional

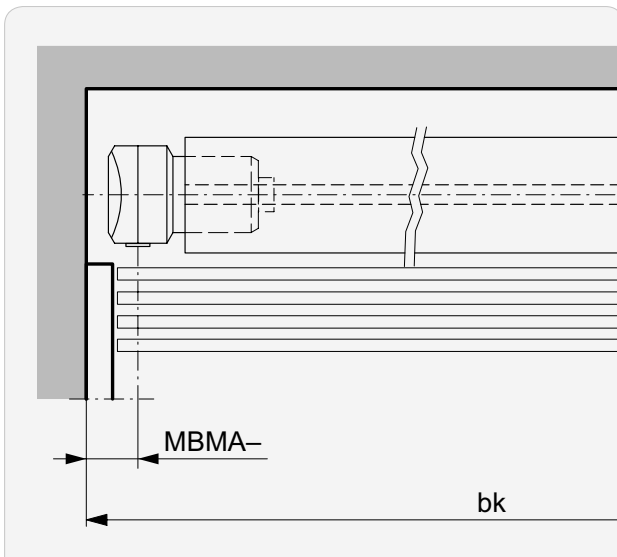

Self-supporting (Fix)

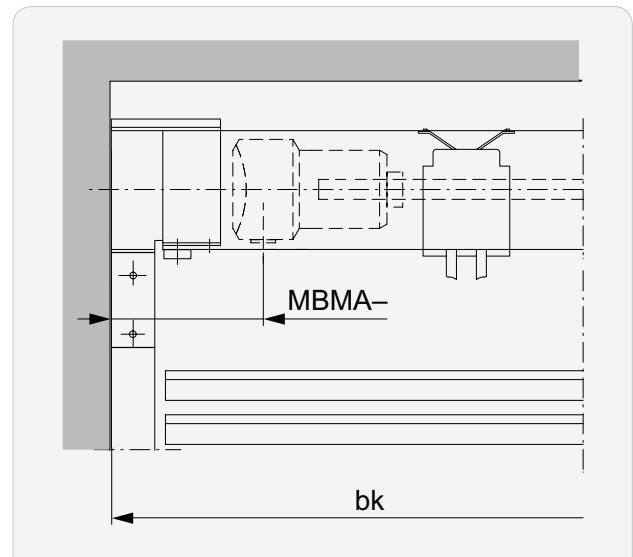

Version	MBMA+	MBMA-
Conventional	0 ... 999	0 ... (bk/2)*
Self-supporting (Fix)	26 ... 125 (10 ... 25) ¹	90 ... (bk/2)

¹ for reverse mounted gearbox

* ≤30: Gearbox niche required

Vertical connections | Standard motor position

Number of bearings

Solomatic® II 70

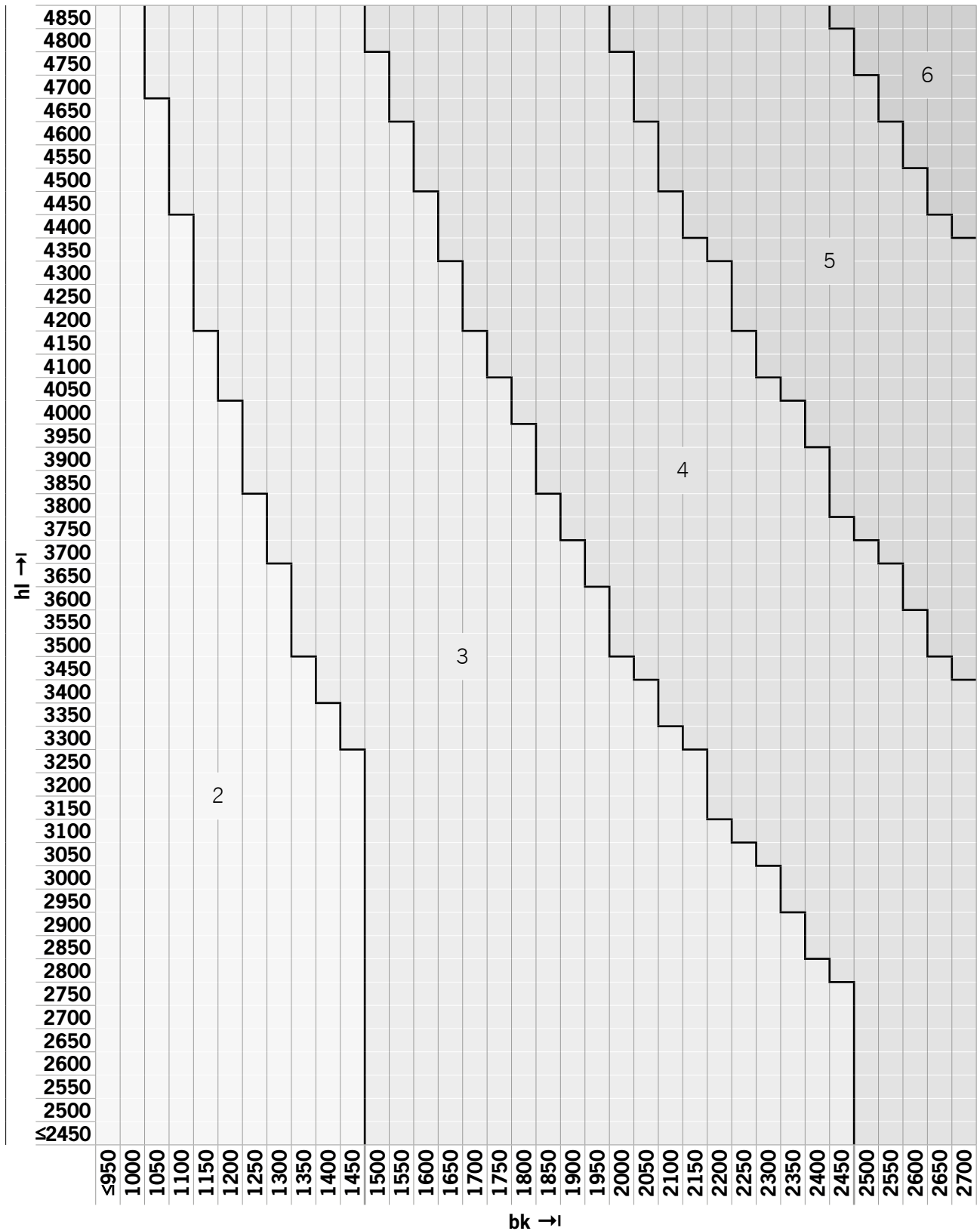

►► Vertical connections | Standard motor position

Number of bearings

Solomatic® II 70

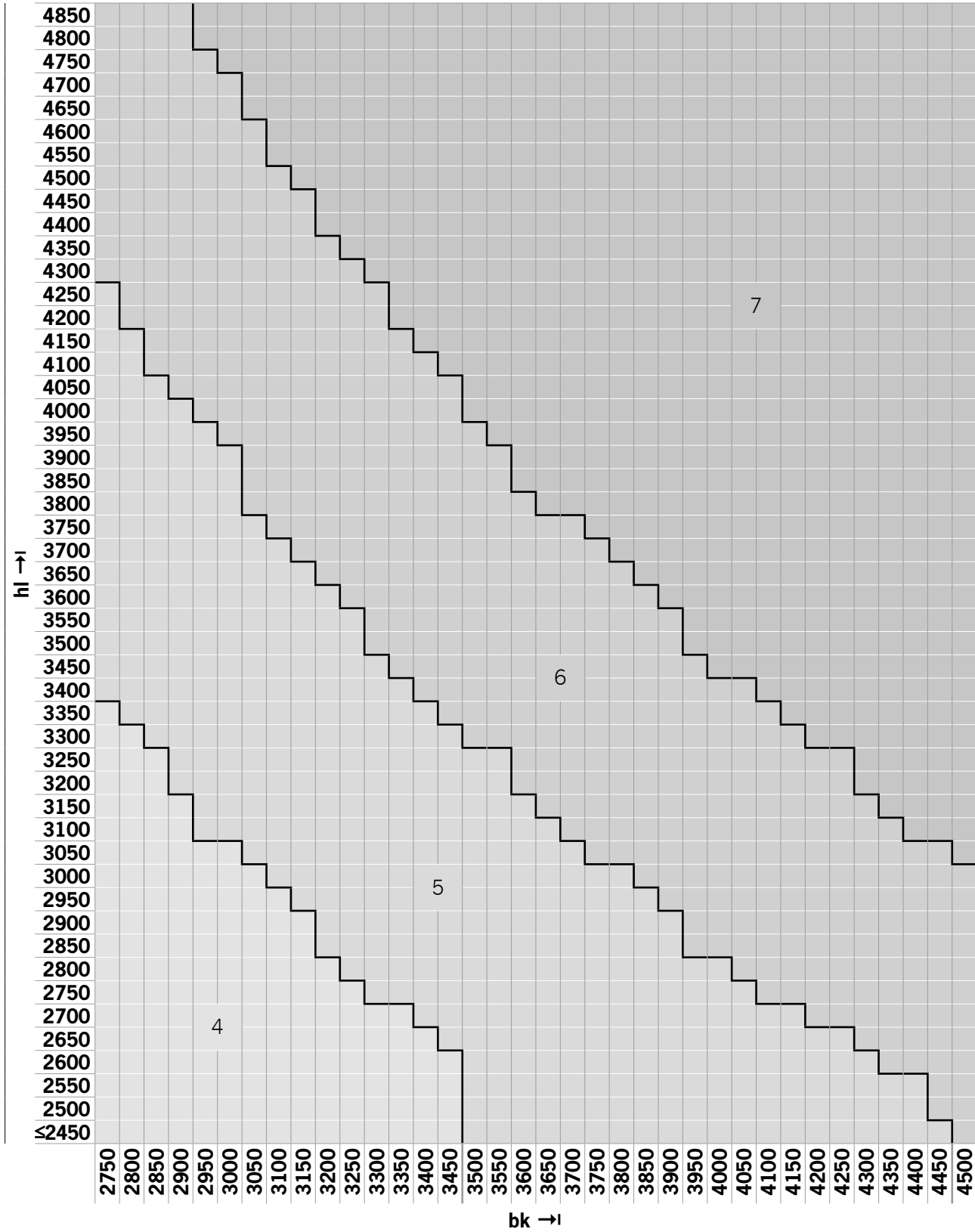

►► Vertical connections | Standard motor position

Number of bearings

Solomatic® II 80

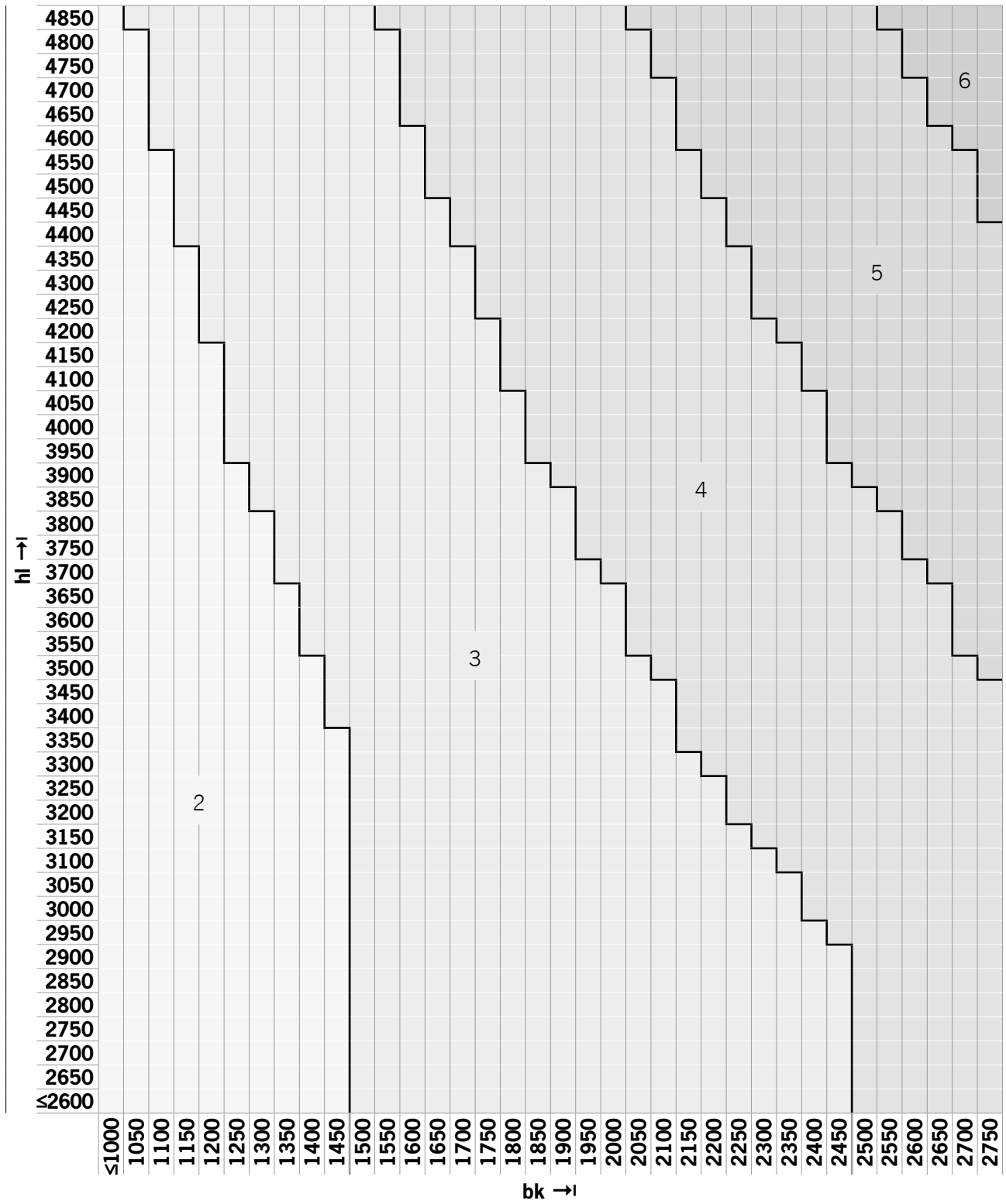

►► Vertical connections | Standard motor position





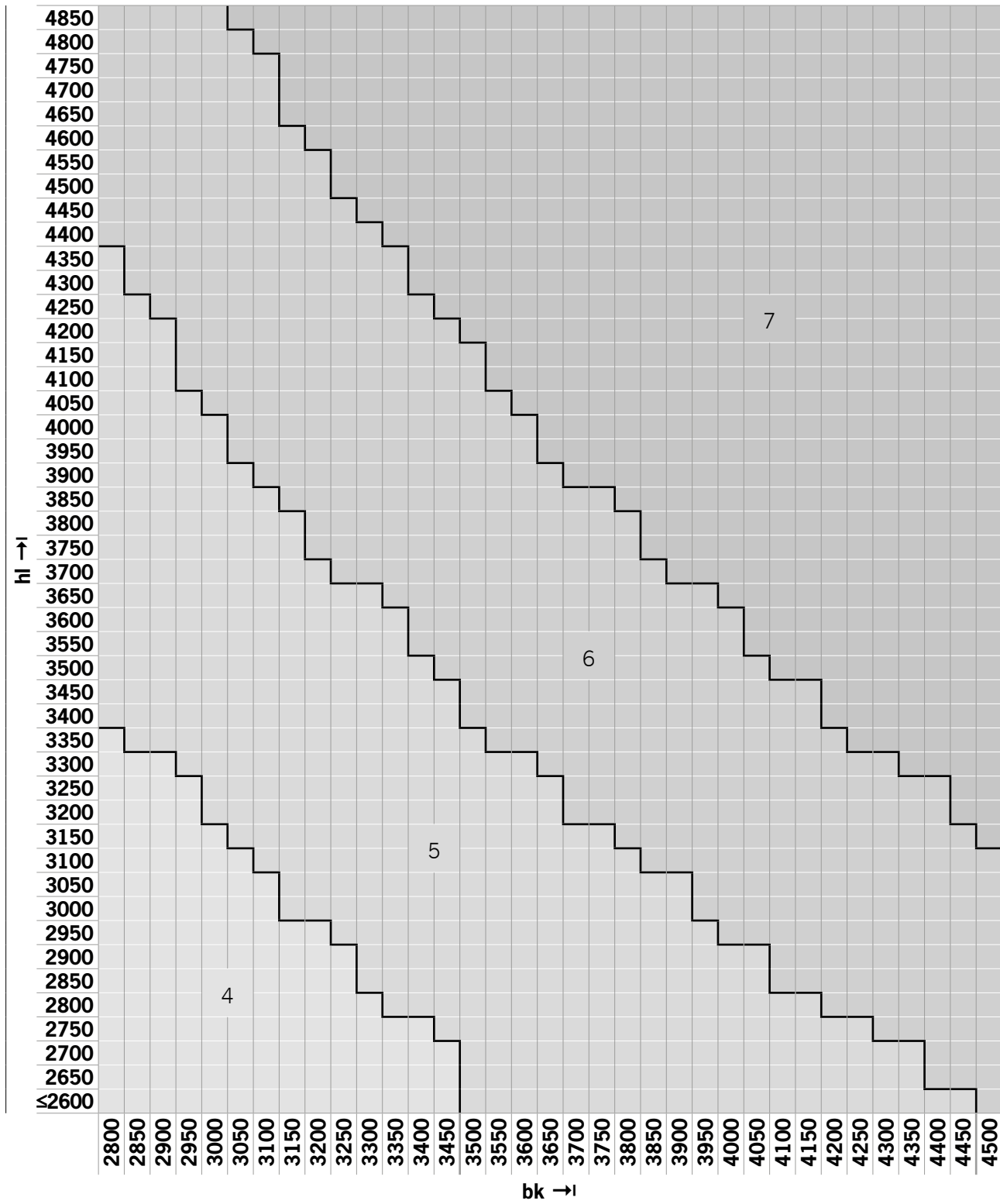

Number of bearings



Solomatic® II 80



►► Vertical connections | Standard motor position

Standard motor position

Number of bearings	Standard motor position
2	
3	
4	
5	
6	
7	

-  Bearing
-  Standard motor position
-  Possible motor position (on request)

Guide rail installation (principle)

Guides attached (to soffit) | Type A

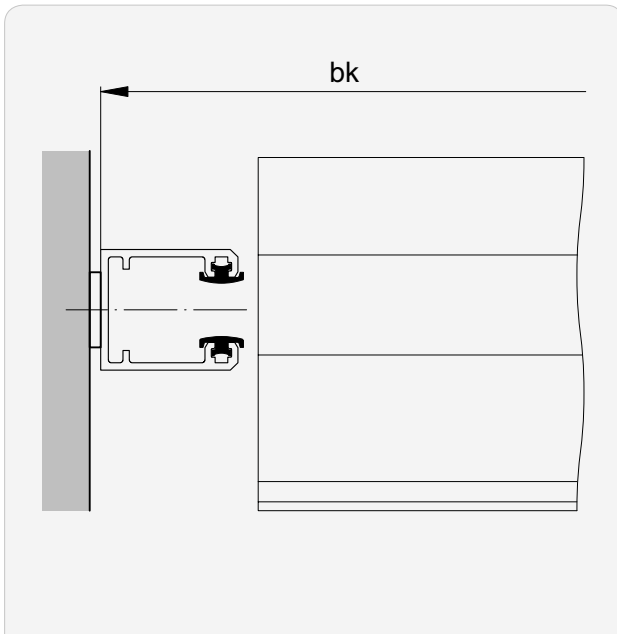

Guides suspended

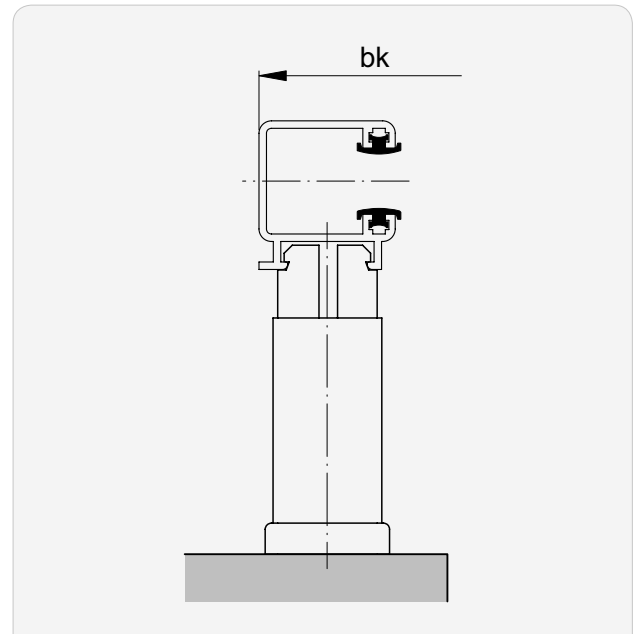

i Observe possible guide rail spacer for **bk**.
Standard: 2 mm

►► Guide rail installation (principle)

Guides recessed

i *Type F | Without guide cut-out:
Only possible if curtain can be retracted from below.

Type E | F* | L

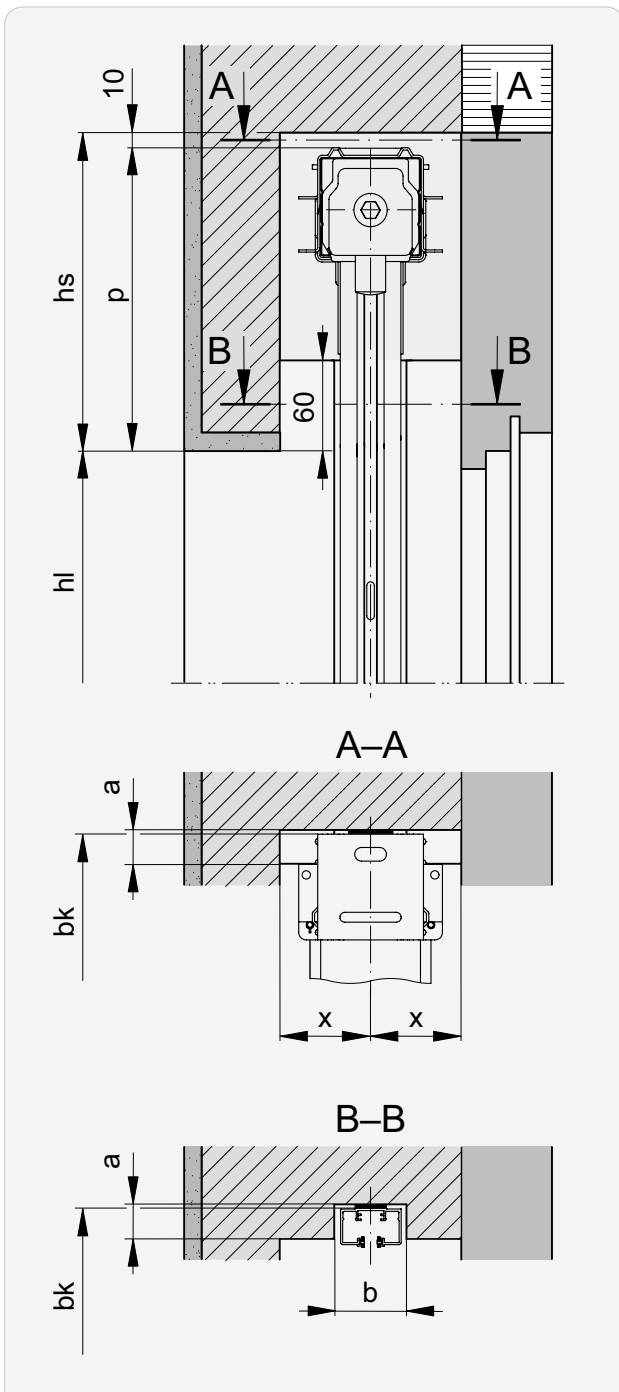

Type E

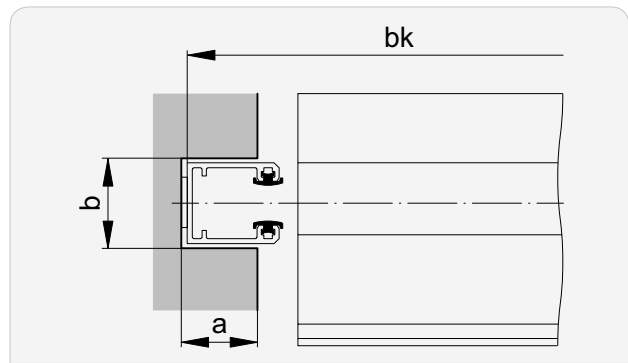

Type F*

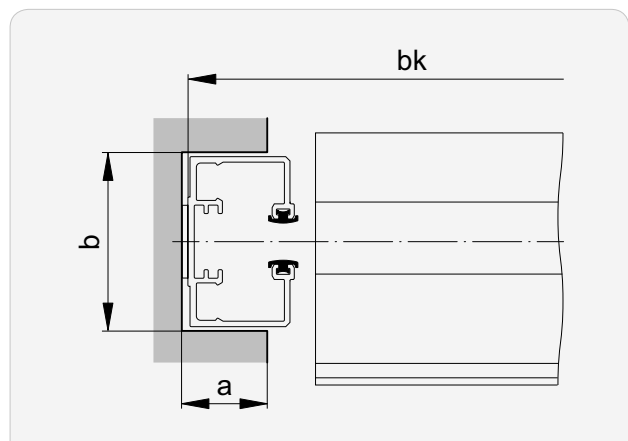

Type L

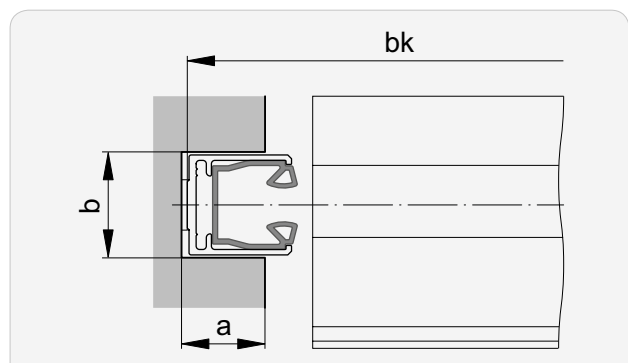

Product Version	x min.
Solomatic® II 70 Fix	50
Solomatic® II 80 Fix	60

Type	a	b
E	≤18	≥21
F*	≤20	≥42
L	≤24	≥25

Guide rail fastenings (principle)

Overview

														Type	
A	B	Bd	C	Cd	E	F	G	H	Kv	M	T	Tv	V	Wv	
●	●	●	●	●	●	●	–	○ ¹	○ ²	○ ³	●	●	●	●	

- applicable without restrictions
- applicable with restrictions:
 - ¹ only with guide **type D**
 - ² only with guide **type C | T | R**
 - ³ only with guide **type E**

A Soffit installation

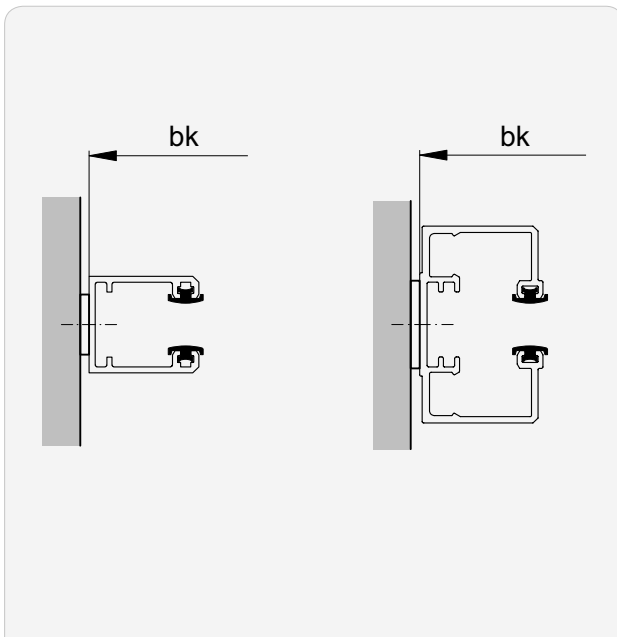

i Observe possible guide rail spacer for **bk**.
Standard: 2 mm

►► Guide rail fastenings (principle)

B Installation with fastening bracket

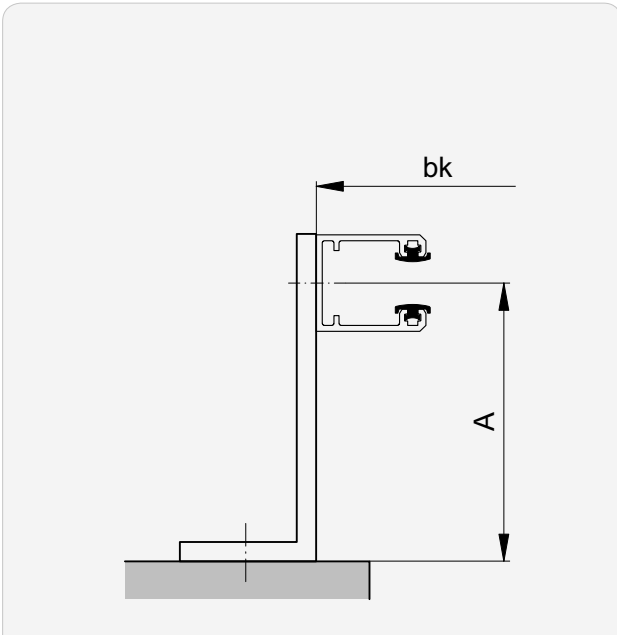

Bracket outwards

C Installation with fastening bracket

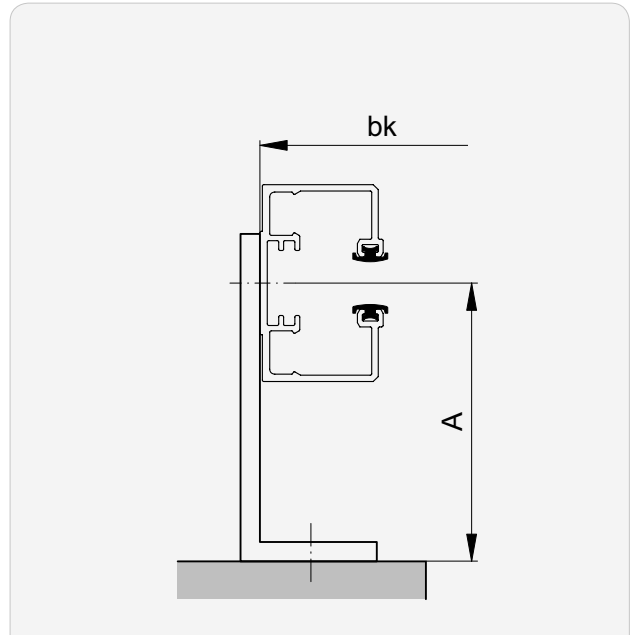

Bracket inwards

Fastening bracket for types B and C

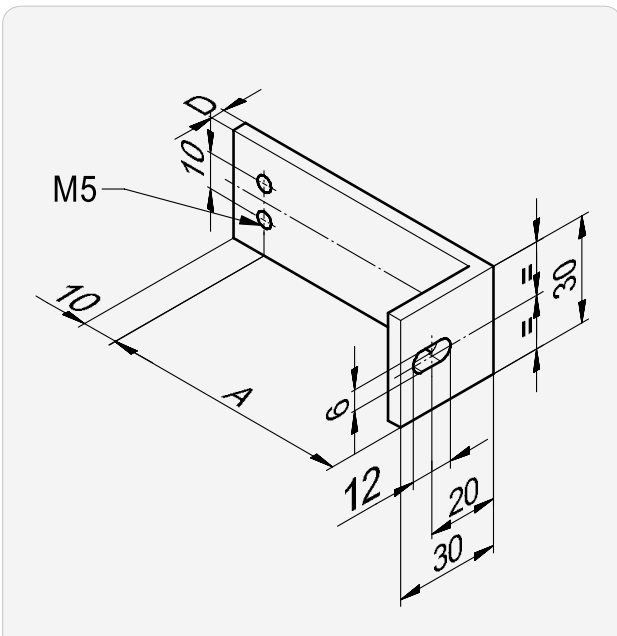

A*	D
20... 115	4

Fastening bracket 70 mm for types B and C

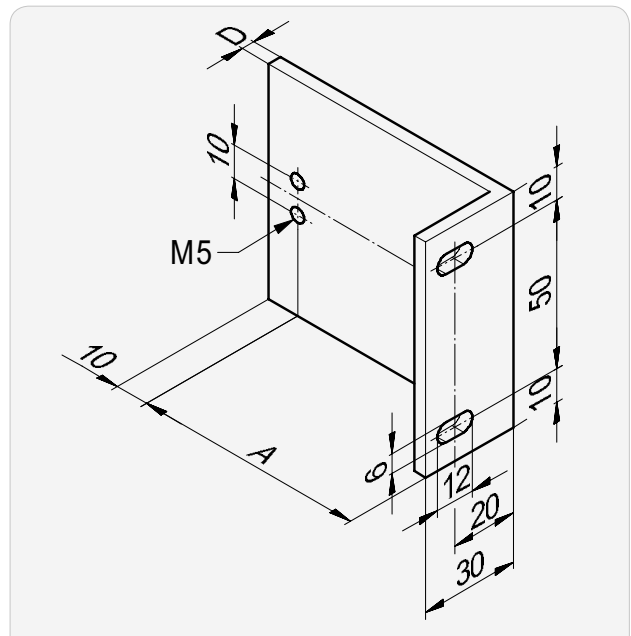

A*	D
20... 115	4
120... 215	5

i For suspended guide rails always with **brackets 70mm**.

i If the **projection is ≥120**, all products are fastened with a **70mm bracket**.

* in 5 mm steps

►► Guide rail fastenings (principle)

Bd Installation with continuous fastening bracket

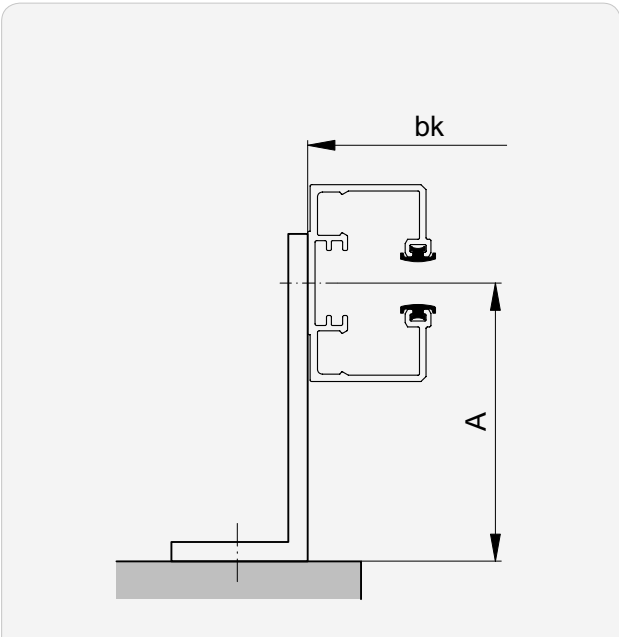

Bracket outwards

Cd Installation with continuous fastening bracket

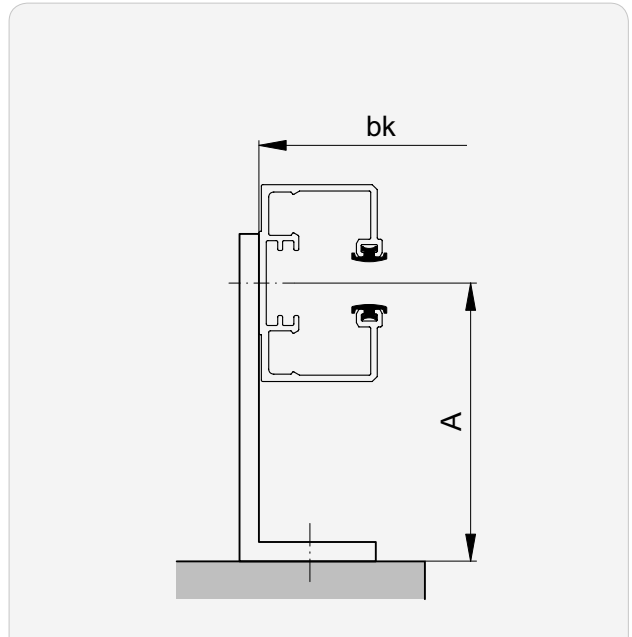

Bracket inwards

Continuous fastening bracket for types Bd and Cd

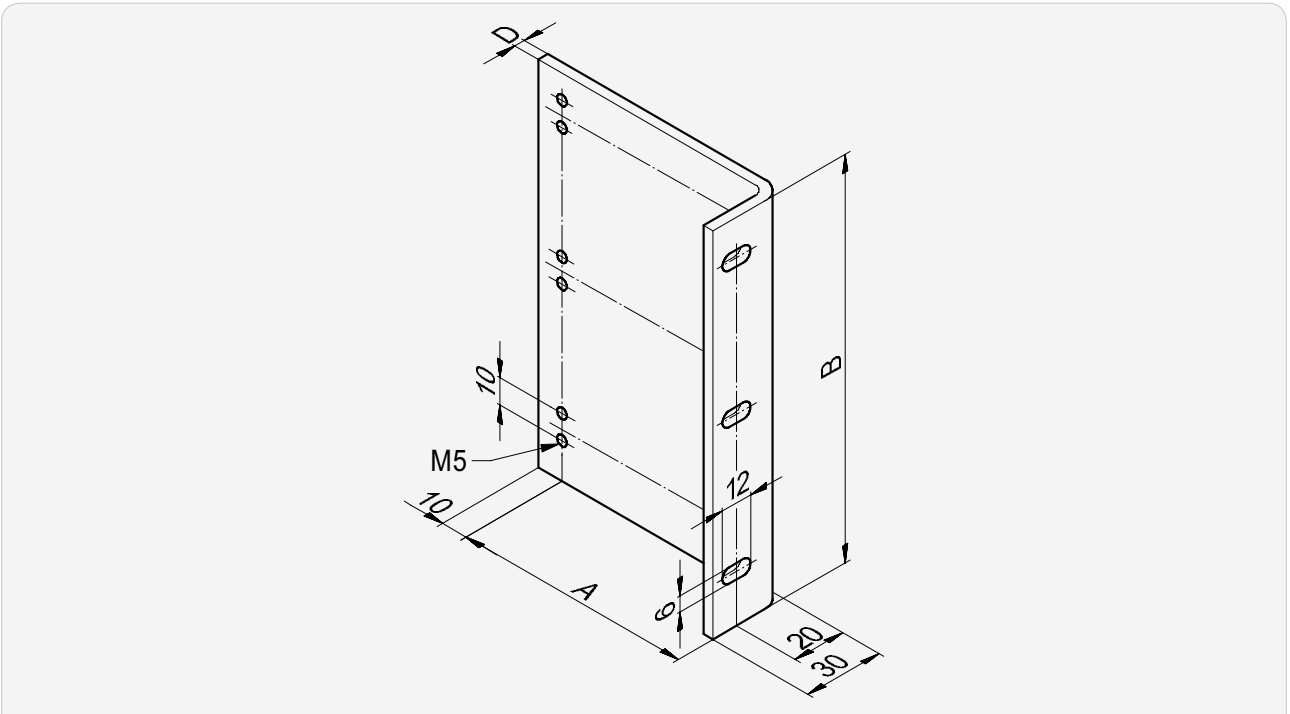

A*	D
20...300	always 4

* in 5 mm steps

►► Guide rail fastenings (principle)

E|F Installation with fastening lug

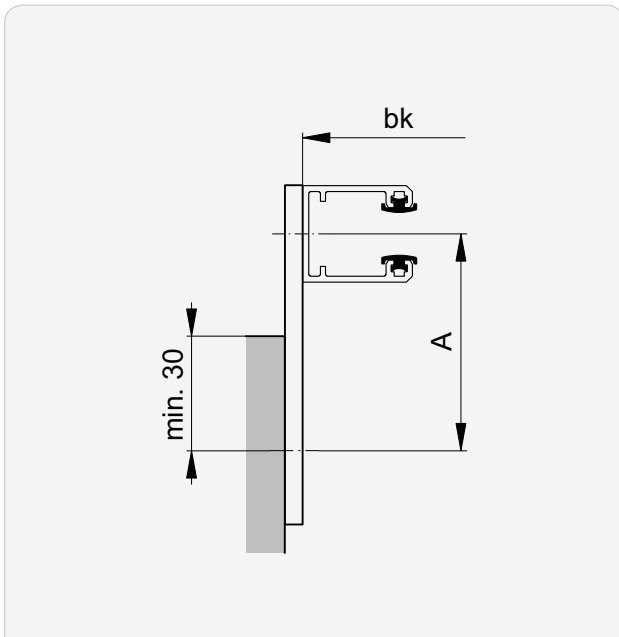

inwards / outwards

H Installation with spacer

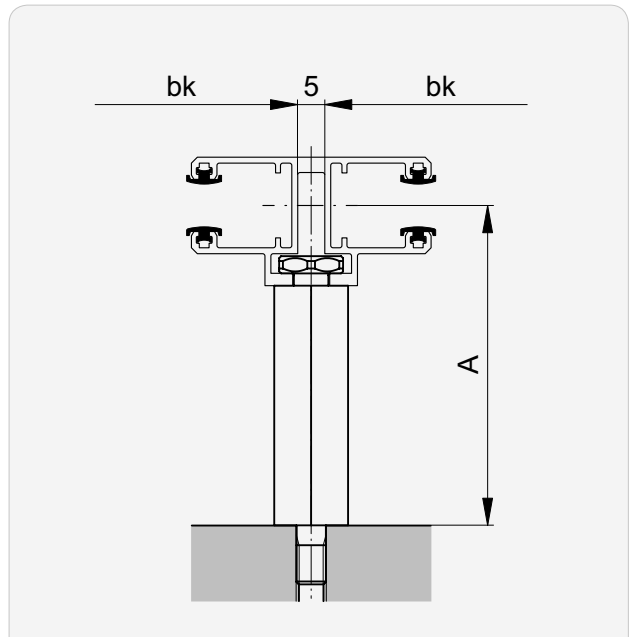

Only with guide type D

Fastening lug for type E | F

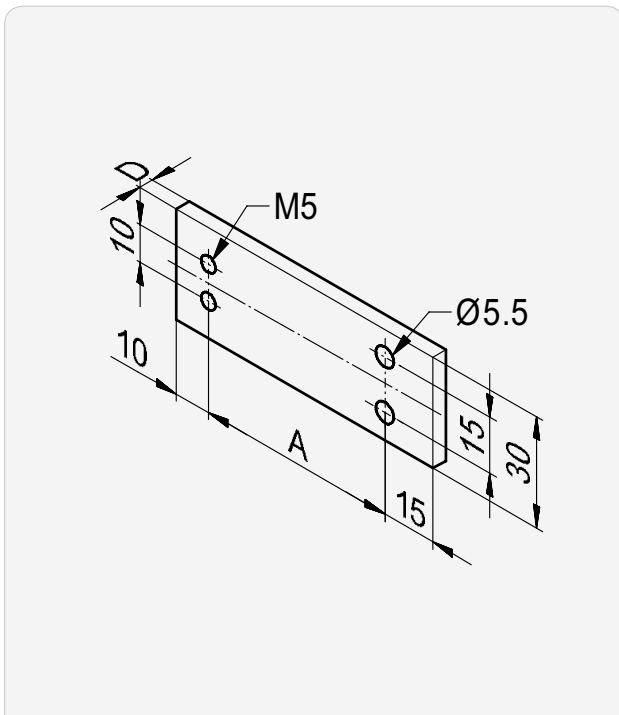

A*	D
50... 115	4
120... 125	5

* in 5 mm steps

Spacer for type H

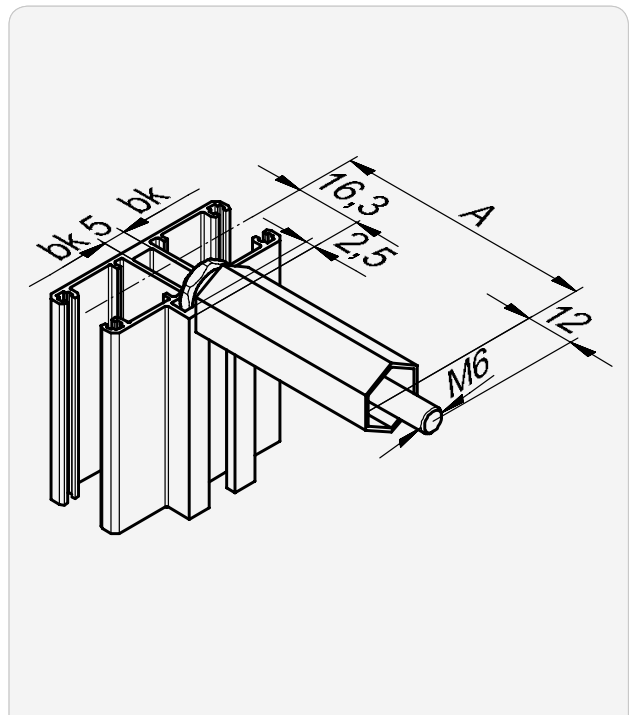

A
35... 115

►► Guide rail fastenings (principle)

Kv Installation with adjustable console

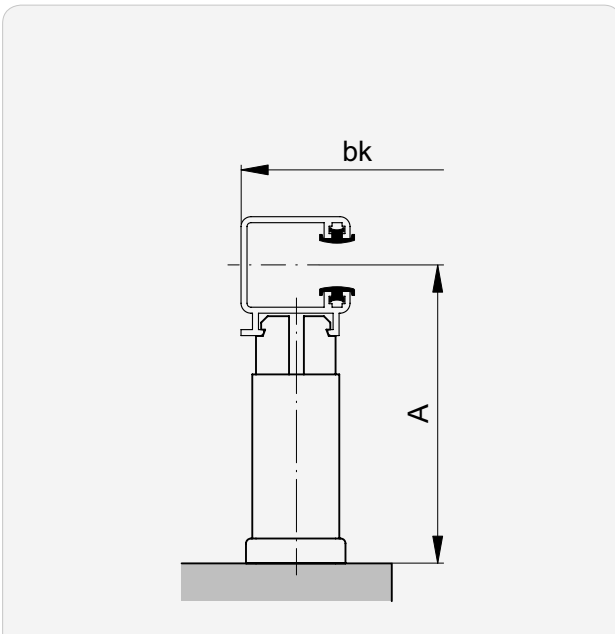

Only with guide type C | T | R

Console for type Kv

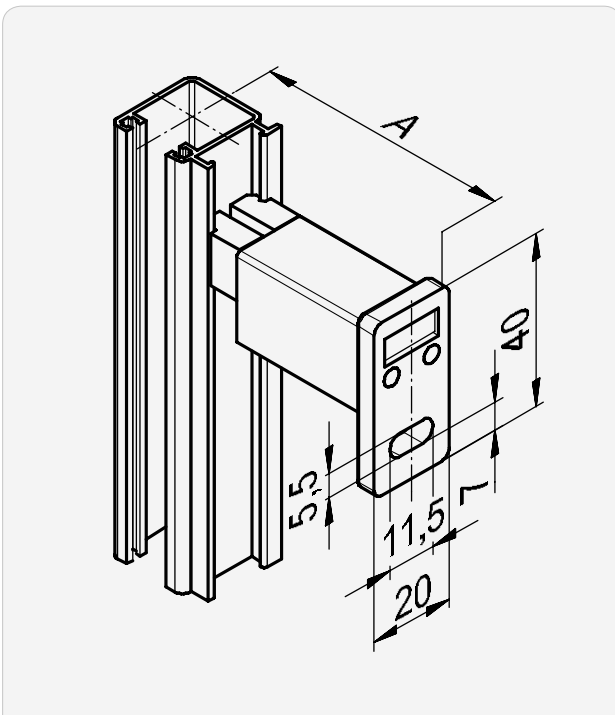

A	A
60... 75	121... 135
76... 90	136... 150
91... 105	151... 165
106... 120	166... 180
	181... 195

►► Guide rail fastenings (principle)

M Installation with centre bracket

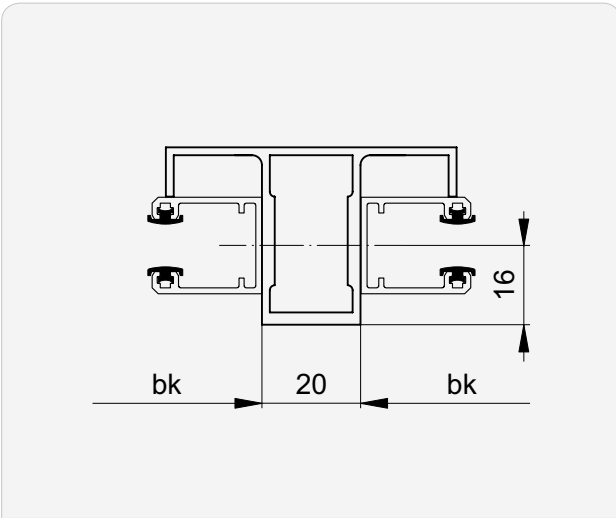

i Only with guide type E
Length = Guide length

Principle

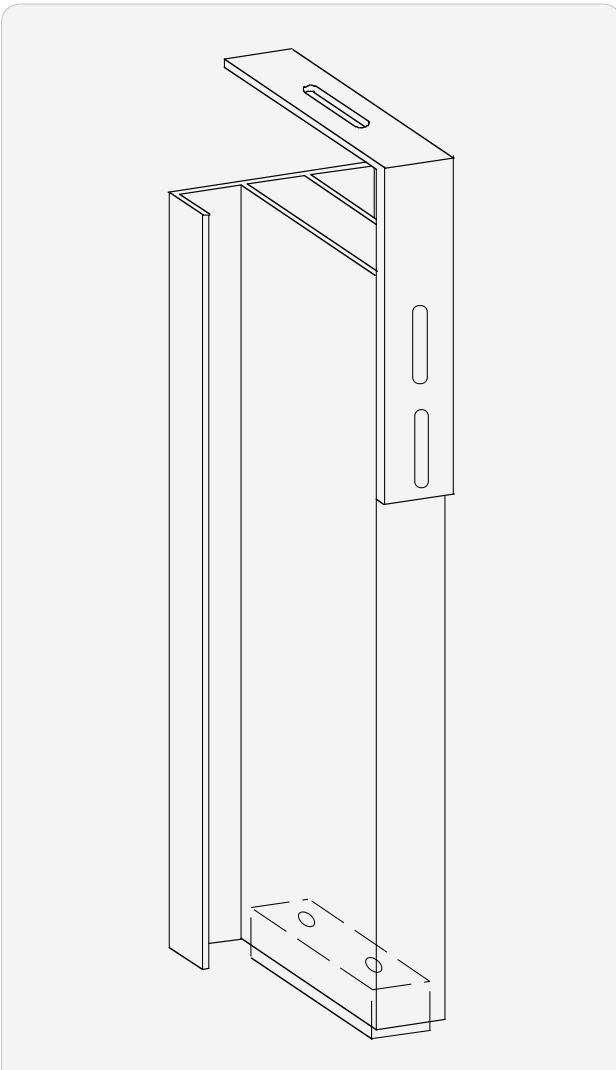

Fastening bracket above centre bracket

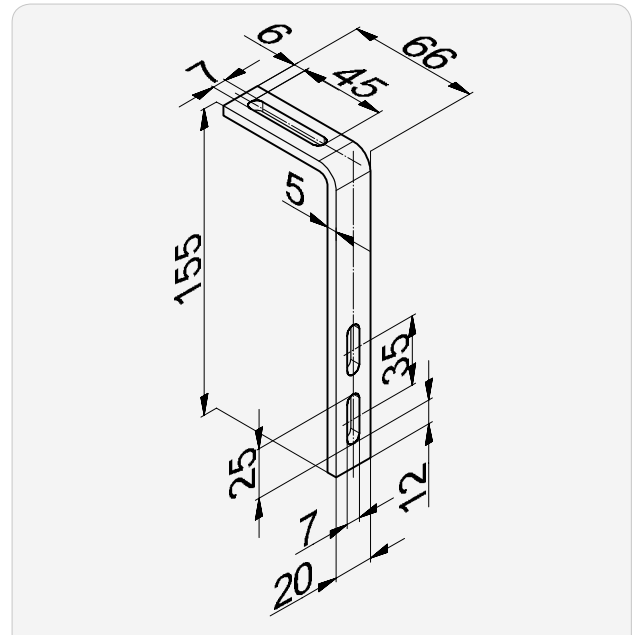

Fastening square below for centre bracket

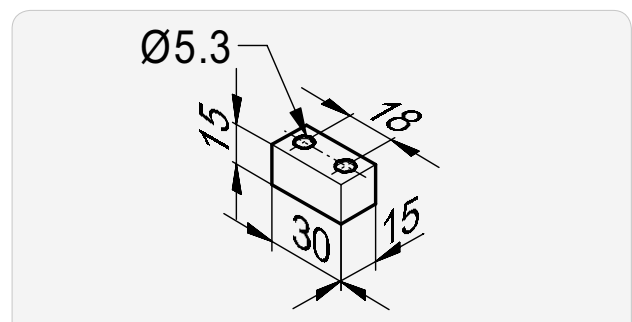

►► Guide rail fastenings (principle)

T Installation with T-bracket

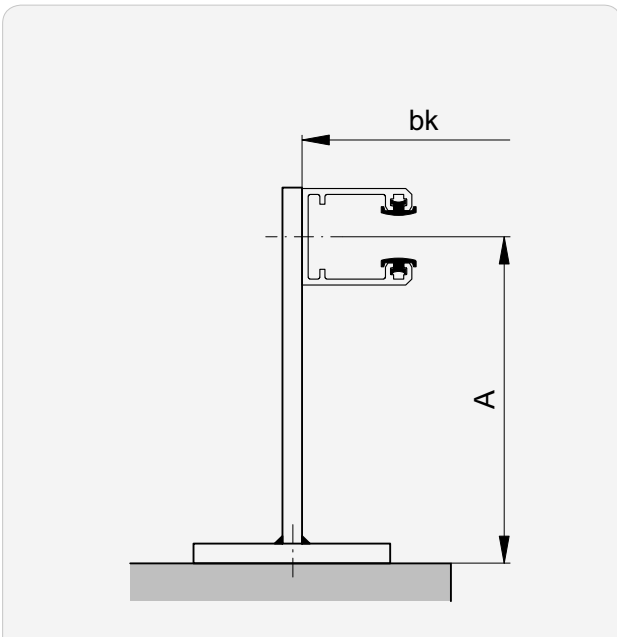

Tv Installation with adjustable T-bracket

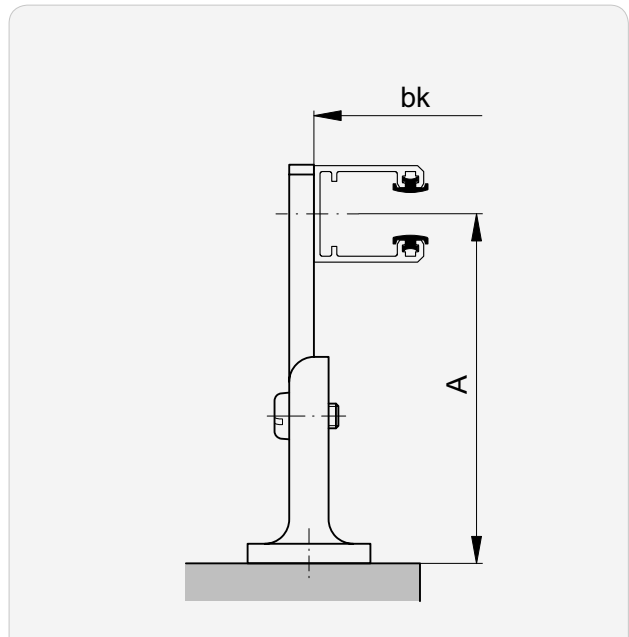

T-bracket for type T

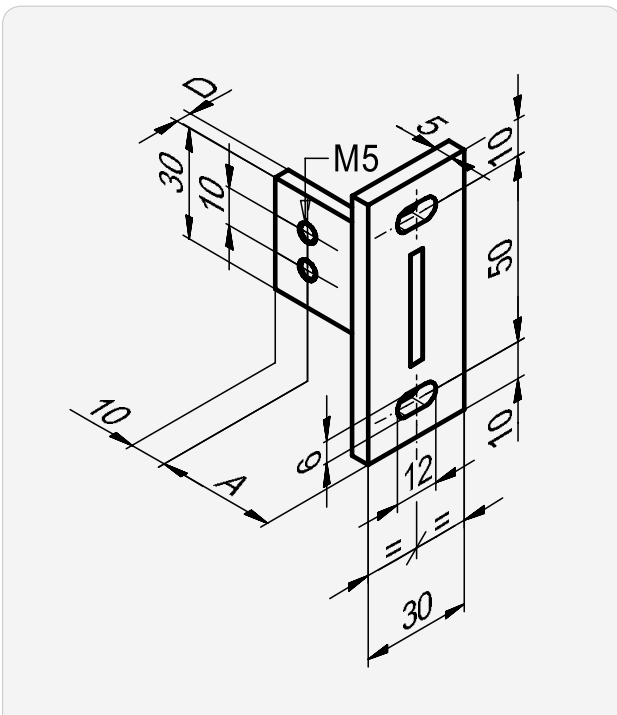

A	D
20... 115*	4
120... 215*	5

* in 5 mm steps

T-bracket adjustable for type Tv

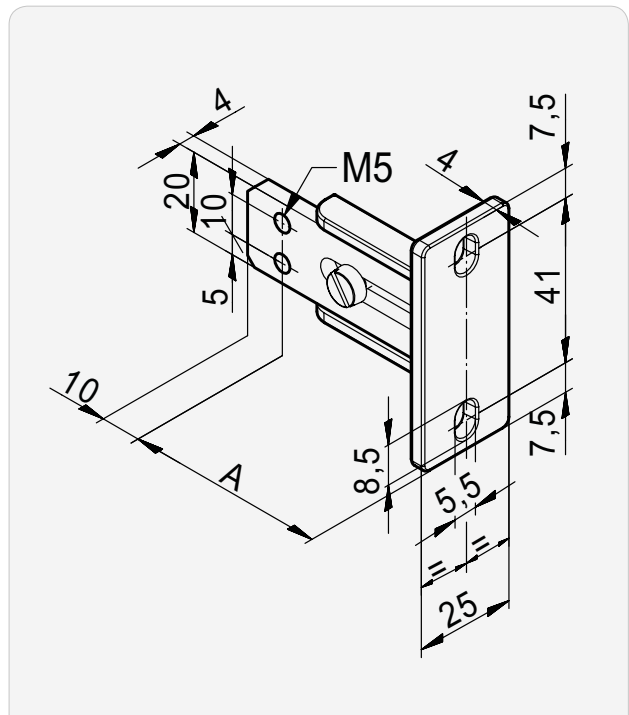

A
50... 68
69... 87
88... 106
107... 115

►► Guide rail fastenings (principle)

T Installation with one bracket

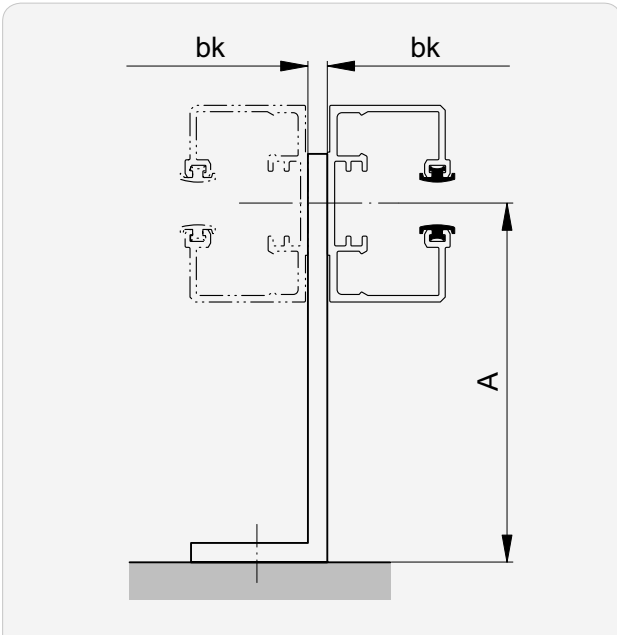

The blind on the right uses the fastening for the blind on the left.

Wv Installation with adjustable bracket

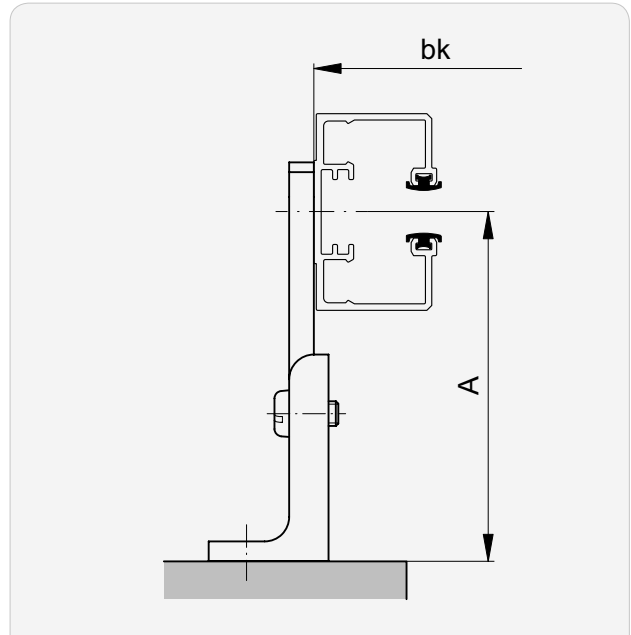

W-bracket adjustable for type Wv

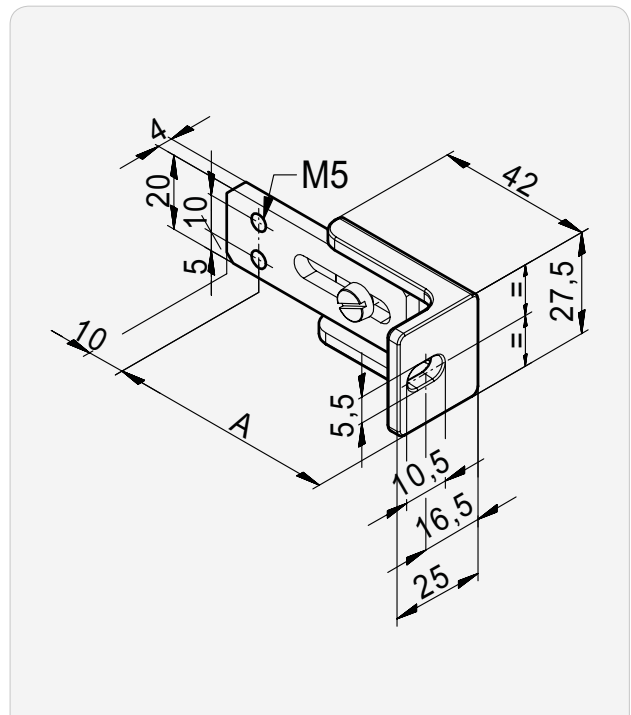

A

50...68

69...87

88...106

107...115

Guide extension and facet

Extension

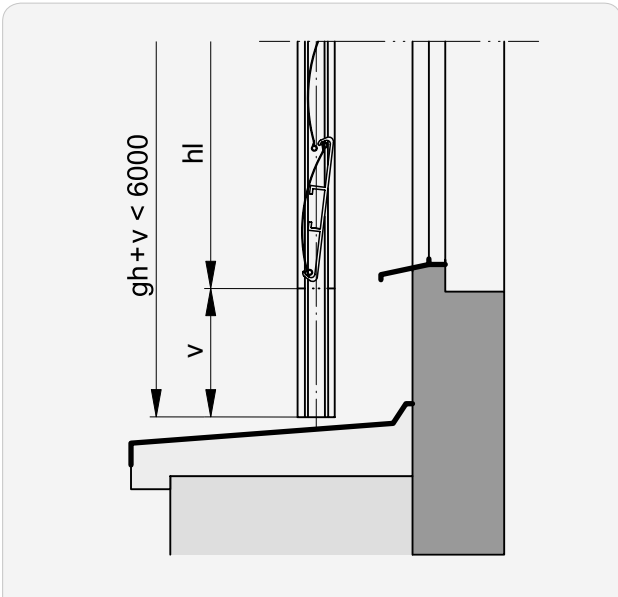

v
-20... 3000

Facet

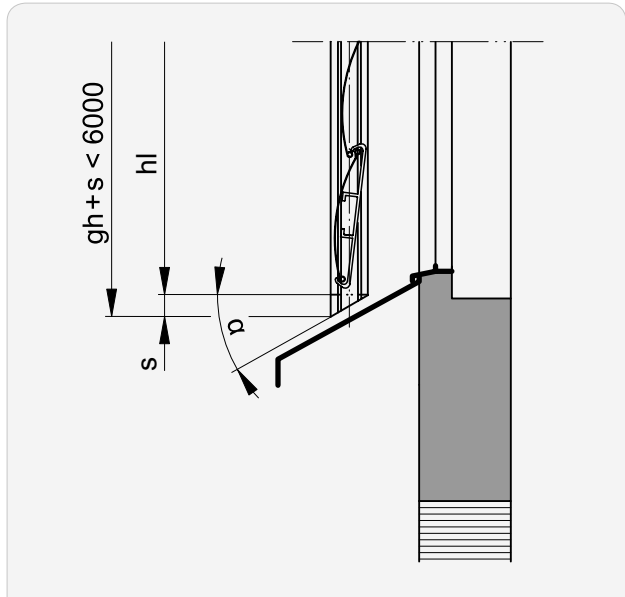

α
5... 50°

Extension and facet

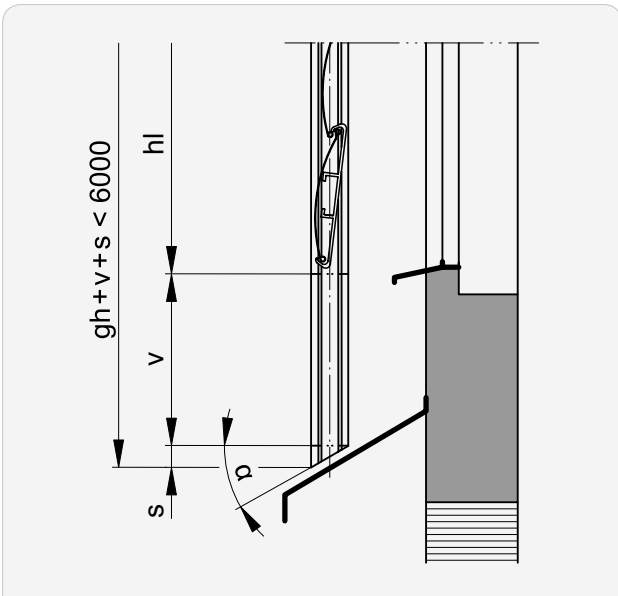

v
0... 3000

α
5... 50°

➔ Value for **s**.....277

Angling at the guides

Type E | Single guide

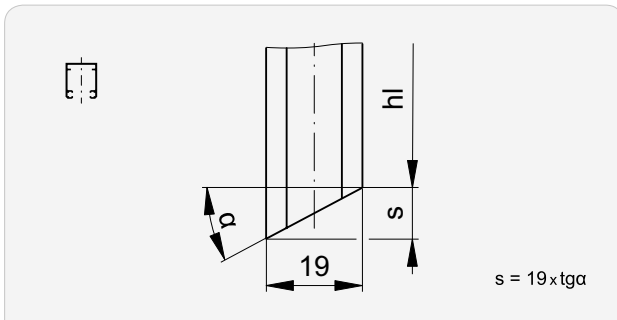

α	s	α	s	α	s	α	s	α	s
5	2	15	5	25	9	35	13	45	19
6	2	16	5	26	9	36	14	46	20
7	2	17	6	27	10	37	14	47	20
8	3	18	6	28	10	38	15	48	21
9	3	19	7	29	11	39	15	49	22
10	3	20	7	30	11	40	16	50	23
11	4	21	7	31	11	41	17		
12	4	22	8	32	12	42	17		
13	4	23	8	33	12	43	18		
14	5	24	8	34	13	44	18		

Type C | Single guide

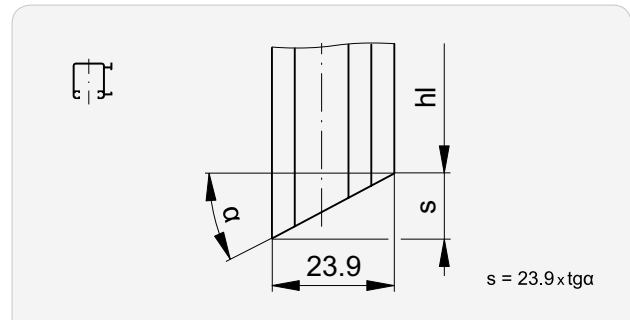

α	s	α	s	α	s	α	s	α	s
5	2	15	6	25	11	35	17	45	24
6	3	16	7	26	12	36	17	46	25
7	3	17	7	27	12	37	18	47	26
8	3	18	8	28	13	38	19	48	27
9	4	19	8	29	13	39	19	49	27
10	4	20	9	30	14	40	20	50	28
11	5	21	9	31	14	41	21		
12	5	22	10	32	15	42	22		
13	6	23	10	33	16	43	22		
14	6	24	11	34	16	44	23		

Type L | Fix guide

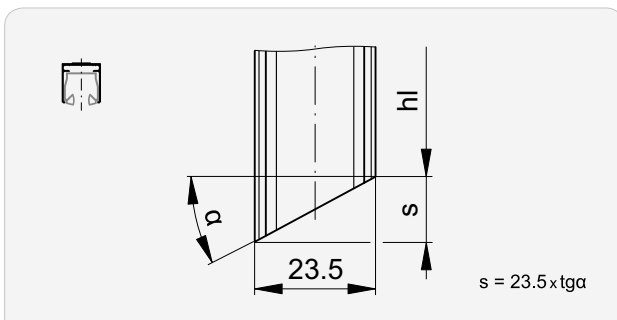

α	s	α	s	α	s	α	s	α	s
5	2	15	6	25	11	35	16	45	24
6	2	16	7	26	11	36	17	46	24
7	3	17	7	27	12	37	18	47	25
8	3	18	8	28	12	38	18	48	26
9	4	19	8	29	13	39	19	49	27
10	4	20	9	30	14	40	20	50	28
11	5	21	9	31	14	41	20		
12	5	22	9	32	15	42	21		
13	5	23	10	33	15	43	22		
14	6	24	10	34	16	44	23		

Type F | Fix guide

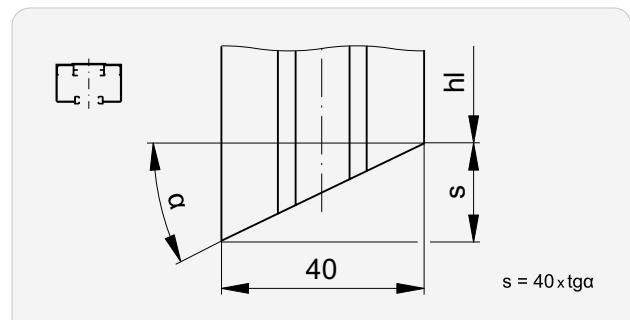

α	s	α	s	α	s	α	s	α	s
5	3	15	11	25	19	35	28	45	40
6	4	16	11	26	20	36	29	46	41
7	5	17	12	27	20	37	30	47	43
8	6	18	13	28	21	38	31	48	44
9	6	19	14	29	22	39	32	49	46
10	7	20	15	30	23	40	34	50	48
11	8	21	15	31	24	41	35		
12	9	22	16	32	25	42	36		
13	9	23	17	33	26	43	37		
14	10	24	18	34	27	44	39		

►► Angling at the guides

Type T | Double guide

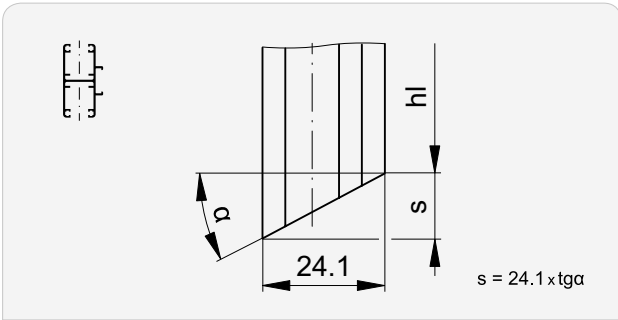

α	s	α	s	α	s	α	s	α	s
5	2	15	6	25	11	35	17	45	24
6	3	16	7	26	12	36	18	46	25
7	3	17	7	27	12	37	18	47	26
8	3	18	8	28	13	38	19	48	27
9	4	19	8	29	13	39	20	49	28
10	4	20	9	30	14	40	20	50	29
11	5	21	9	31	14	41	21		
12	5	22	10	32	15	42	22		
13	6	23	10	33	16	43	22		
14	6	24	11	34	16	44	23		

Type D | Double guide

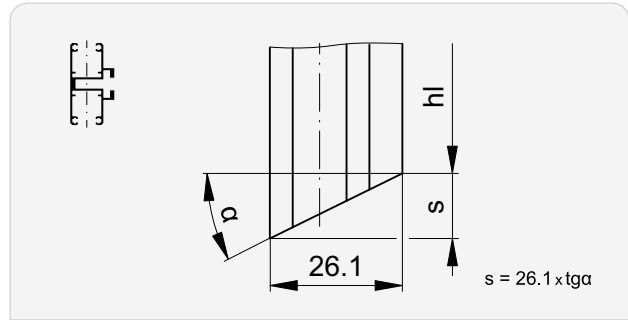

α	s	α	s	α	s	α	s	α	s
5	2	15	7	25	12	35	18	45	26
6	3	16	7	26	13	36	19	46	27
7	3	17	8	27	13	37	20	47	28
8	4	18	8	28	14	38	20	48	29
9	4	19	9	29	14	39	21	49	30
10	5	20	9	30	15	40	22	50	31
11	5	21	10	31	16	41	23		
12	6	22	11	32	16	42	24		
13	6	23	11	33	17	43	24		
14	7	24	12	34	18	44	25		

Type R | Curved double guide

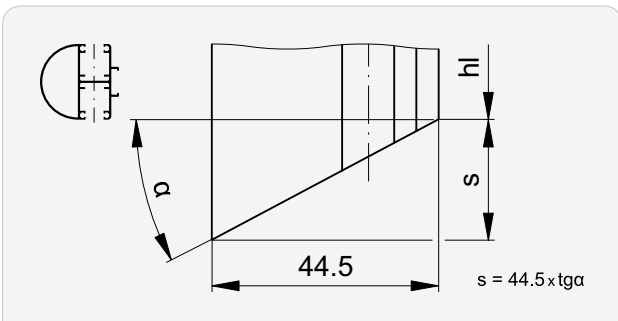

α	s	α	s	α	s	α	s	α	s
5	4	15	12	25	21	35	31	45	45
6	5	16	13	26	22	36	32	46	46
7	5	17	14	27	23	37	34	47	48
8	6	18	14	28	24	38	35	48	50
9	7	19	15	29	25	39	36	49	51
10	8	20	16	30	26	40	37	50	53
11	9	21	17	31	27	41	39		
12	9	22	18	32	28	42	40		
13	10	23	19	33	29	43	42		
14	11	24	20	34	30	44	43		

Guide rail cut-outs in windowsill area

Guide type						
C	D	E	F	L	R	T
-	-	●	●	●	-	-

Rear cut-out | without/with extension

Without extension

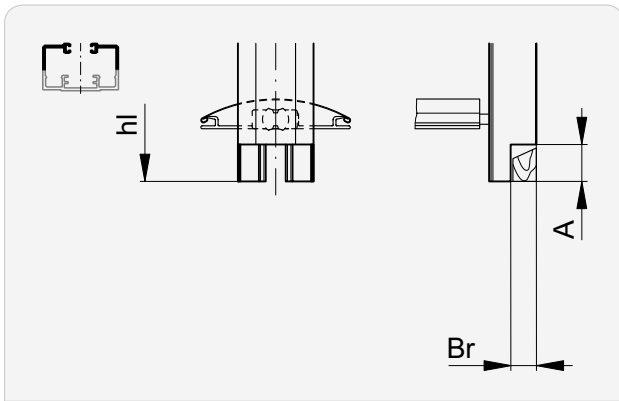

A	Guide type	Br		
		E	F	L*
0...25		2...3	2...4	2...4
		5...12	9...12	6

* FL ≥ 630

Extension | v ≤ A

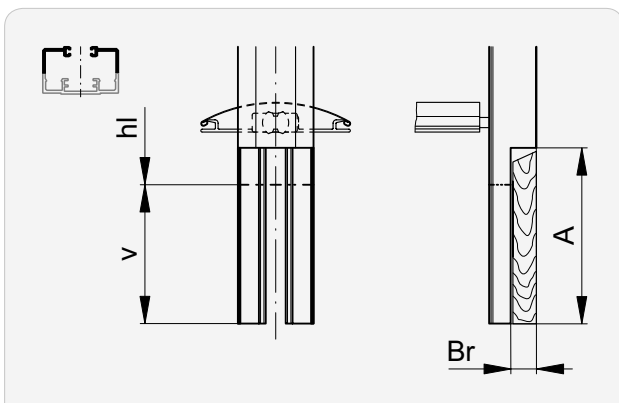

A	Guide type	Br		
		E	F	L*
0...25		2...3	2...4	2...4
		5...12	9...12	6

* FL ≥ 630

Extension | v > A

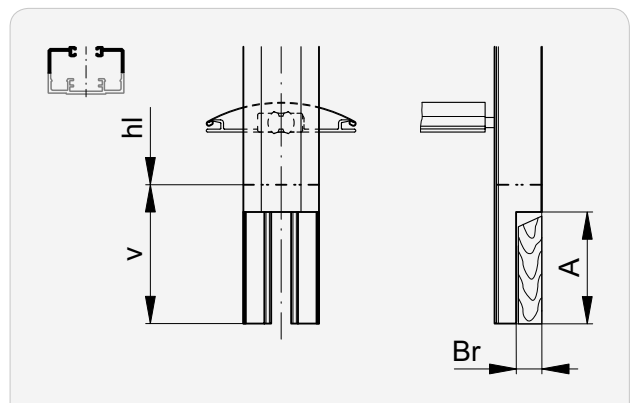

A	Guide type	Br		
		E	F	L*
0...25		2...3	2...4	2...4
		5...12	9...12	6

* FL ≥ 630

v Guide rail extension: 0...3000

►► Guide rail cut-outs in windowsill area

Inner cut-out | without/with extension

Without extension

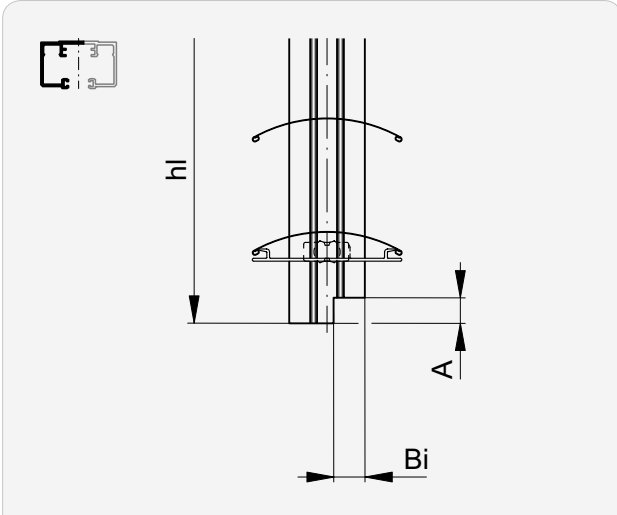

A	Guide type	Bi		L*
		E	F	
0...25		6...12	3...10	8...12

* FL ≥ 630

Extension | $v \leq A$

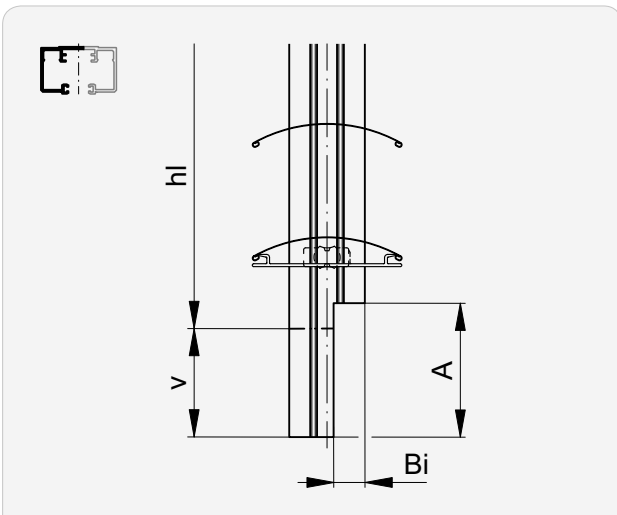

A	Guide type	Bi		L*
		E	F	
0...25		6...12	3...10	8...12

* FL ≥ 630

Extension | $v > A$

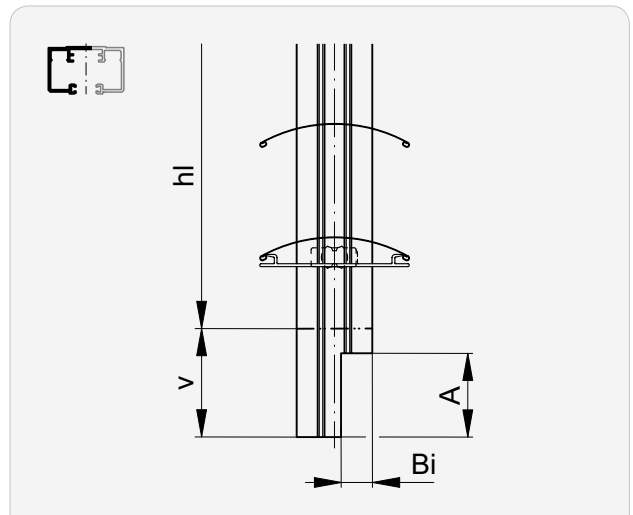

A	Guide type	Bi		L*
		E	F	
0...25		6...12	3...10	8...12

* FL ≥ 630

v Guide rail extension: 0...3000

Guide rail end for suspended guide rails

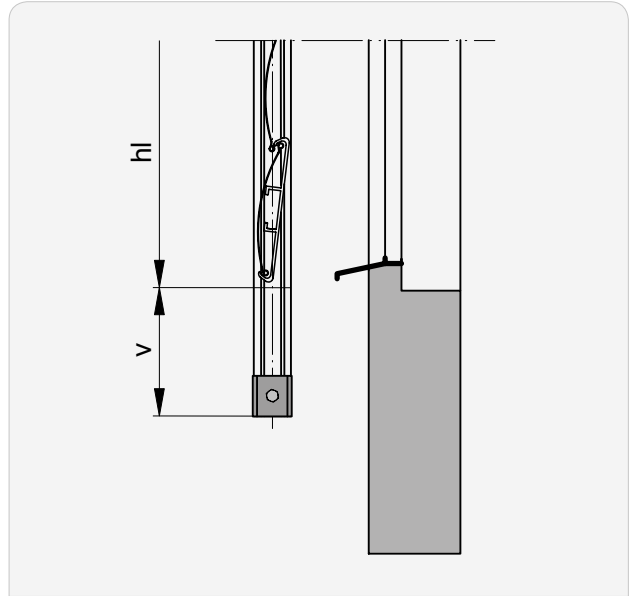
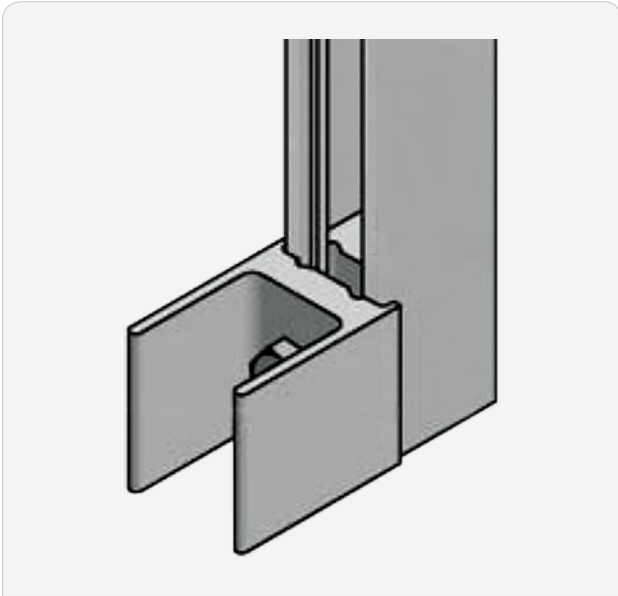

Guide type						
C	D	E	F	L	R	T
●	●	●	●	●	●	●

L*	v
70	≥30

* Guide fastening with local brackets.

Installation window

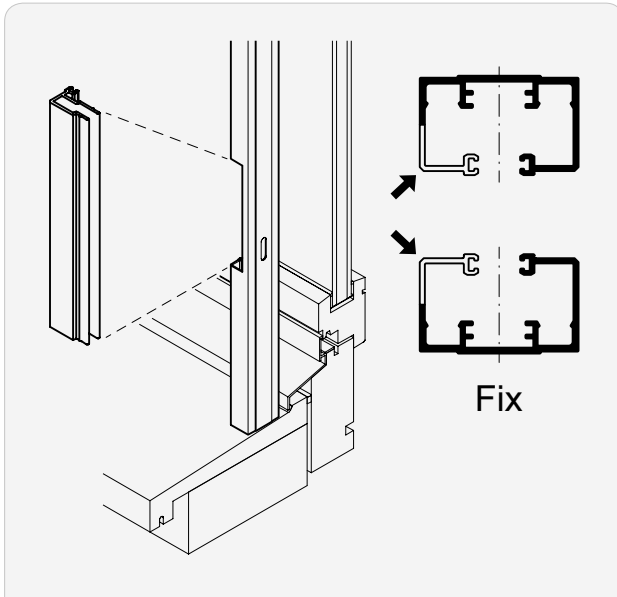

Without extension

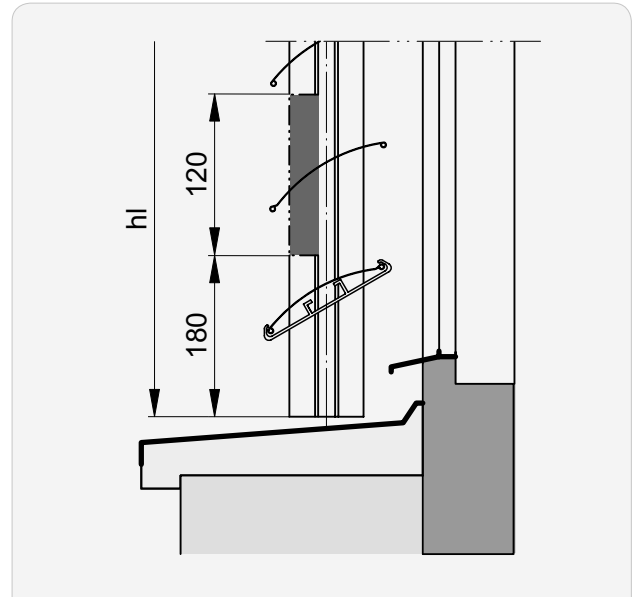

With extension

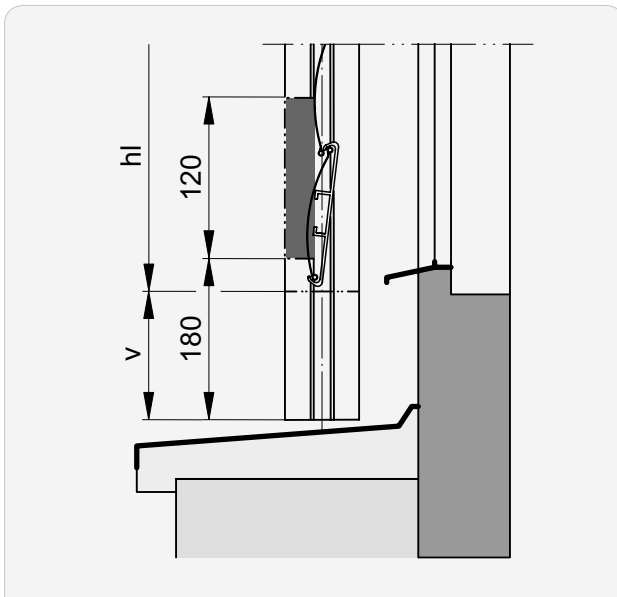

With extension and facet

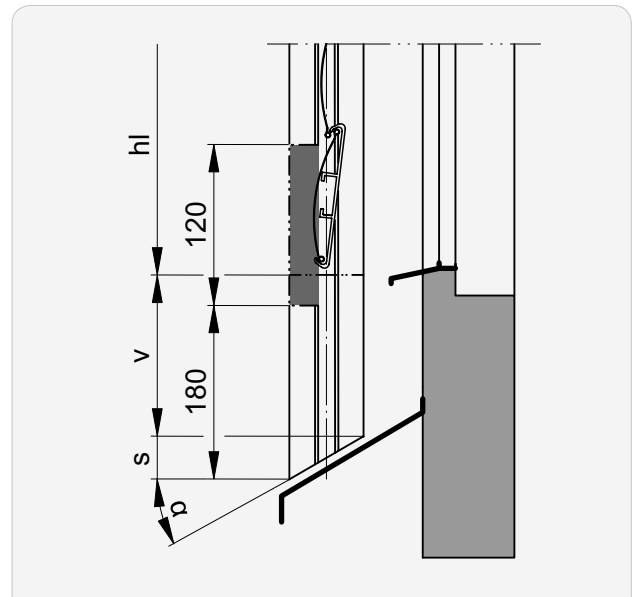

- s** Faceting (guide rail width x $\tan \alpha$)
- v** Guide rail extension: max. 3000

Fastening points



Without extension

Z	AS
≤ 1500	2
1501 ... 2700	3
2701 ... 3900	4
3901 ... 5100	5
> 5100	6

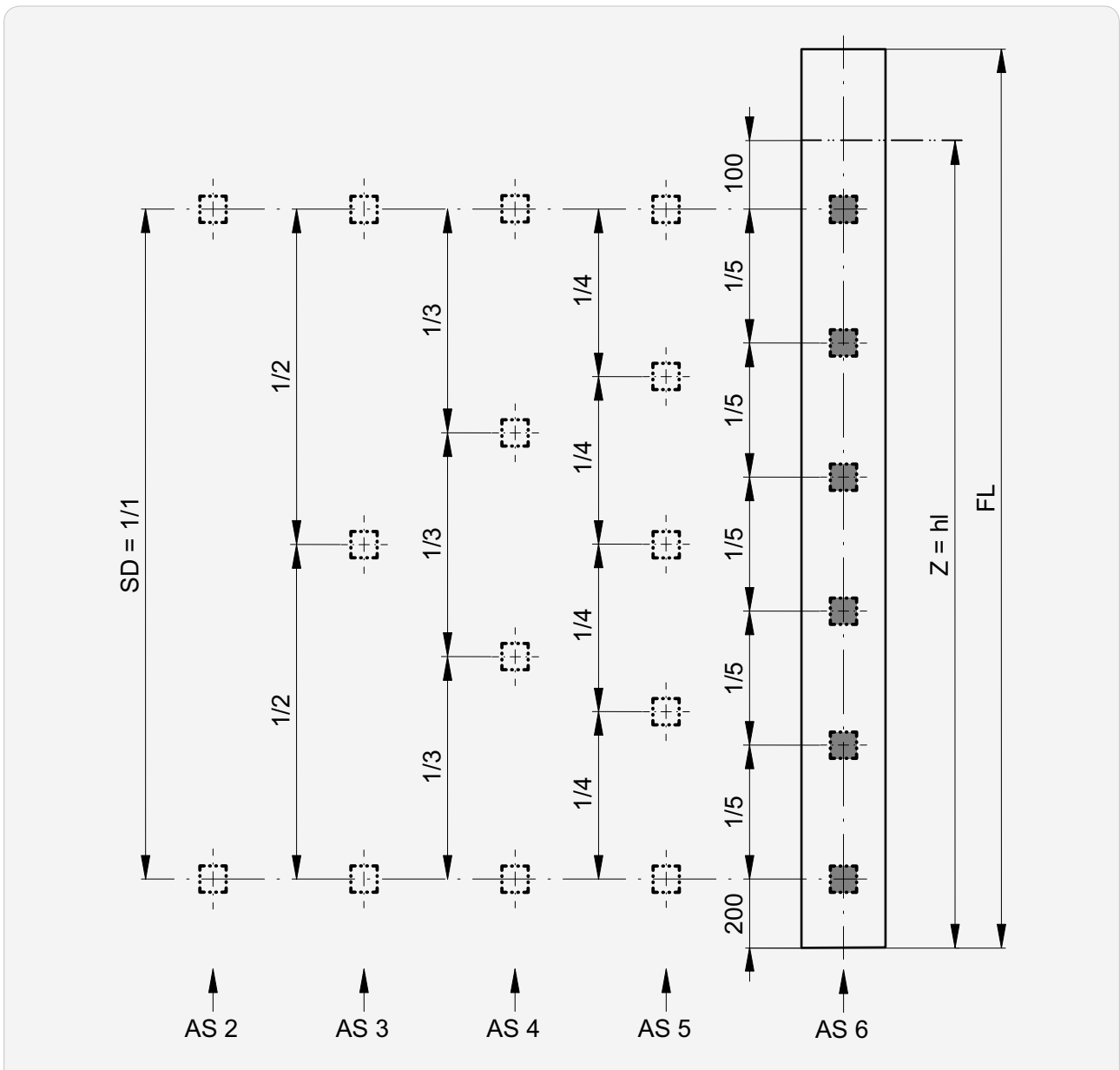

AS Number of slits

SD Slot spacing: max. 1200

►► Fastening points

With guide rail extension

Z	AS
≤ 1500	2
1501 ... 2700	3
2701 ... 3900	4
3901 ... 5100	5
> 5100	6

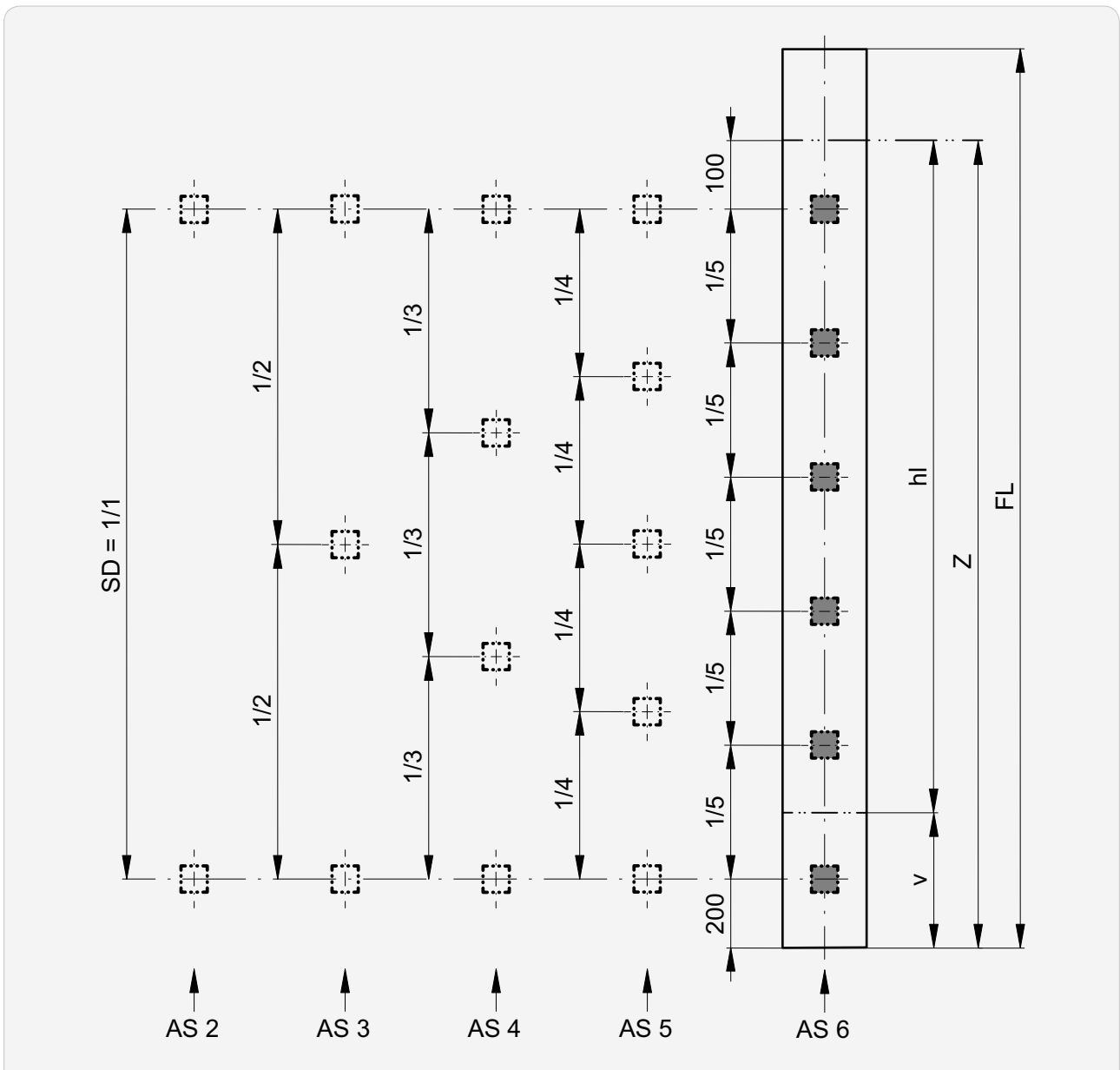

AS Number of slits
SD Slot spacing: max. 1200

v Guide rail extension: max. 3000

► Guide extension and facet.....	276	► Installation window.....	282
► Guide rail fastenings	268		

►► Fastening points

With facet

Z	AS
≤ 1500	2
1501 ... 2700	3
2701 ... 3900	4
3901 ... 5100	5
> 5100	6

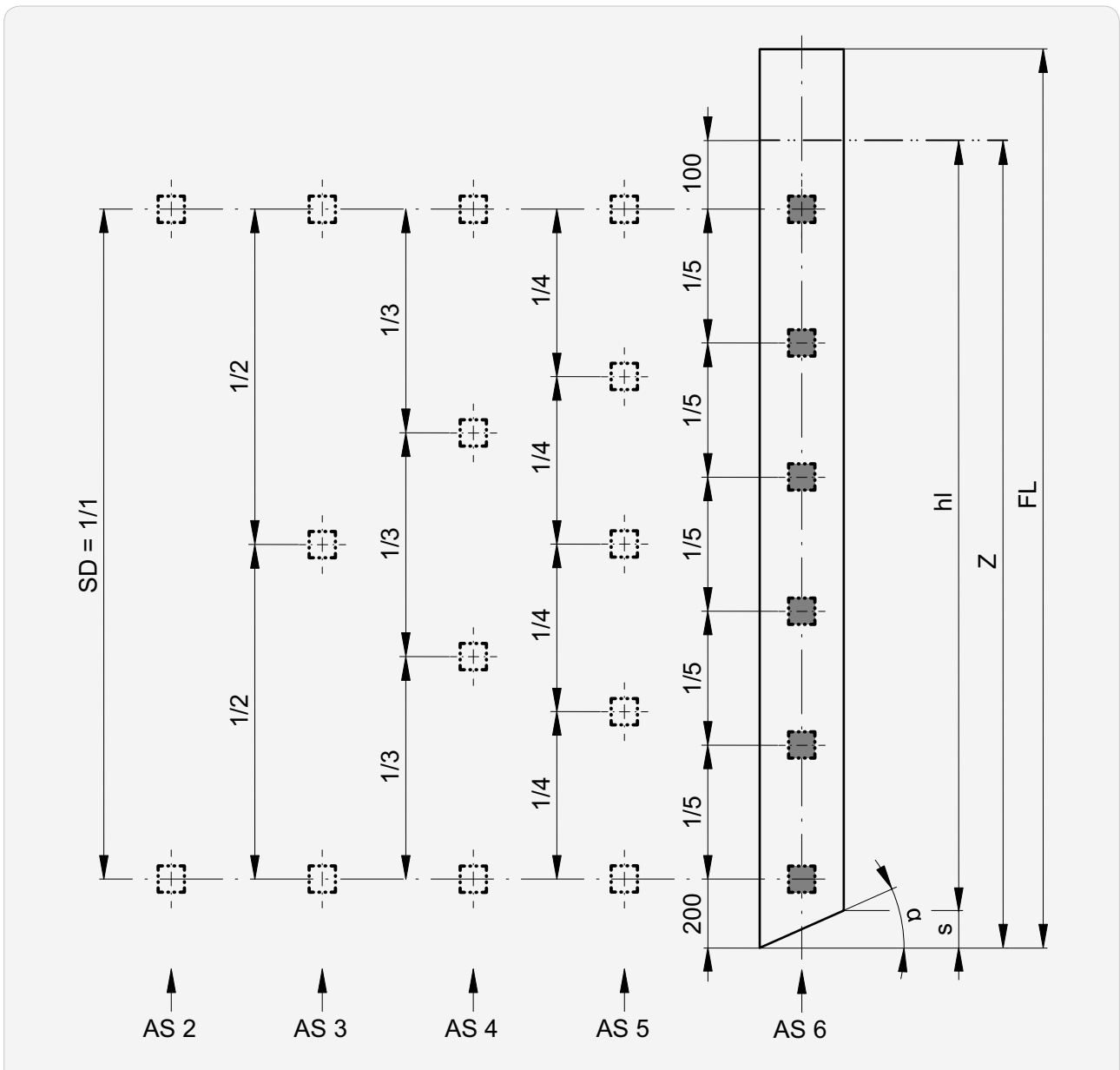

AS Number of slits

SD Slot spacing: max. 1200

s Faceting (guide rail width x tgα)

► Guide extension and facet 276
 ► Guide rail fastenings 268

► Installation window 282

►► Fastening points

With guide rail extension and facet

Z	AS
≤ 1500	2
1501 ... 2700	3
2701 ... 3900	4
3901 ... 5100	5
> 5100	6

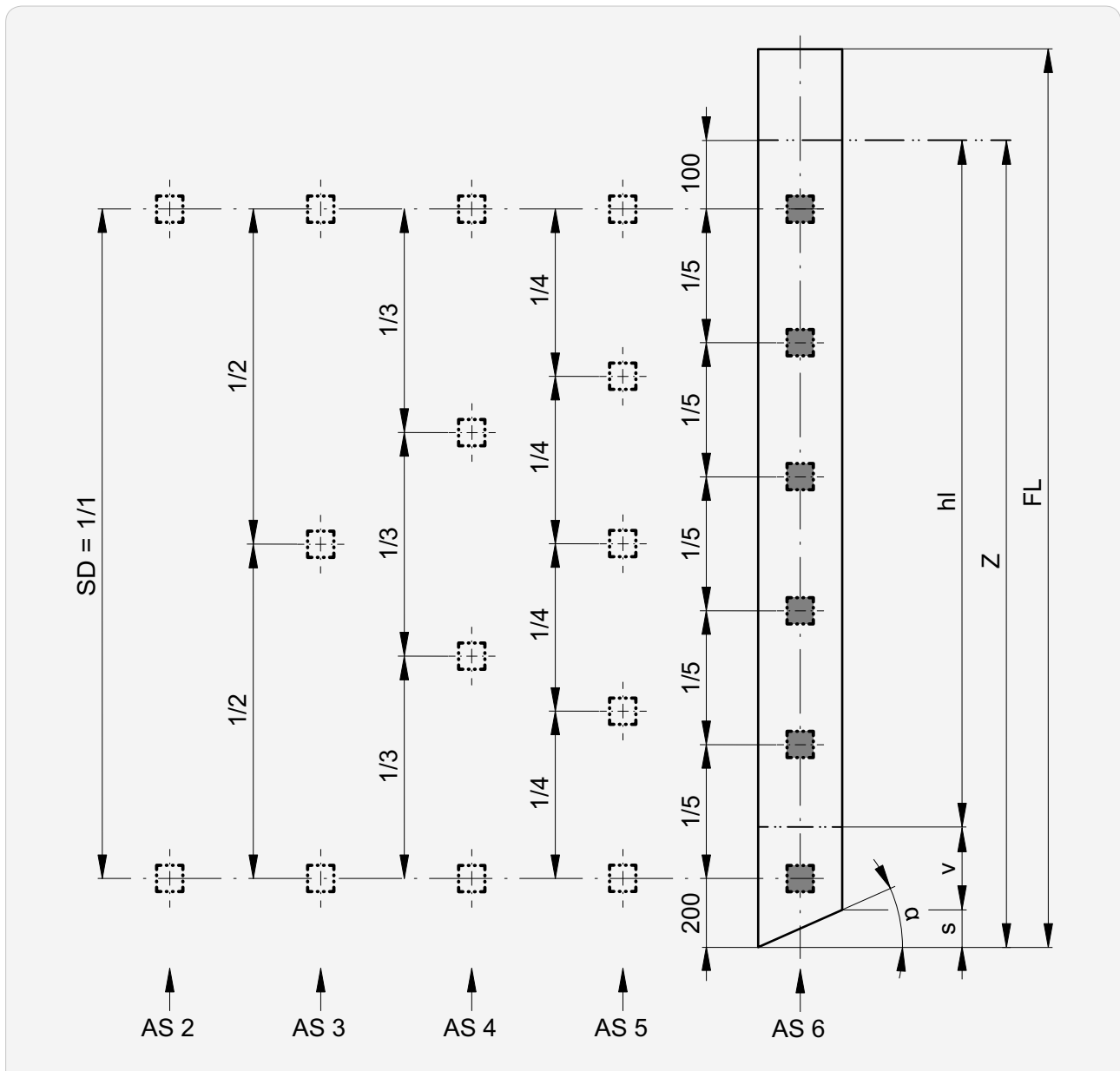

AS Number of slits

s Faceting (guide rail width x tgα)

SD Slot spacing: max. 1200

v Guide rail extension: max. 3000

► Guide extension and facet 276

► Guide rail fastenings 268

► Installation window 282

Connected systems

System width

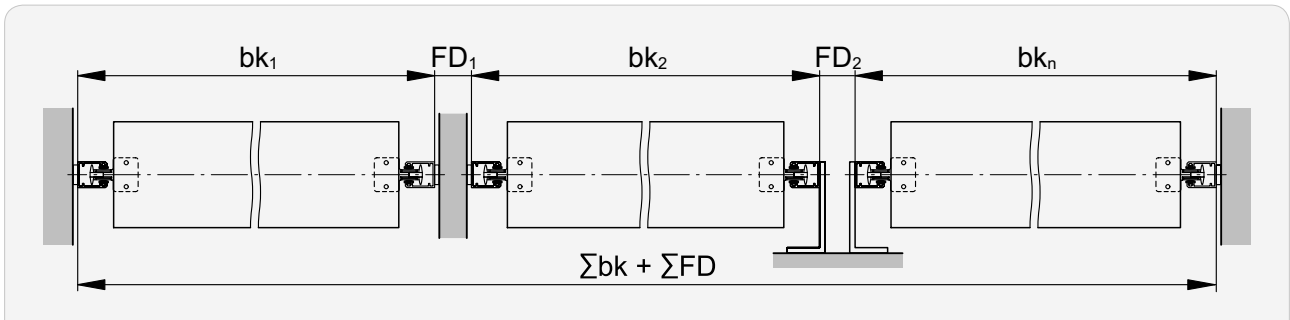

Distance between guides FD

Single guide | Fix guide

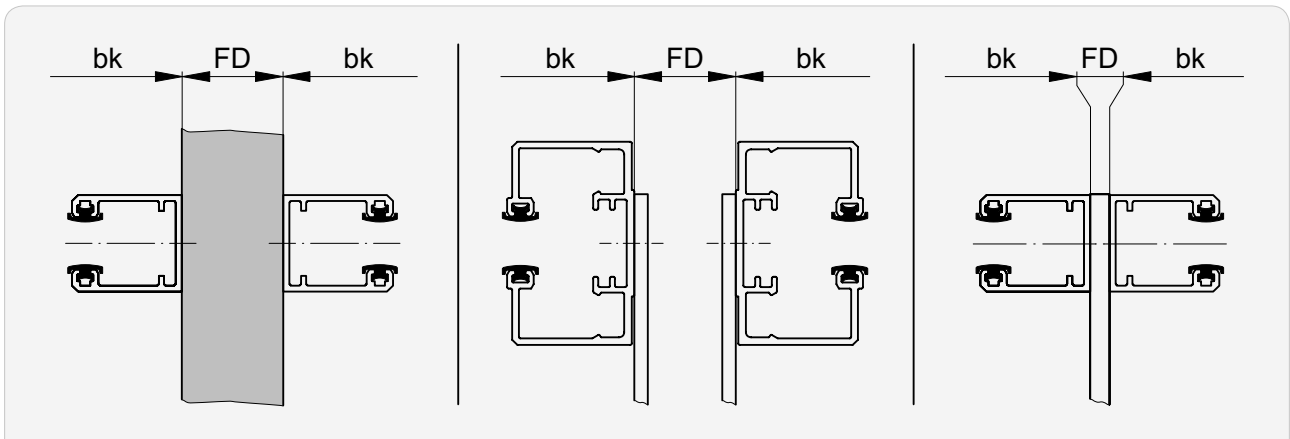

FD min.	FD max.
5	1000

Double guide

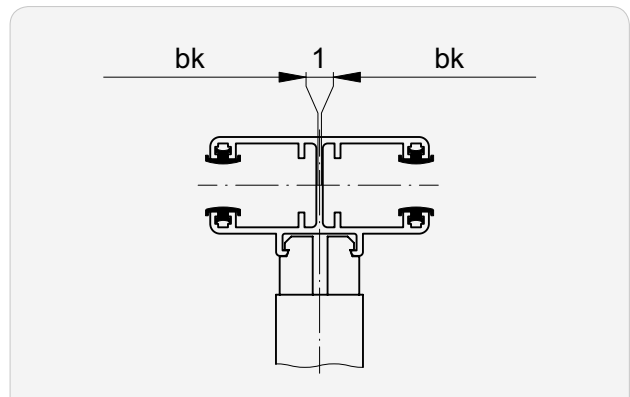
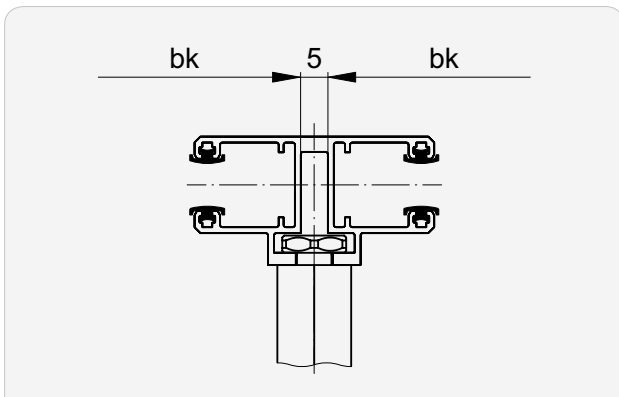

➔ Opening for connected blinds 288

►► Connected systems

Drive position

Gearbox

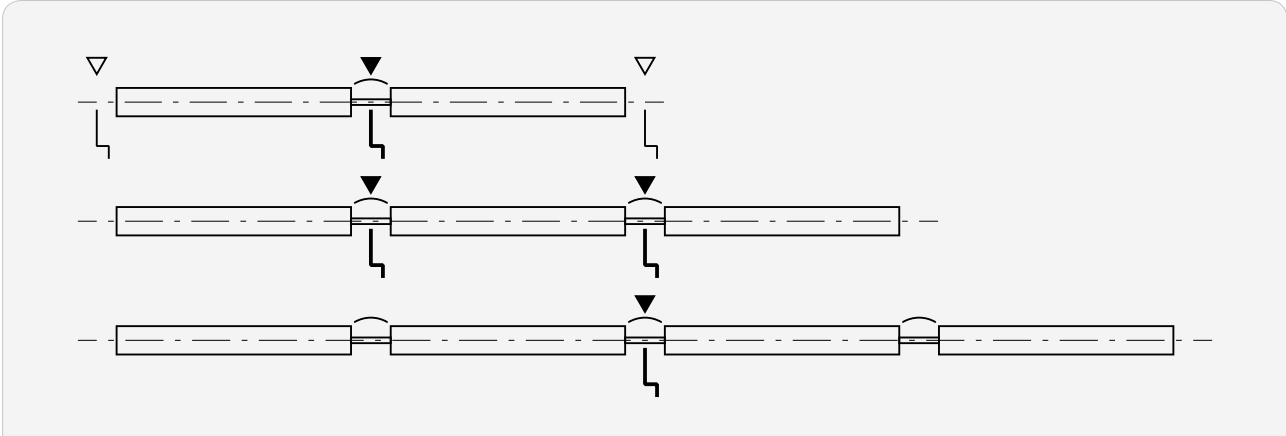

Motor

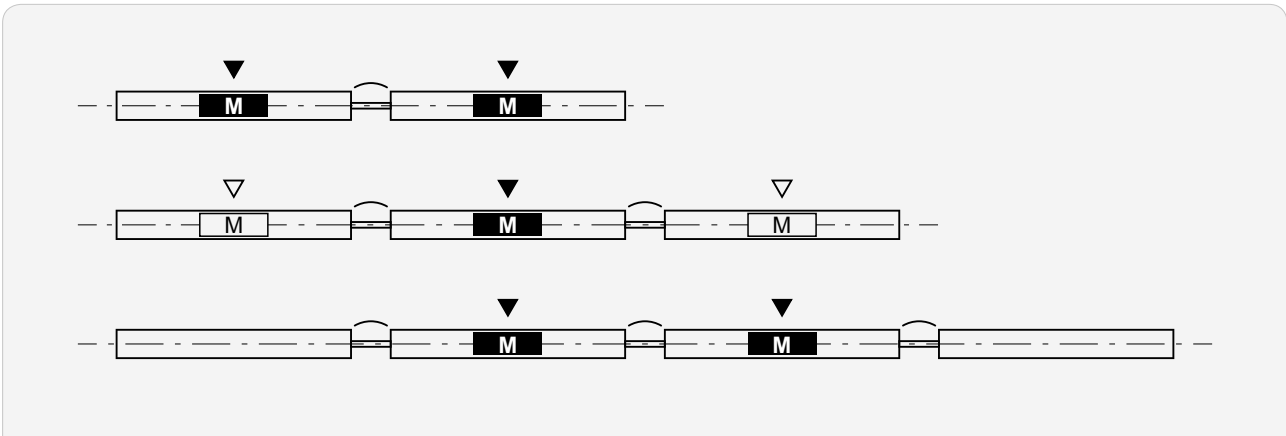

▼ Standard drive position

▽ Possible drive position

Opening for connected blinds

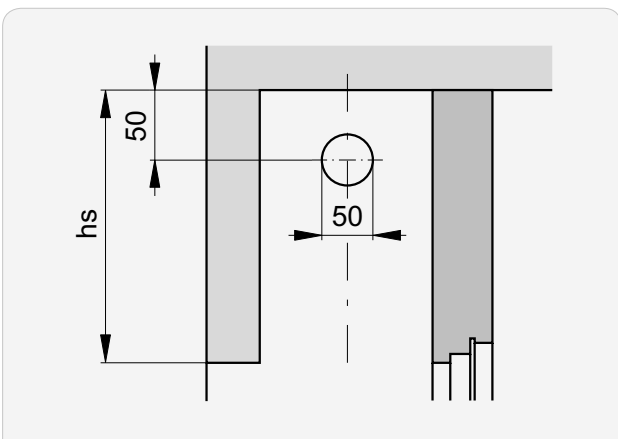

Cable guide

Soffit-/facade mounting

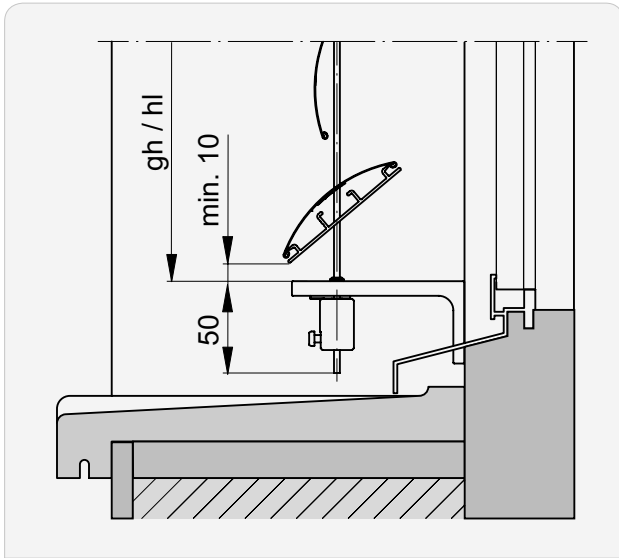

Window ledge mounting

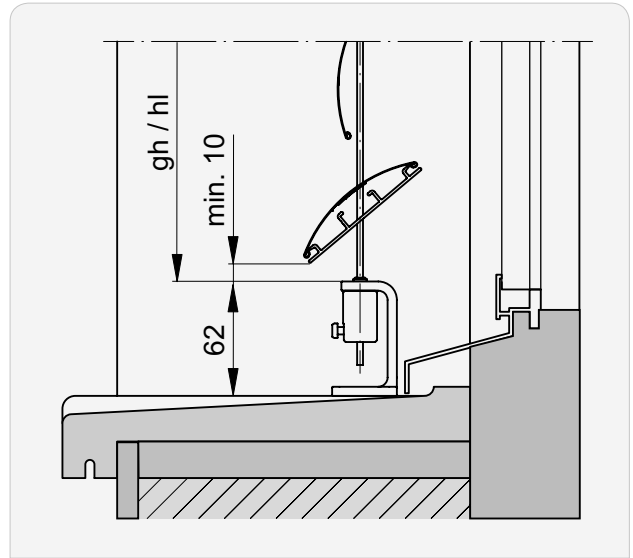

➔ Cable fastenings..... 298

➔ Distance between guides **FD**..... 300

Sections | Details

Horizontal section

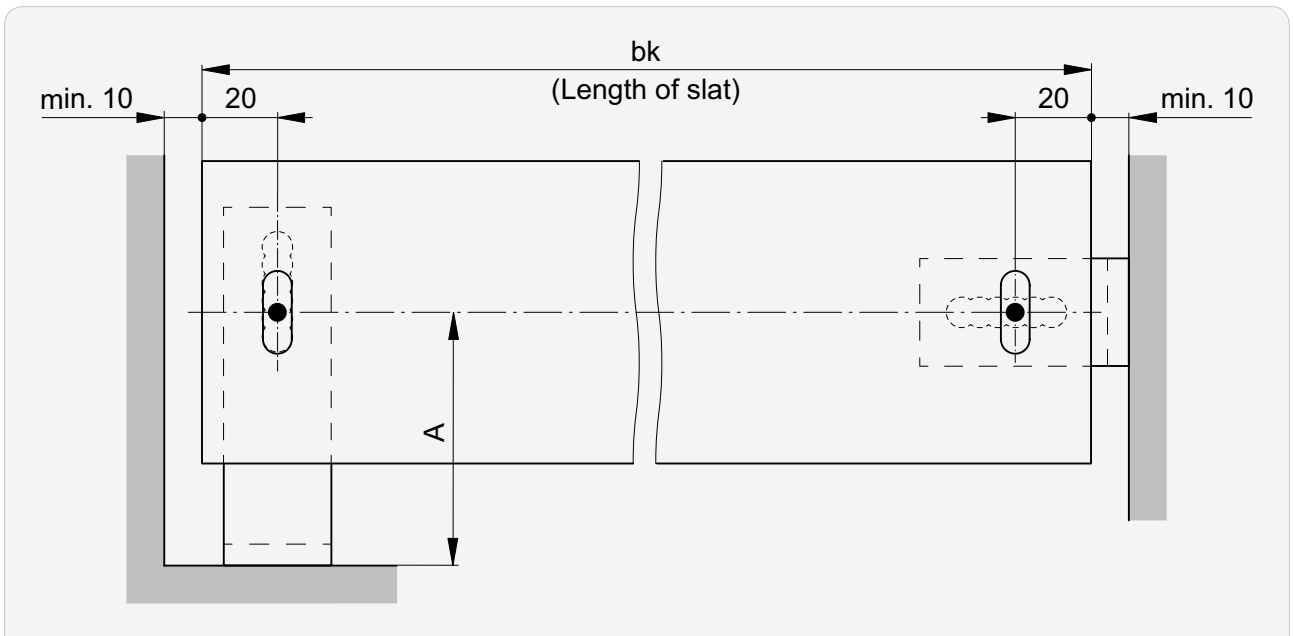

➔ Value for **A**..... 247

►► Sections | Details

Horizontal section: Box

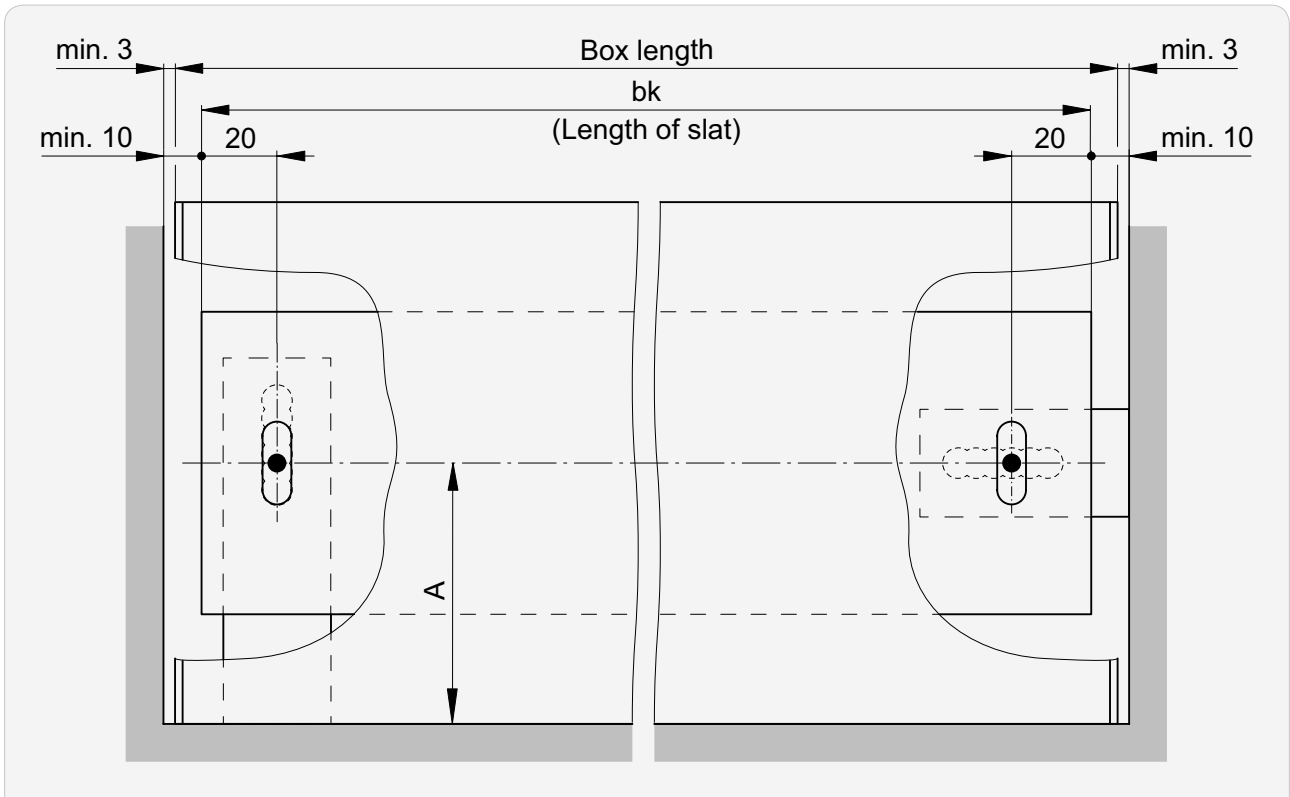

➔ Value for **A** 247

Horizontal section: Box extension

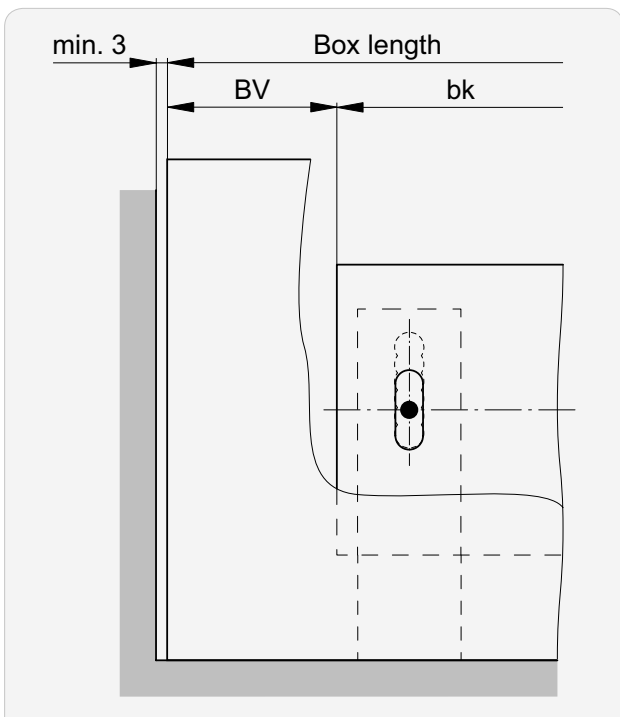

Sections for crank drive (MBMA)

outside bk

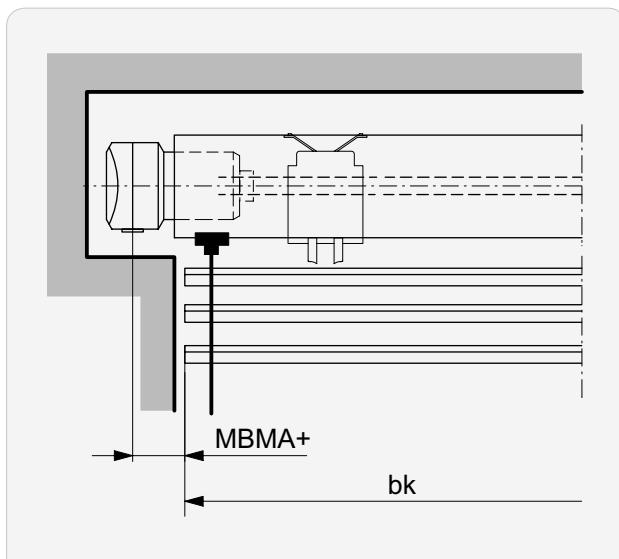

MBMA+¹

20 ... 999

¹ With 20 ... 44, provide sufficient niche depth for the box extension (min. 80).

within bk

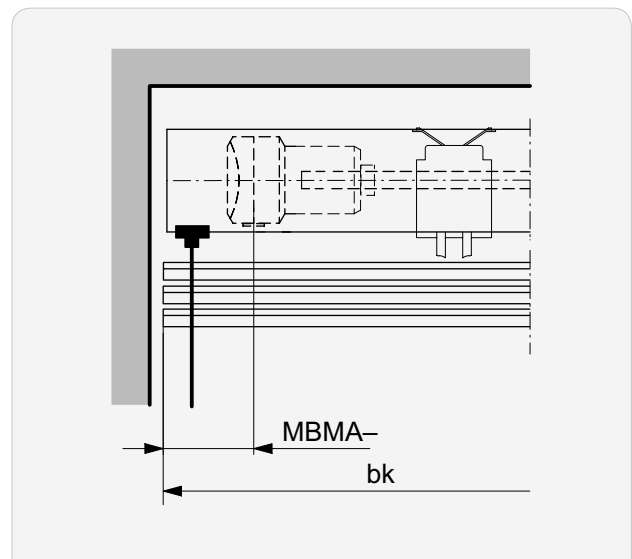

MBMA-

80 ... (bk/2)

Additional cables

i **Additional cables must be fitted for a $bk > 3000$ and in locations which are exposed to high wind.**
 The dimensions **P1** and **P2** are **measured from the left from bk and must be noted on the dimensions sheet.**
 P2 does not apply for the first additional cable.

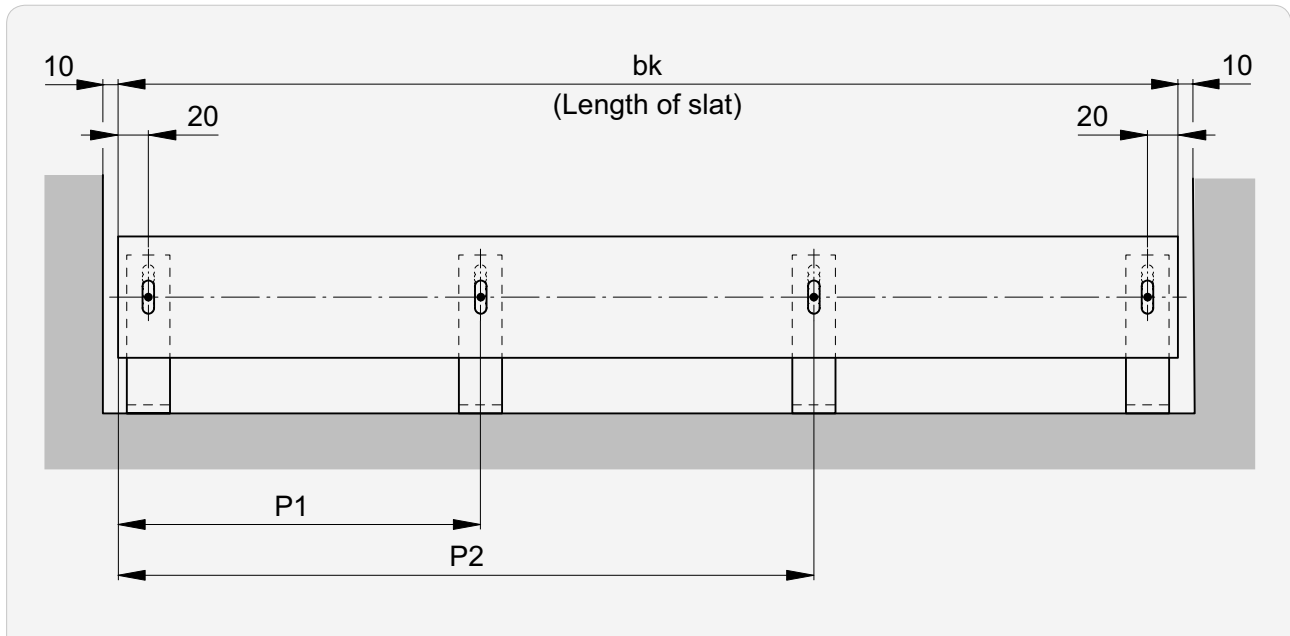

- P1** Position of first cable or cable on left
- P2** Position of cable on right

Number of additional cables

i **If no information is provided for $P1$ or $P2$, they are positioned according to the following table.**

Width max. (bk)	Number of additional cables	P1	P2
≤ 3000	0	–	–
3001 ... 4000	1	$(bk/2)$	–
> 4000	2	$(bk/3)$	$2 (bk/3)$

Vertical connections | Standard motor position

Number of bearings

Solomatic® II 70

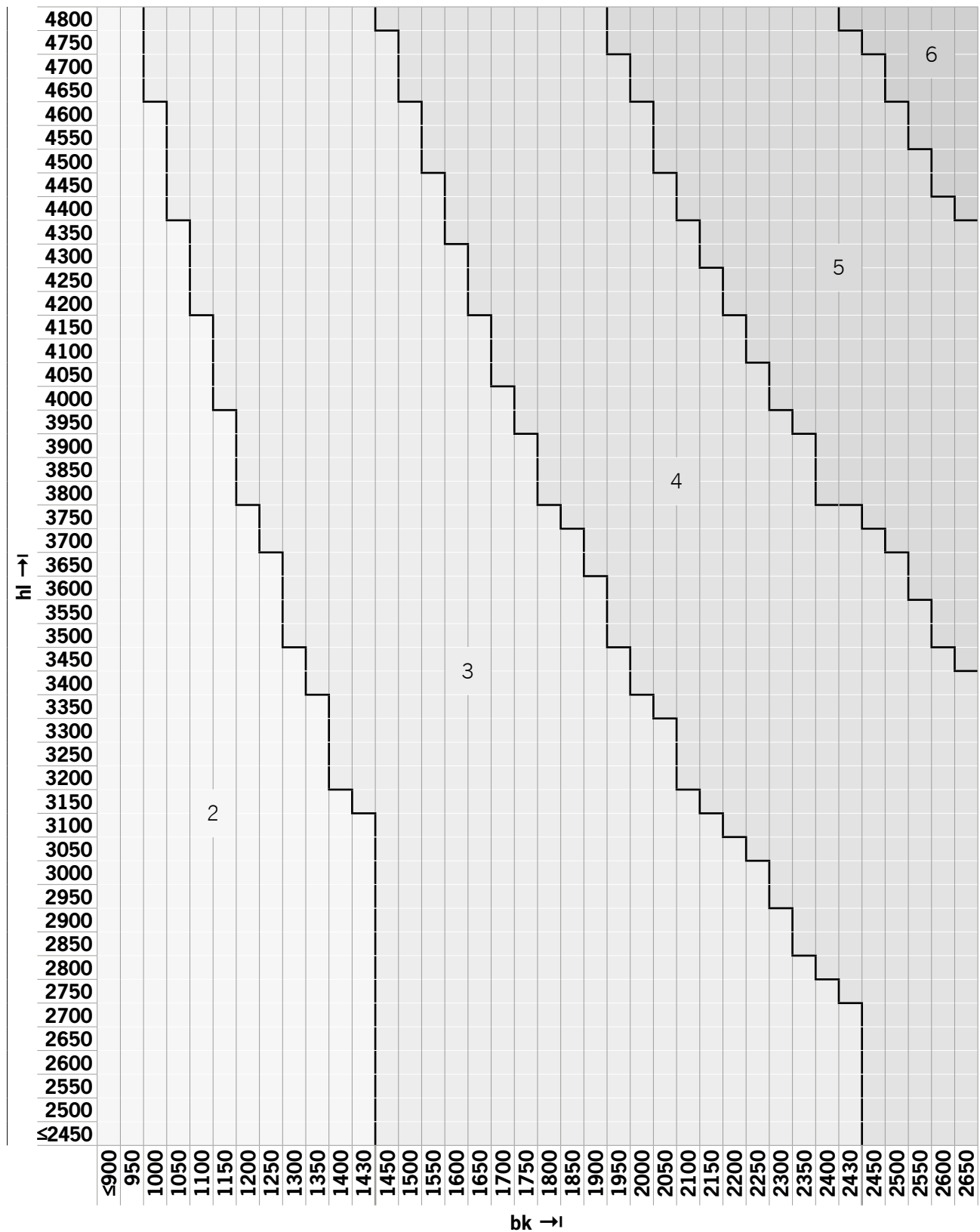

Standard motor position 297

►► Vertical connections | Standard motor position

Number of bearings

Solomatic® II 70

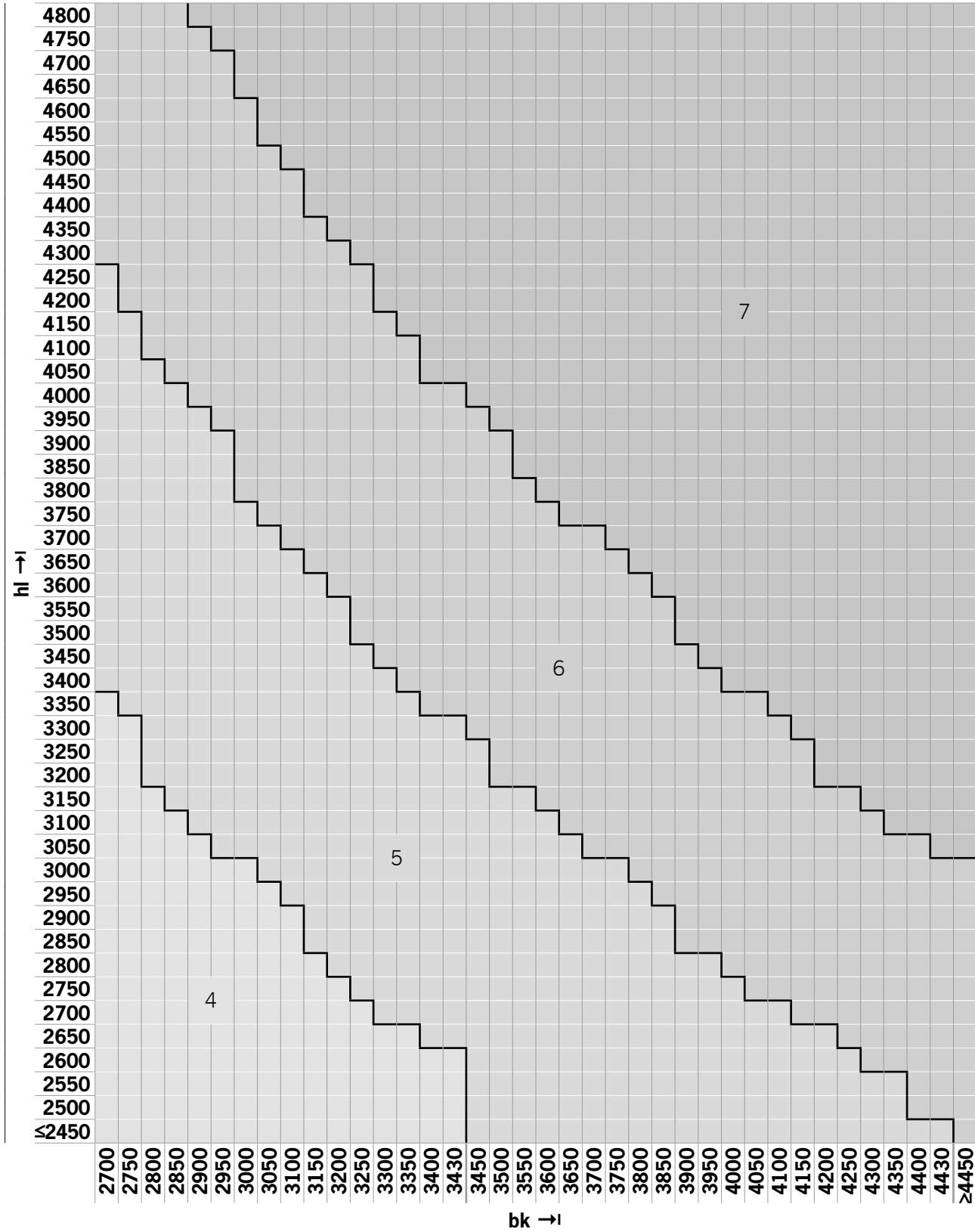

►► Vertical connections | Standard motor position

Number of bearings

Solomatic® II 80

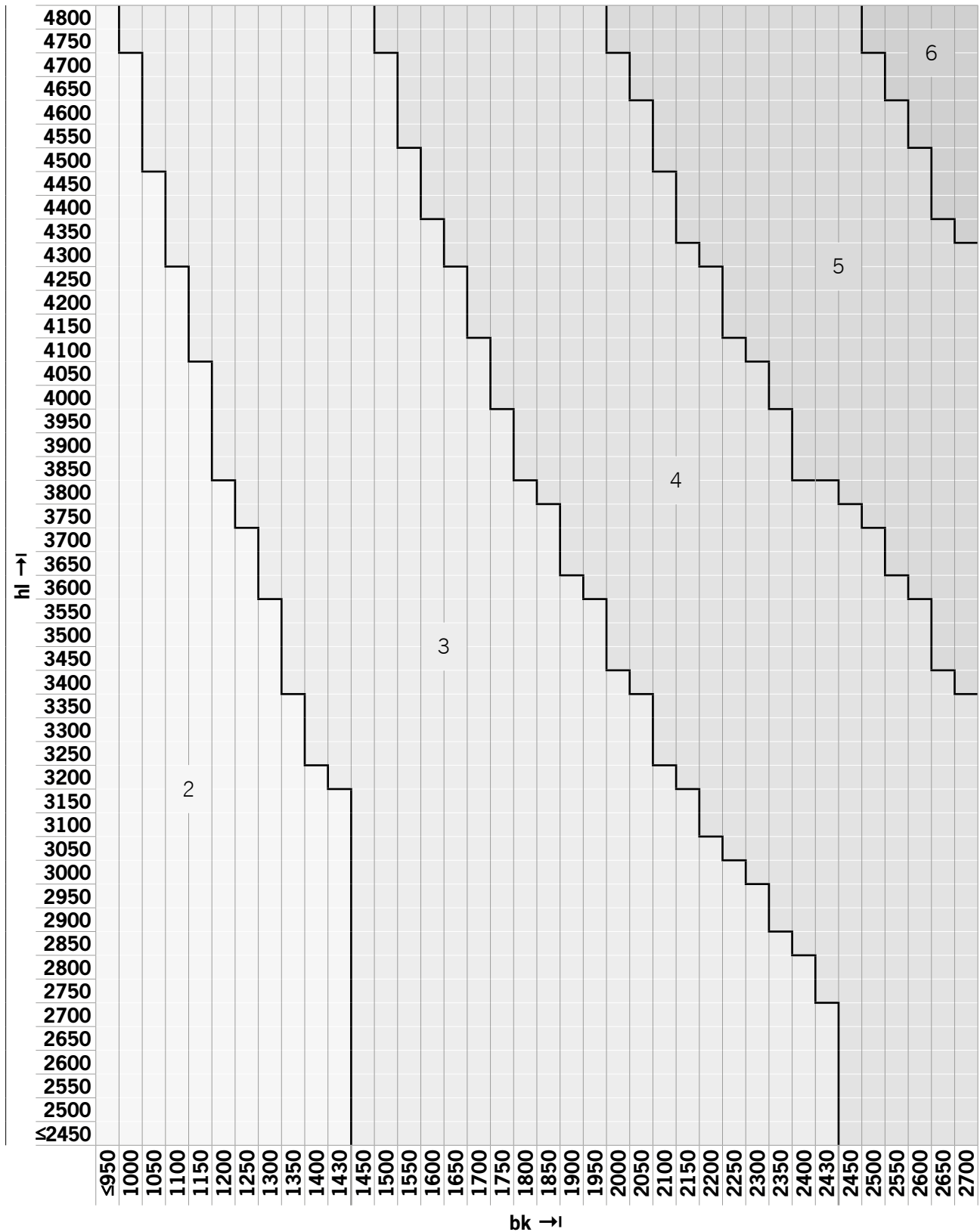

► Standard motor position 297

►► Vertical connections | Standard motor position





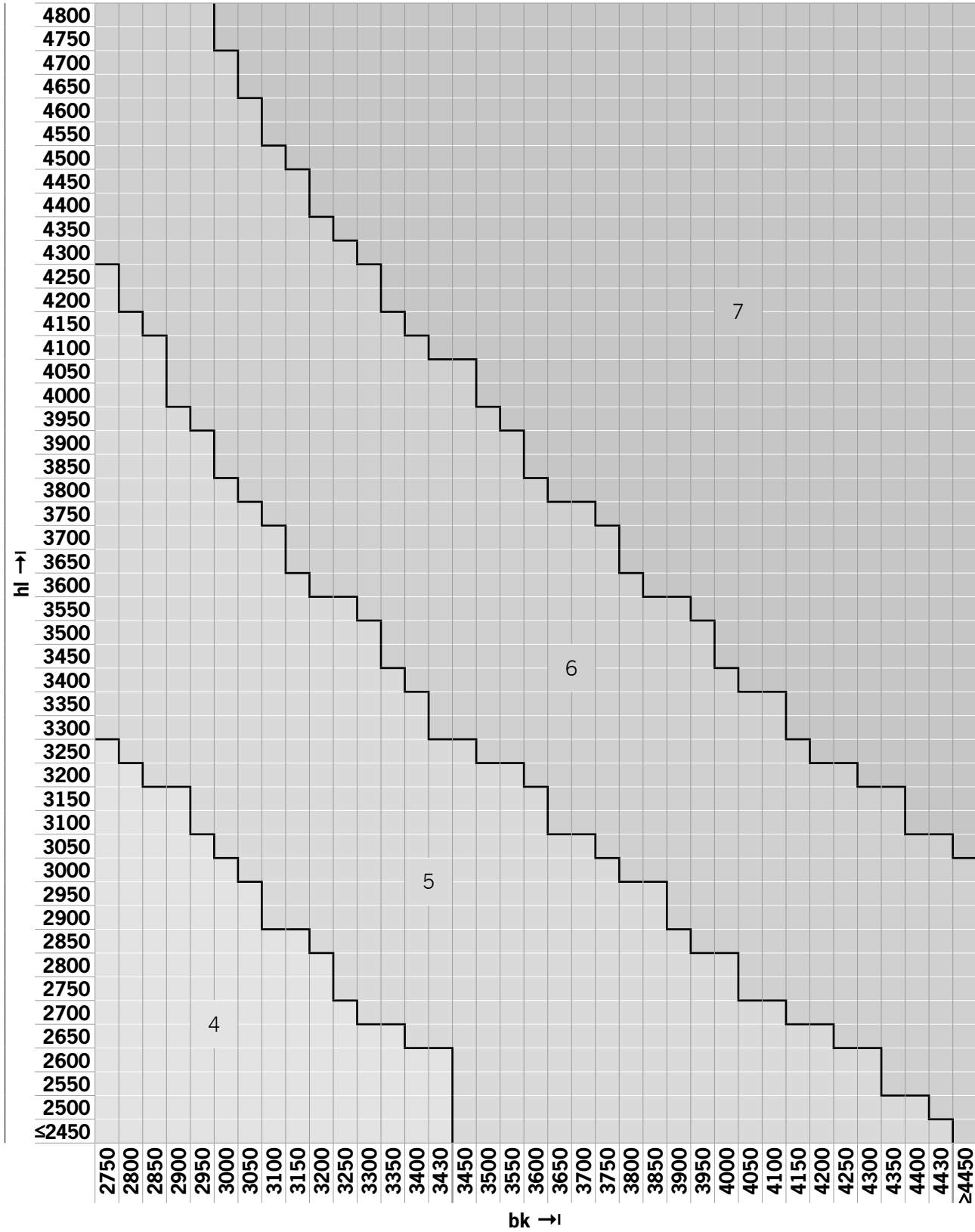

Number of bearings



Solomatic® II 80



▶▶ Vertical connections | Standard motor position

Standard motor position

Number of bearings	Standard motor position
2	
3	
4	
5	
6	
7	

-  Bearing
-  Standard motor position
-  Possible motor position (on request)

Cable fastenings

S Soffit or facade installation

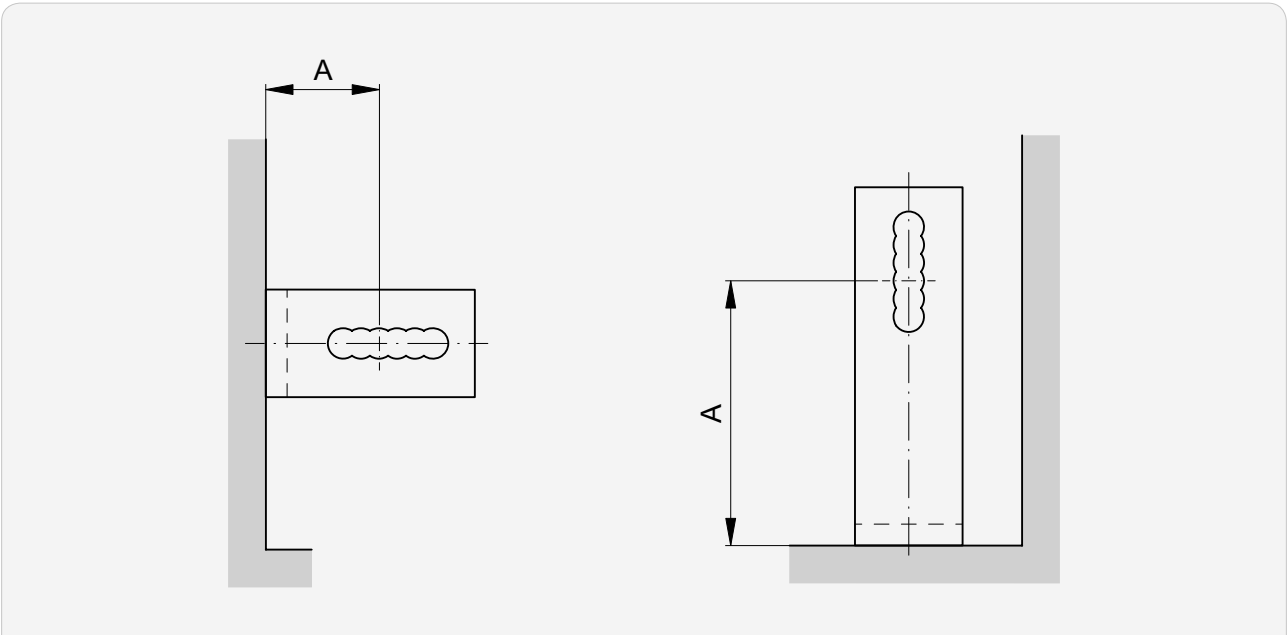

Tensioning bracket 20–40 for type S

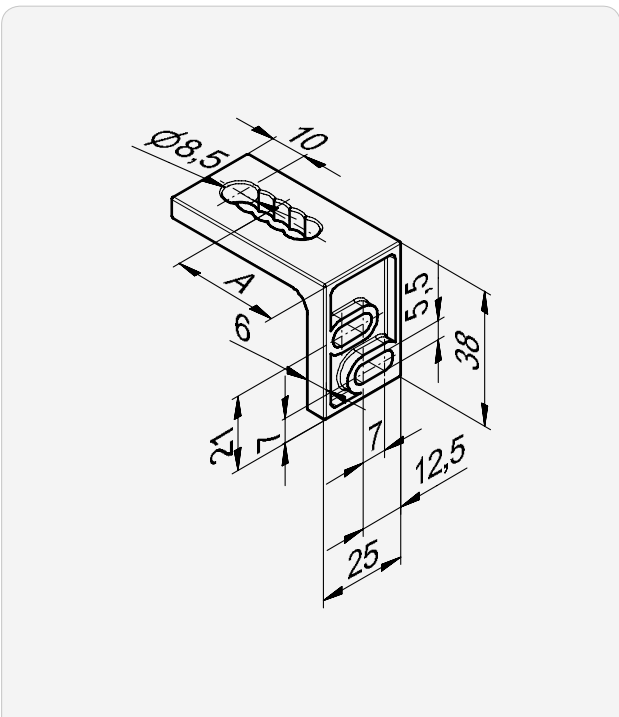

A*
20...40

Tensioning bracket 45–70 for type S

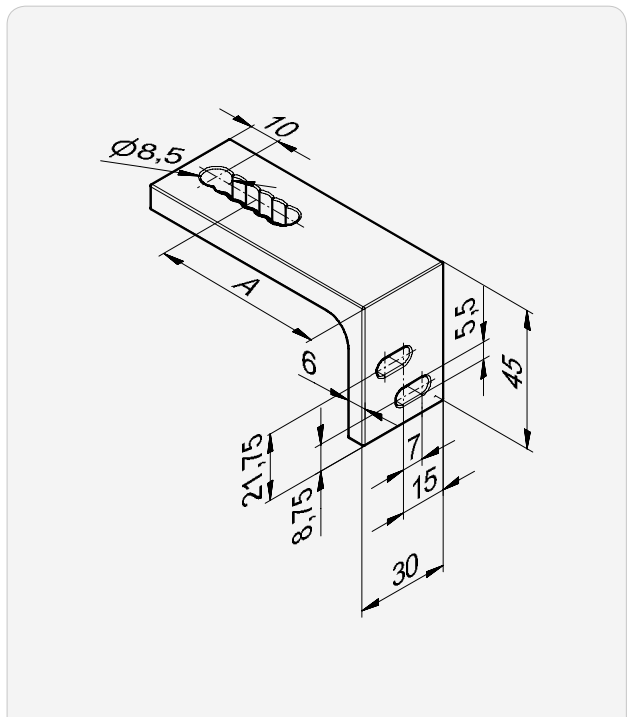

A*
45...70

* in 5 mm steps

►► Cable fastenings

Tensioning bracket 75–130 for type S

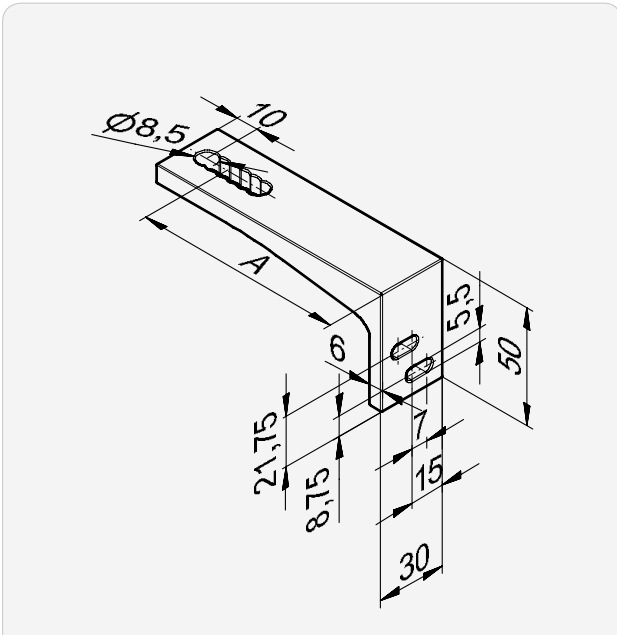

A*

75 ... 100

105 ... 130

Tensioning bracket 135–190 for type S

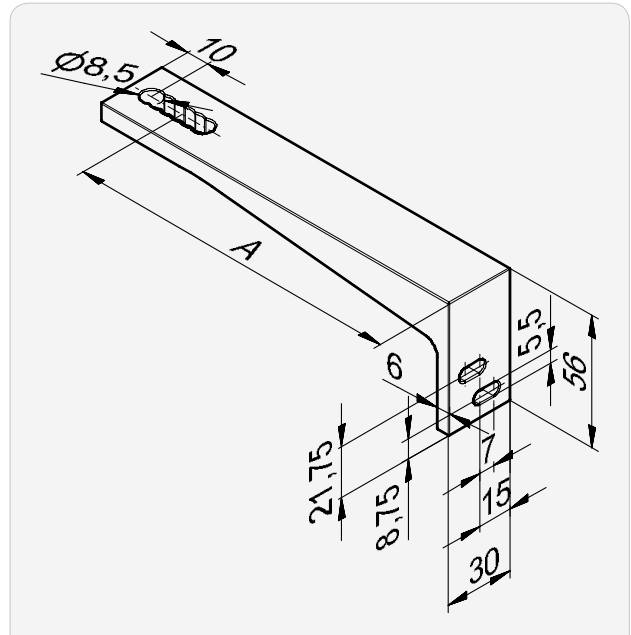

A*

135 ... 160

165 ... 190

* in 5 mm steps

NU Windowsill installation

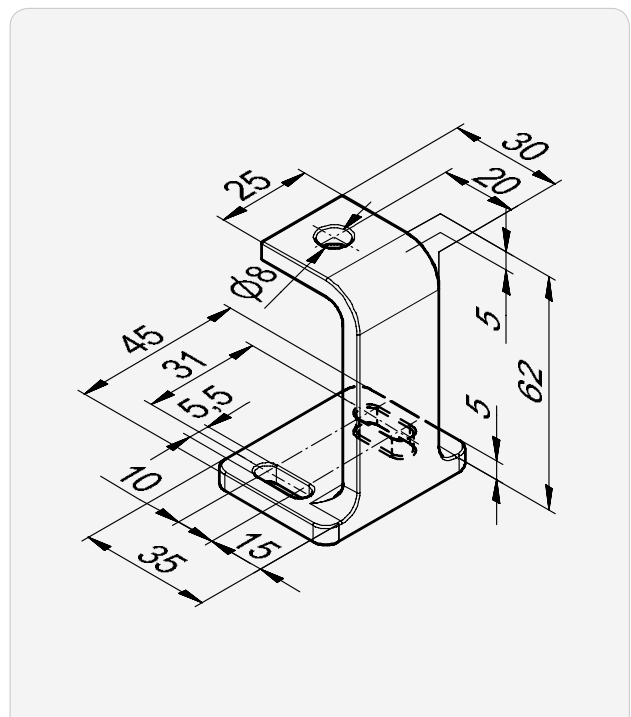
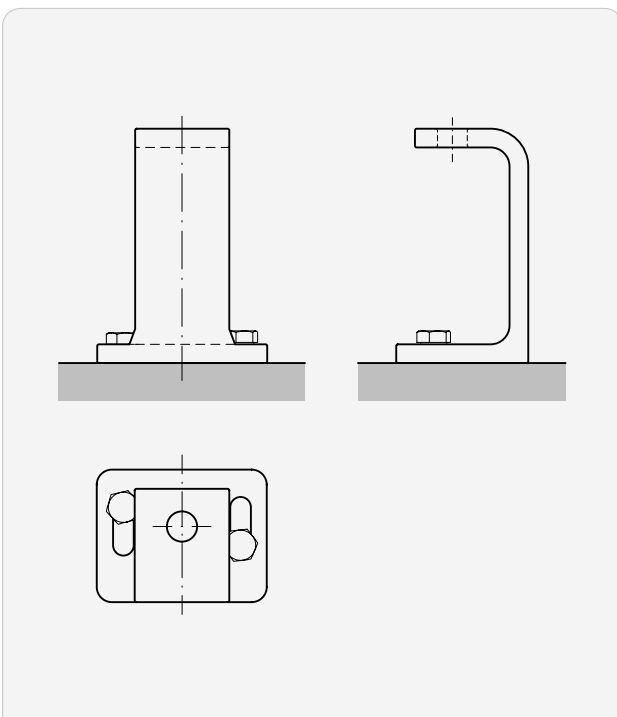

Connected systems

System width

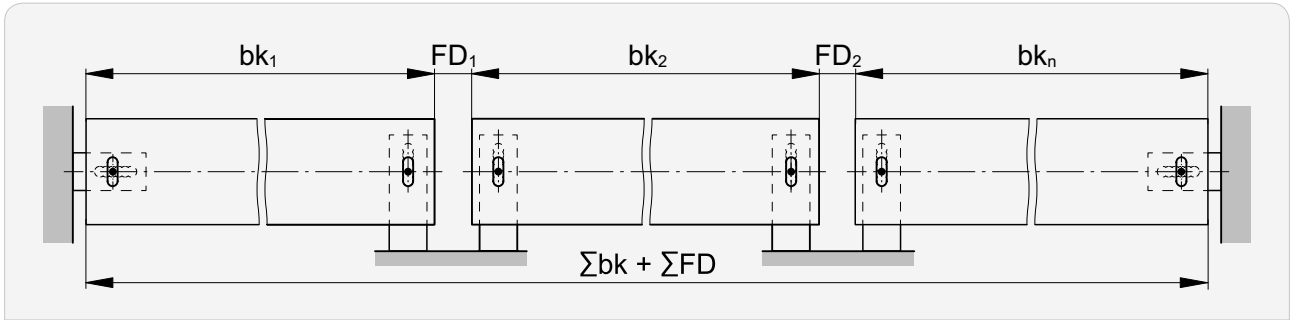

Distance between guides FD

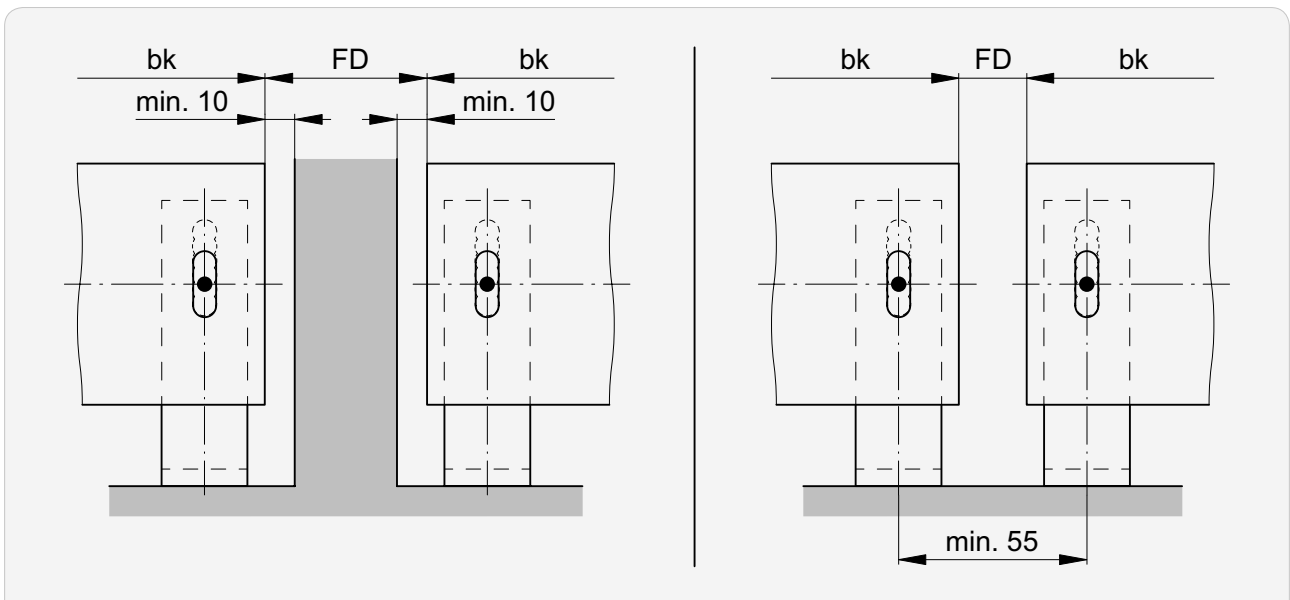

FD min.	FD max.
15	1000

►► Connected systems

Drive position

Gearbox

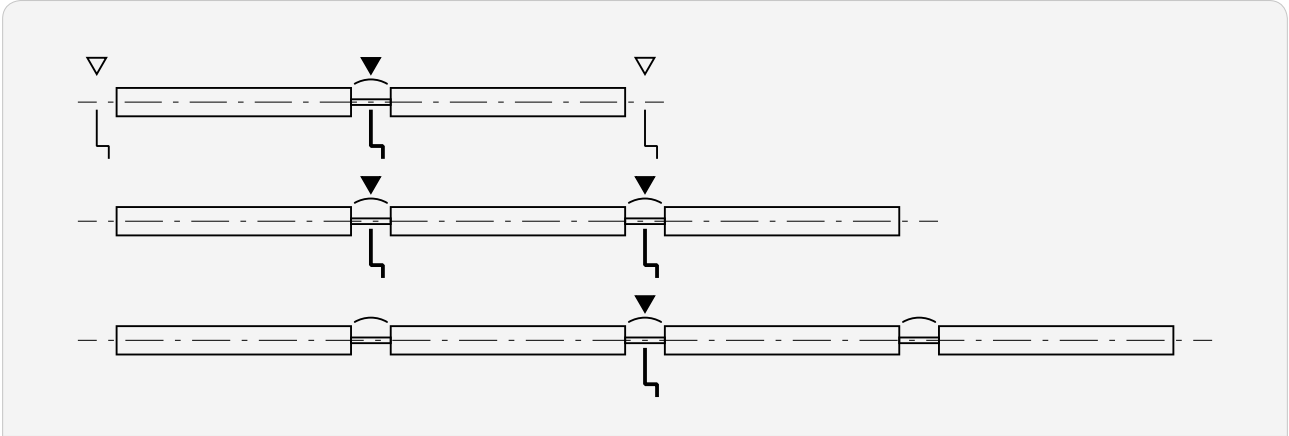

Motor

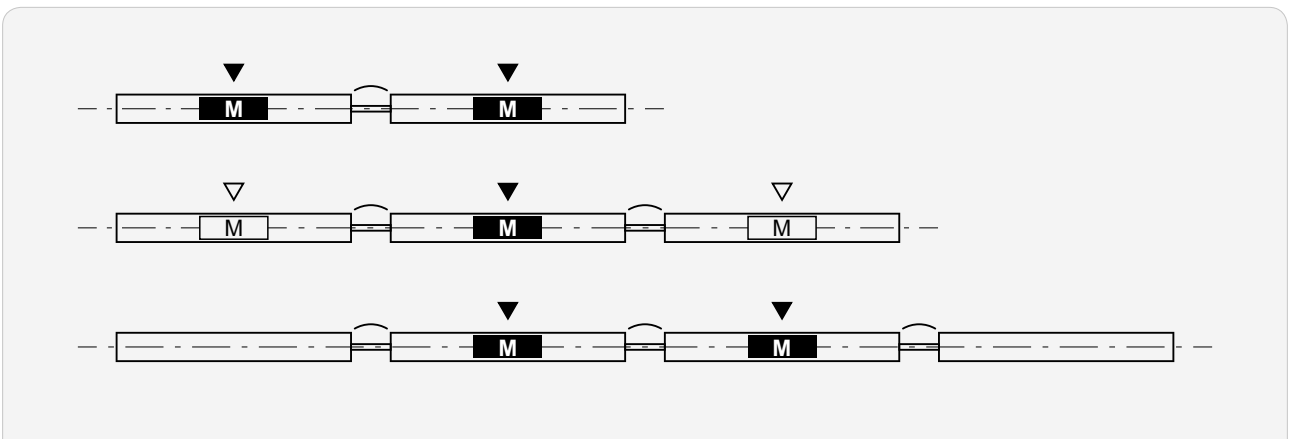

▼ Standard drive position

▽ Possible drive position

Opening for connected blinds

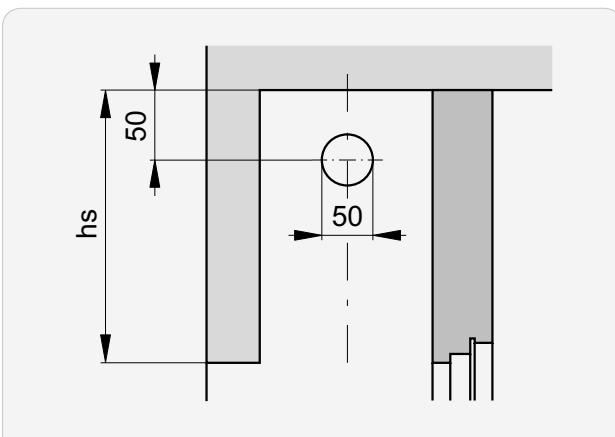

Solomatic® II System

Limit dimensions Solomatic® II System Profil	304
Limit dimensions Solomatic® II System Box	304
Built-in System	305
Installation system with Box	306
Header dimensions Heights of package	307
Slat profiles	308
End rails	308
Beginning distance Slot spacing	309
Orientation of cable outlet	310
Guide rails	311
Sections Details	312
Vertical connections Standard motor position	314
Guide rail installation (principle)	319
Guide rail fastenings (principle)	320
Guide extension and facet	321
Fastening points Solomatic® II System Profil	323
Fastening points Solomatic® II System Box	327
Technical data of motors	331



Limit dimensions Solomatic® II System Profil

Single blind

Operation	Width min. (bk)	Width ¹ max. (bk)	Height min. (hl)	Height max. (hl)	Surface max. [m ²]
Motor drive	600 630 ²	4500 ³ 5000 ⁴	440 ³ 390 ⁴	4500 ³ 5000 ⁴ 4000 ²	15

Limit dimensions Solomatic® II System Box

Single blind

Operation	Width min. (bk)	Width ¹ max. (bk)	Height min. (gh)	Height max. (gh)	Surface max. [m ²]
Motor drive	600 630 ²	4000	590 ³ 630 ⁴	4845 4349 ^{2,3} 4319 ^{2,4}	15

¹ For buildings and high-rise structures, which are exposed to high winds, this maximum value should be decreased as required. Also see wind classes data sheet.

² Radio motor Geiger AIR

³ Solomatic® II 70 System

⁴ Solomatic® II 80 System

Built-in System

Vertical section: Solomatic® II 70 System Profil

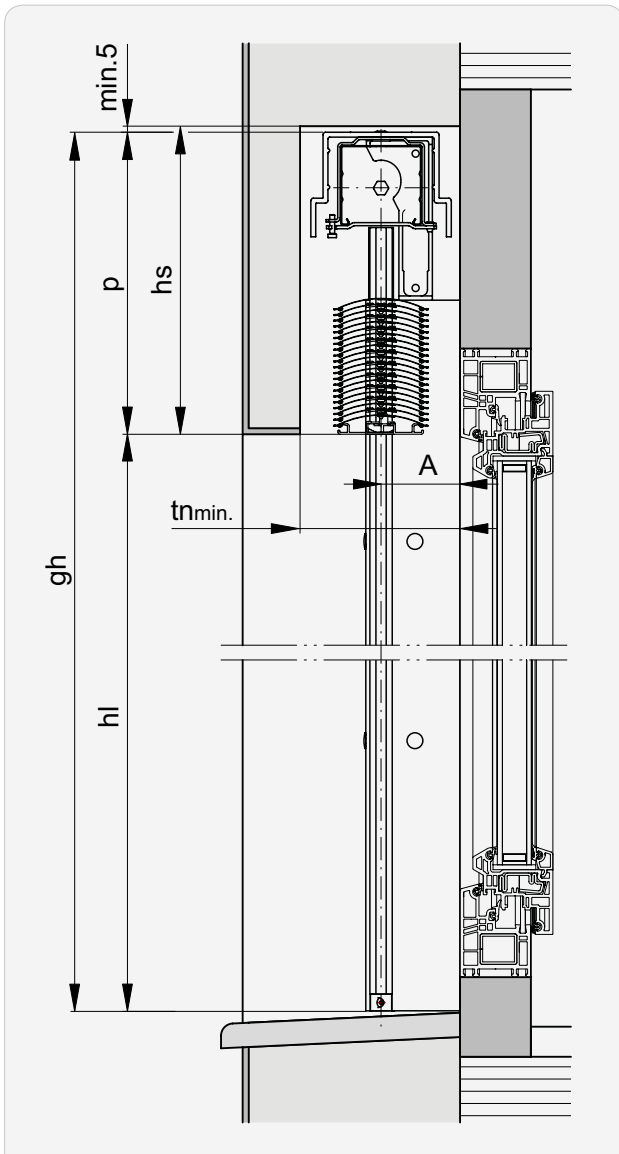

Vertical section: Solomatic® II 80 System Profil

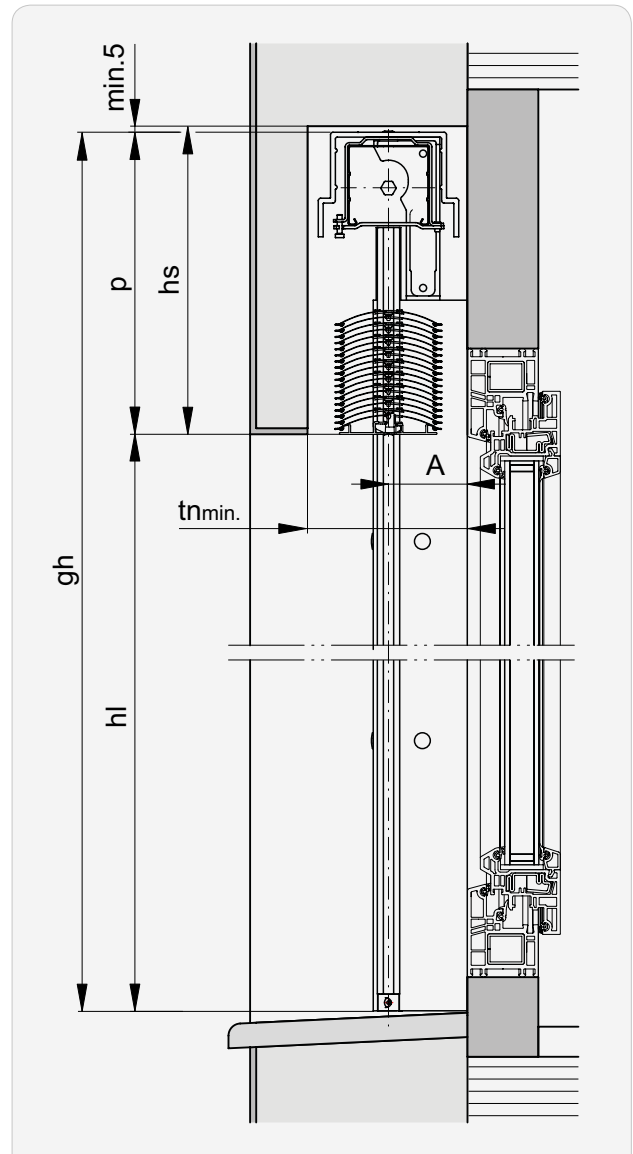

Horizontal section: Solomatic® II 70 System Profil

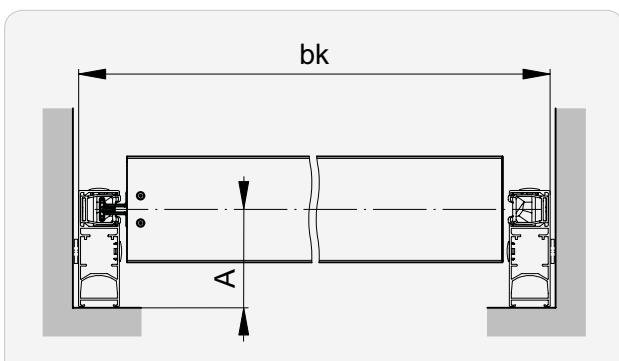

Horizontal section: Solomatic® II 80 System Profil

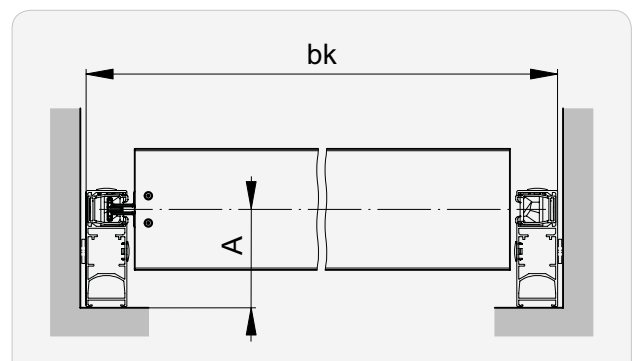

Installation system with Box

Vertical section: Solomatic® II 70 System Box

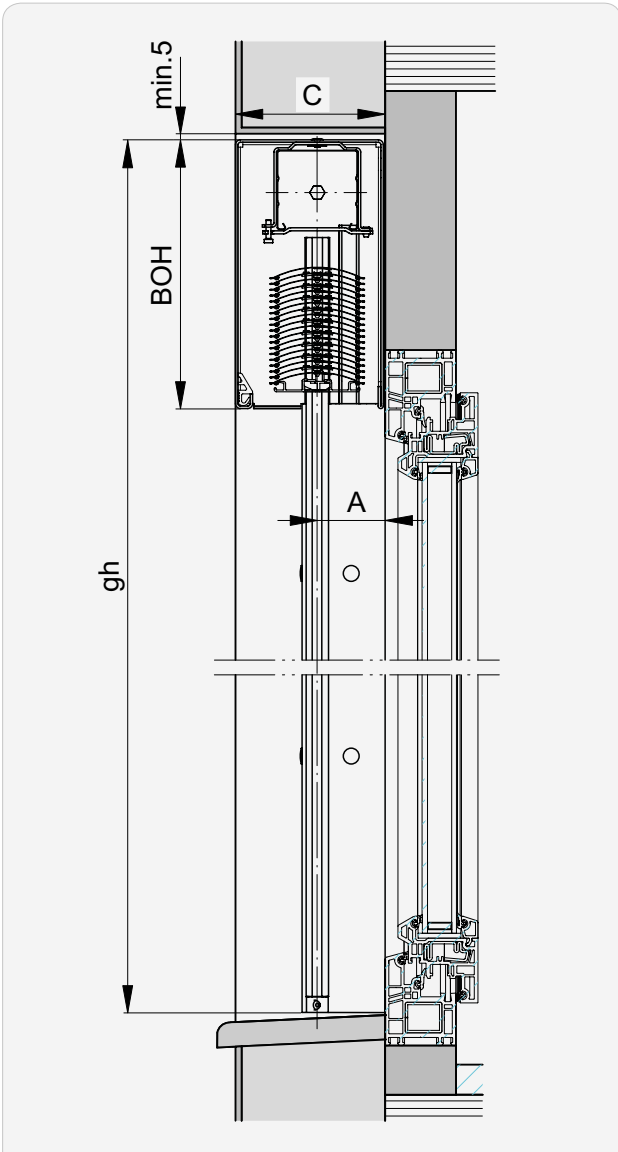

Box with slat package covered

Vertical section: Solomatic® II 80 System Box

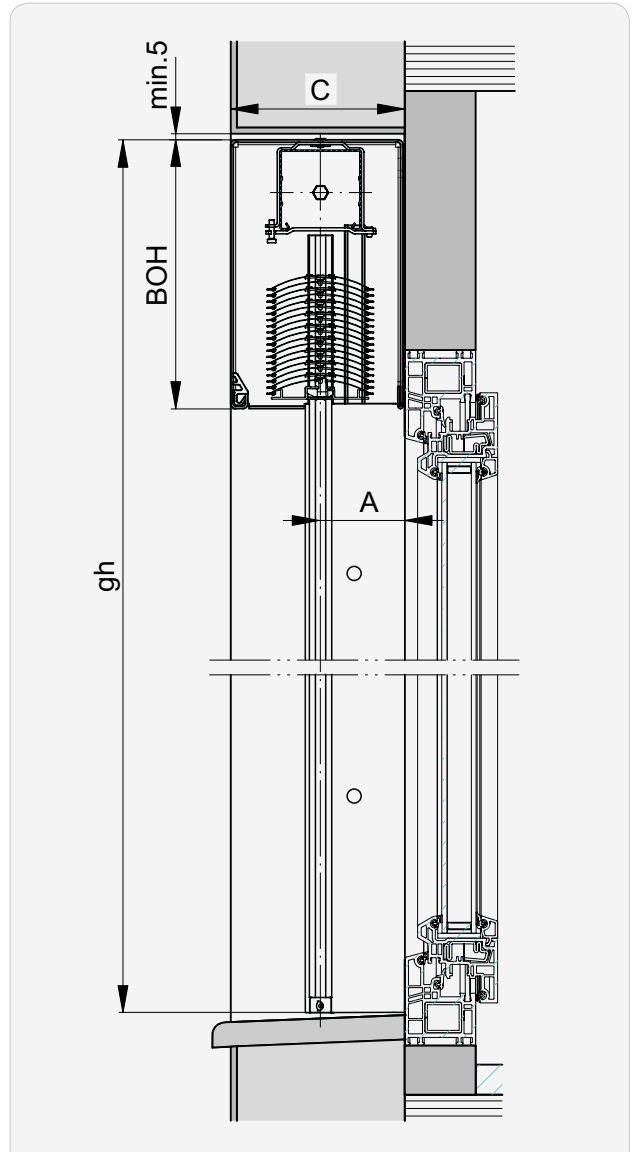

Box with slat package covered

Horizontal section: Solomatic® II 70 System Box

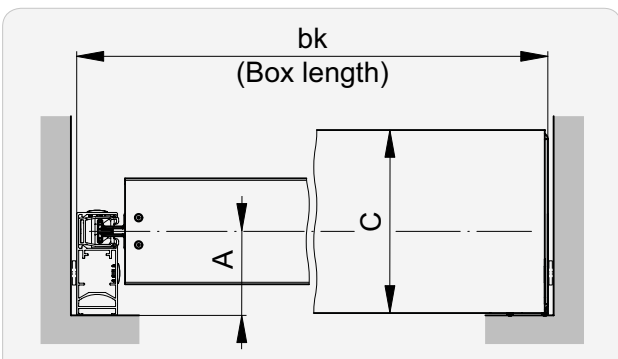

Horizontal section: Solomatic® II 80 System Box

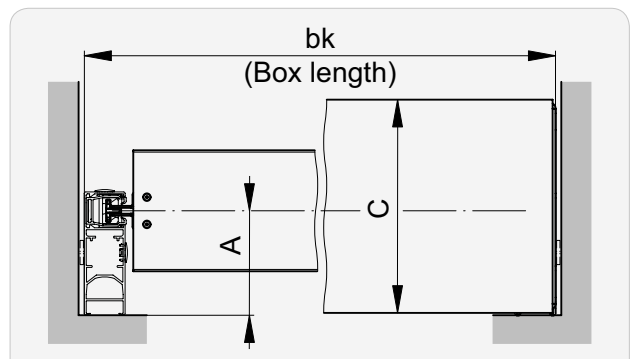

Header dimensions | Heights of package

Solomatic® II 70 System Profil

hl →l	P min.	hs	hl →l	P min.	hs
1000	175	180	3000	290	295
1250	195	200	3250	315	320
1500	210	215	3500	325	330
1750	220	225	3750	340	345
2000	235	240	4000	350	355
2250	250	255	4250	370	375
2500	265	270	4500	385	390
2750	280	285			

tn min.	A
130*	64.5

Solomatic® II 80 System Profil

hl →l	P min.	hs	hl →l	P min.	hs
1000	180	185	3000	270	275
1250	185	190	3250	280	285
1500	195	200	3500	295	300
1750	210	215	3750	305	310
2000	220	225	4000	320	325
2250	235	240	4250	335	340
2500	245	250	4500	345	350
2750	255	260			

tn min.	A
130*	64.5

Solomatic® II 70 System Box

gh →l	P	BOH	C	A
1490	188	190		
2020	218	220		
2760	258	260	121	55.5
3450	298	300		
4845		300 ¹		

Solomatic® II 80 System Box

gh →l	P	BOH	C	A
1740	188	190		
2320	218	220		
3210	258	260	141	69
4000	298	300		
4845		300 ¹		

¹ Slat package not covered (package projection)

* + possible addition for protruding weatherboard or doorknobs.

i Header dimensions are approximate values which may exhibit **negative or positive deviations** depending on the technical circumstances. **A dimensional tolerance of ±5 mm** is observed for the header height.

Slat profiles

Solomatic® II 70 System

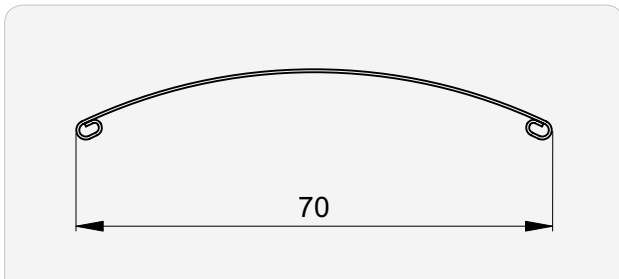

Solomatic® II 80 System

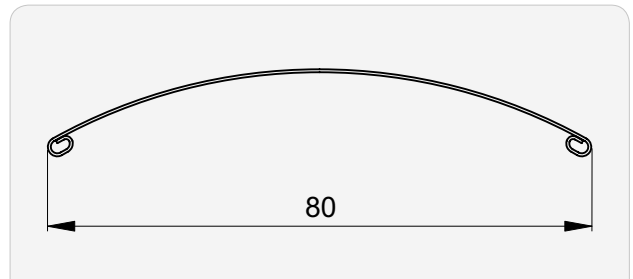

End rails

Solomatic® II 70 System

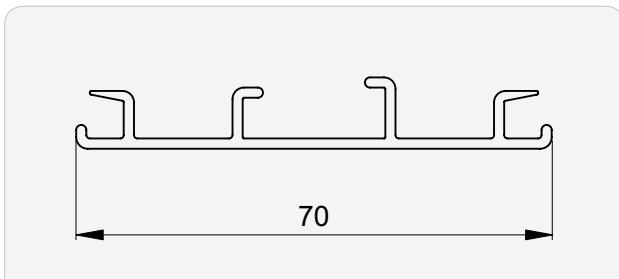

Solomatic® II 80 System

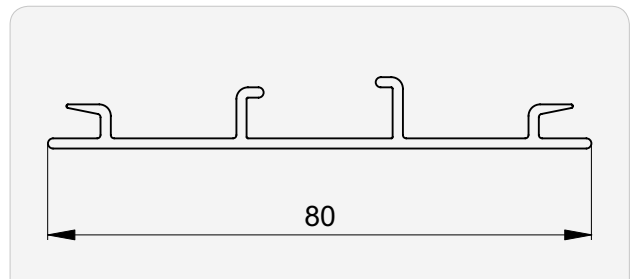

Beginning distance | Slot spacing

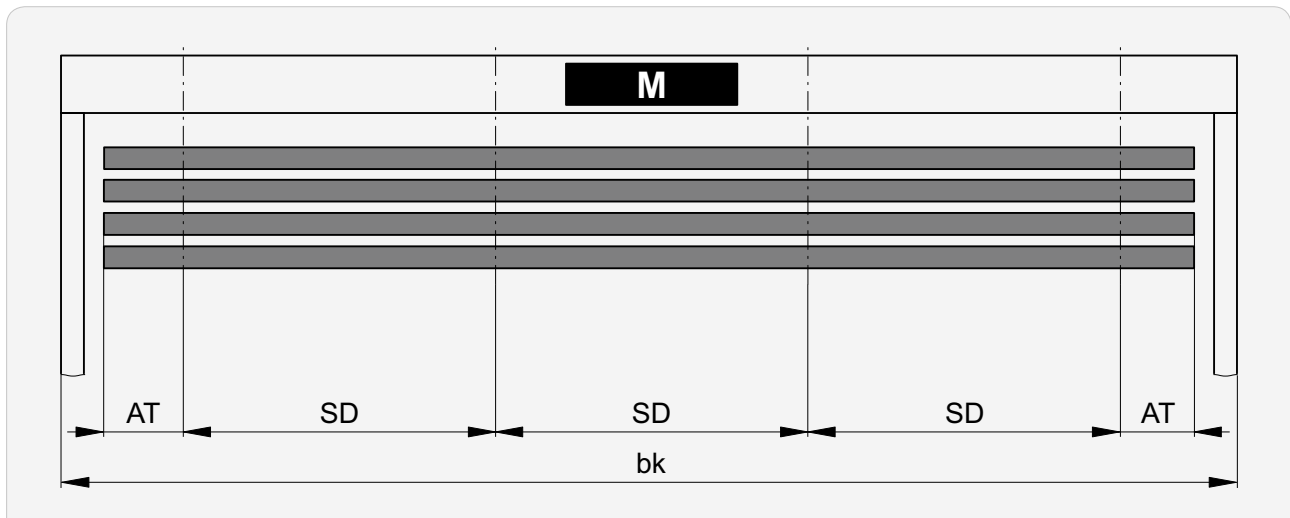

bk	AT min.	SD min.	SD max.
≤610	50		
611...1250	100	250*	1000*
>1250	200		

* Standard slot spacing machine fabrication

Deviations from the standard are possible when:

Deviation	Correction
Support loading too high	AS
Slot spacing < 250	AT + AS
With motor	AT + AS

Orientation of cable outlet

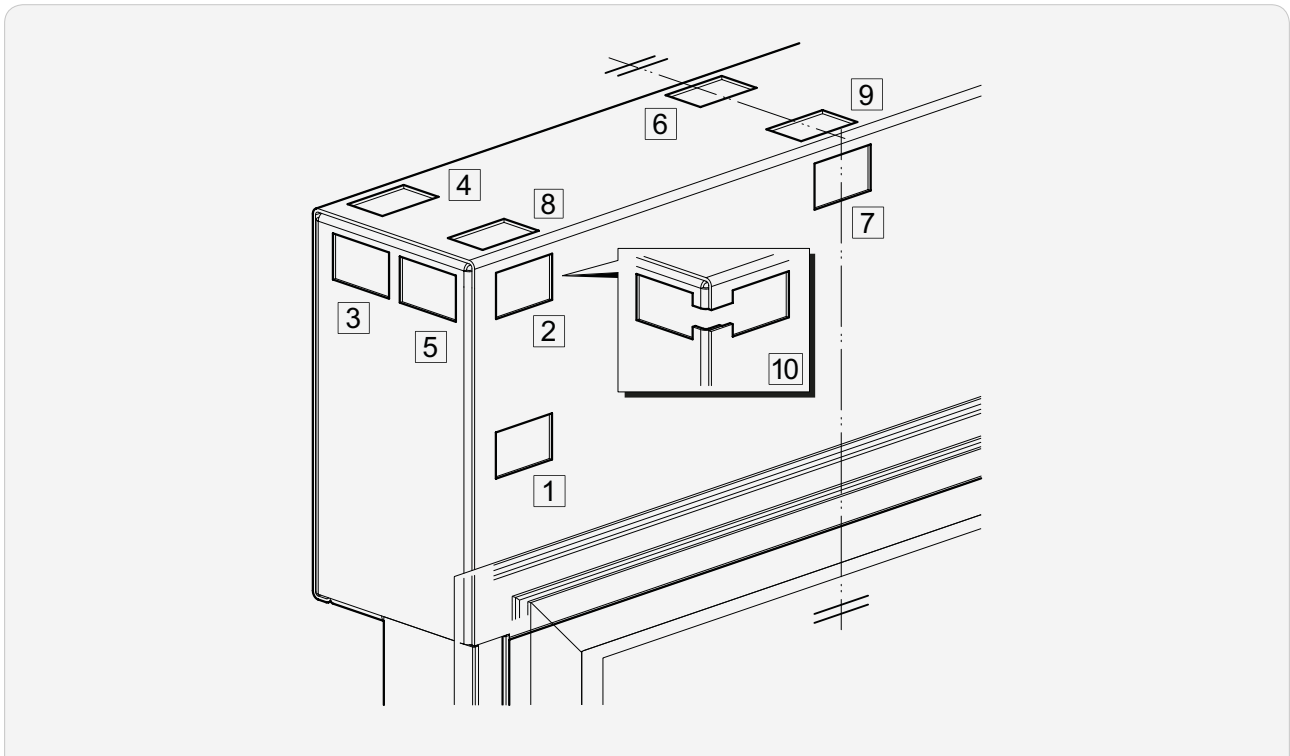

Solomatic® II 70 System

Position	Cable outlet									
	1	2	3	4	5	6	7	8	9	10
left	01L	02L*	03L	04L	05L	–	–	08L*	–	10L
centre	–	–	–	–	–	06M	07M*	–	09M*	–
right	01R	02R*	03R	04R	05R	–	–	08R*	–	10R

Solomatic® II 80 System

Position	Cable outlet									
	1	2	3	4	5	6	7	8	9	10
left	01L	02L*	03L	04L	05L	–	–	08L	–	10L
centre	–	–	–	–	–	06M	07M*	–	09M	–
right	01R	02R*	03R	04R	05R	–	–	08R	–	10R

! *The plug cannot be passed through when assembled!

Guide rails

Type P | Solomatic® II 70/80 System Profil

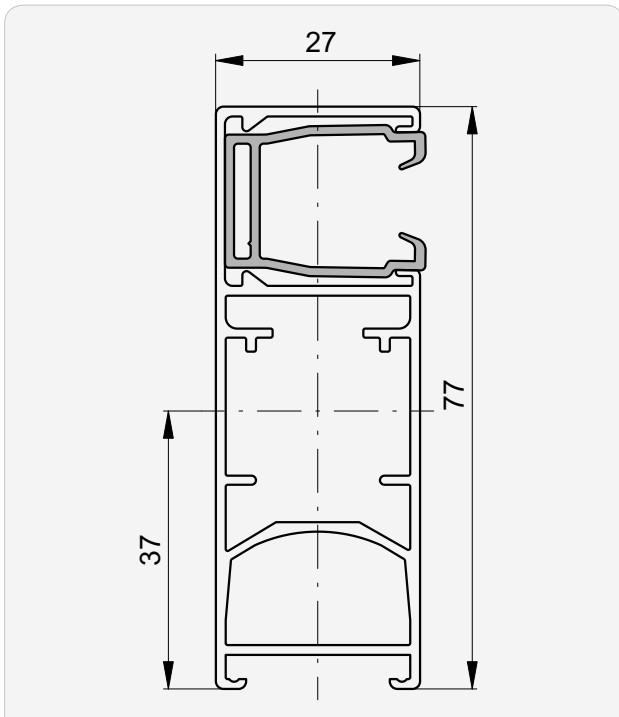

Type K | Solomatic® II 70 System Box

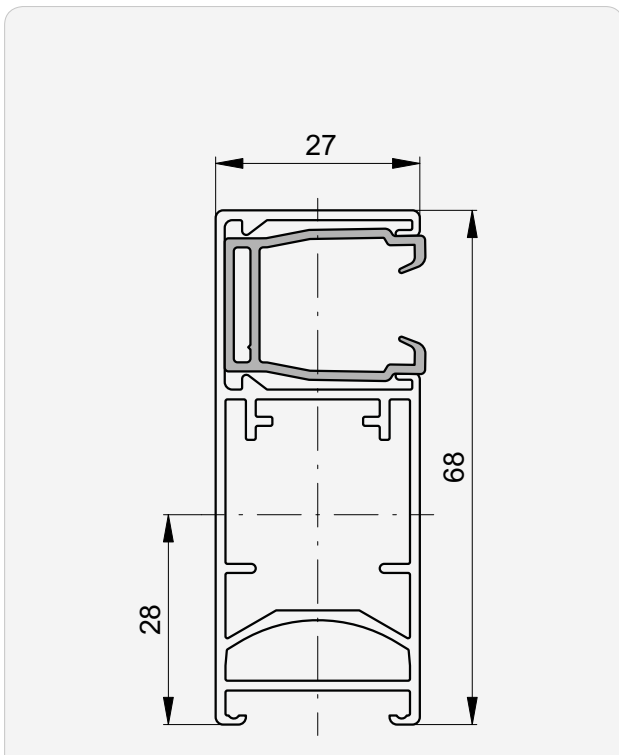

Type B | Solomatic® II 80 System Box

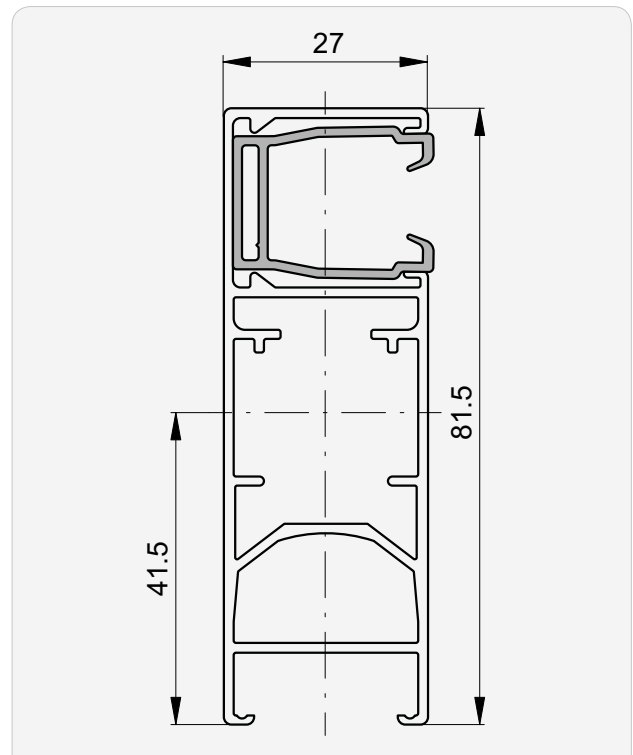

➤ Fastening points	323 327
➤ Guide extension and facet	321

➤ Guide rail fastenings	320
-------------------------------	-----

Sections | Details

Horizontal section: Solomatic® II 70 System Profil

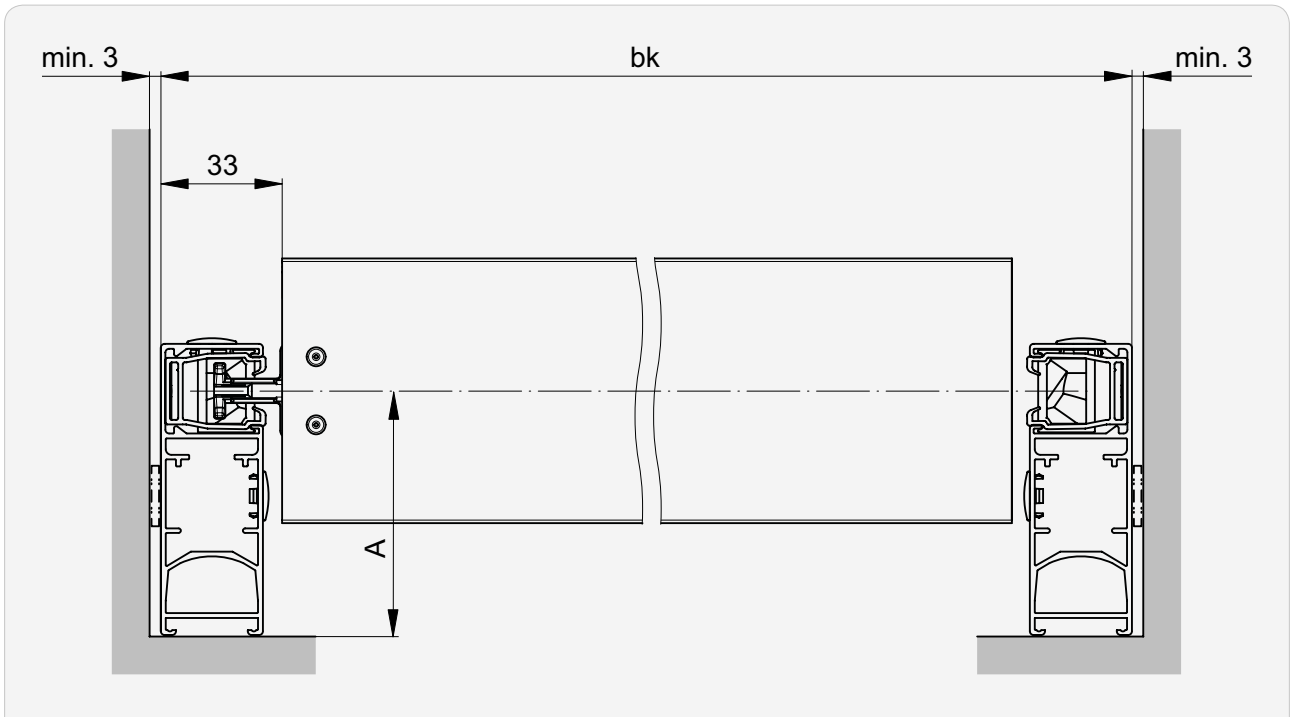

Horizontal section: Solomatic® II 80 System Profil

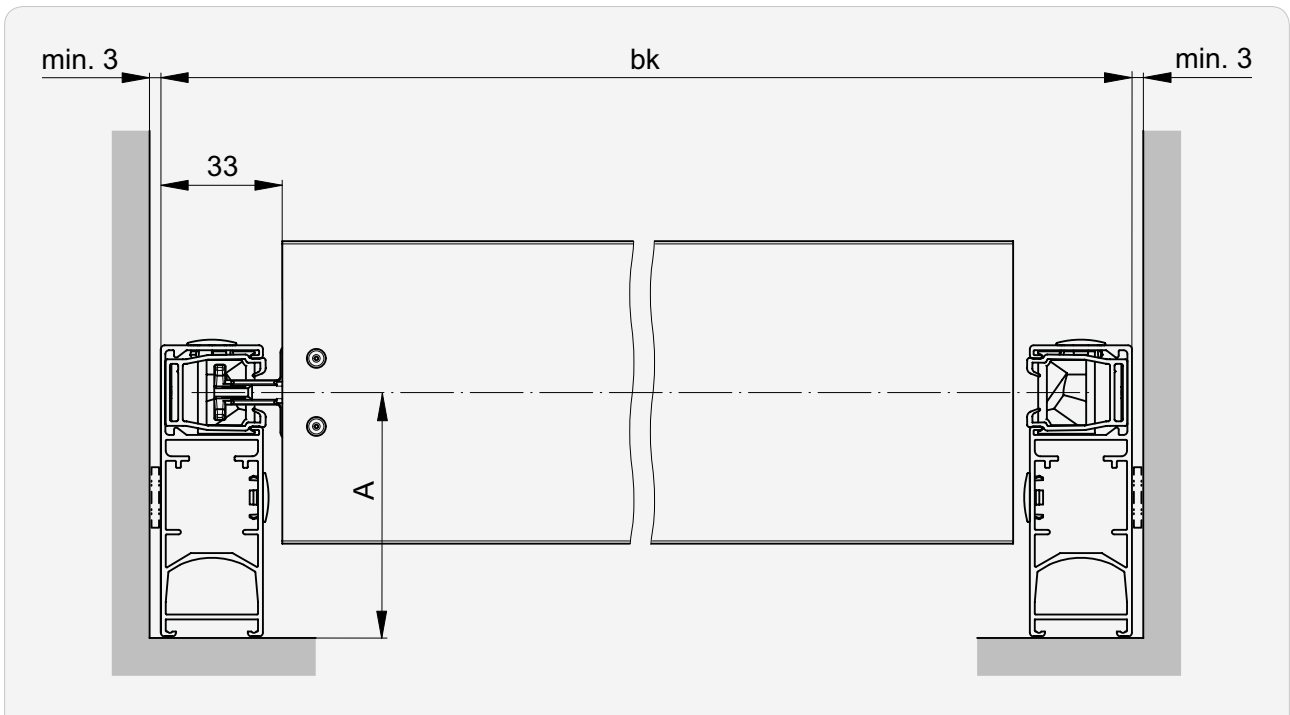

➡ Value for A 307

►► Sections | Details

Horizontal section: Solomatic® II 70 System Box

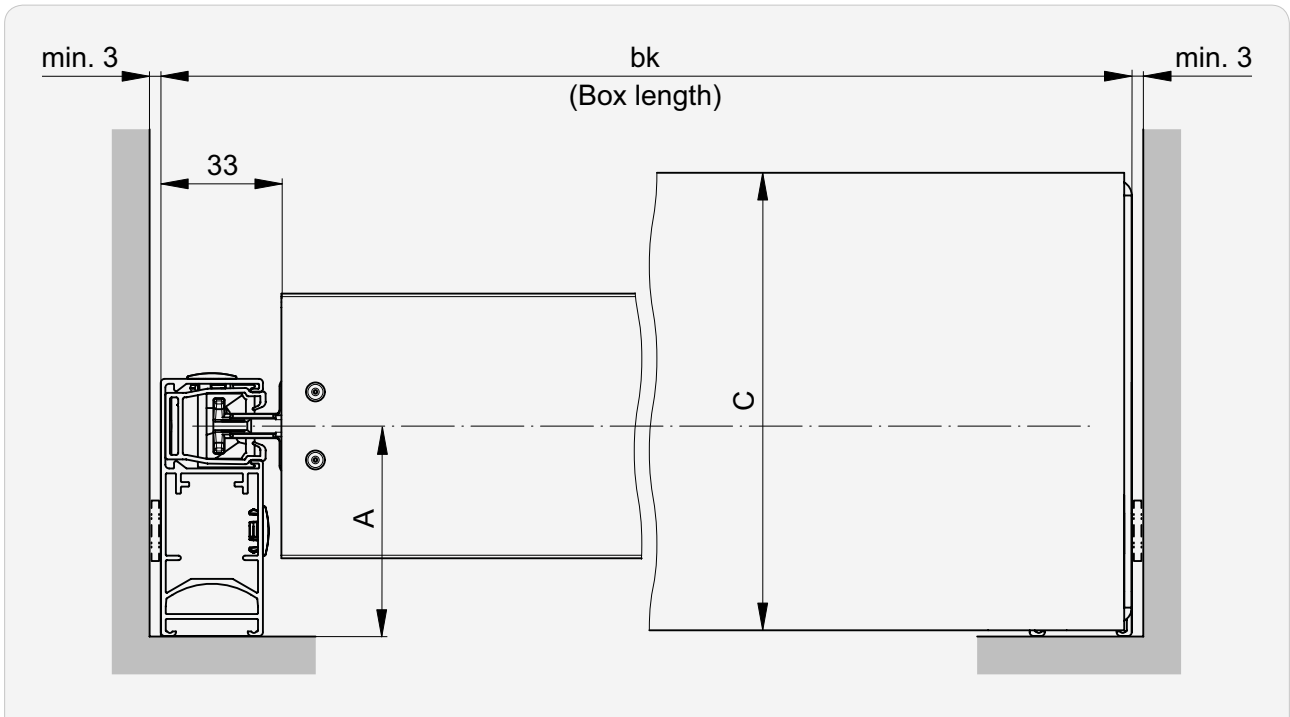

Horizontal section: Solomatic® II 80 System Box

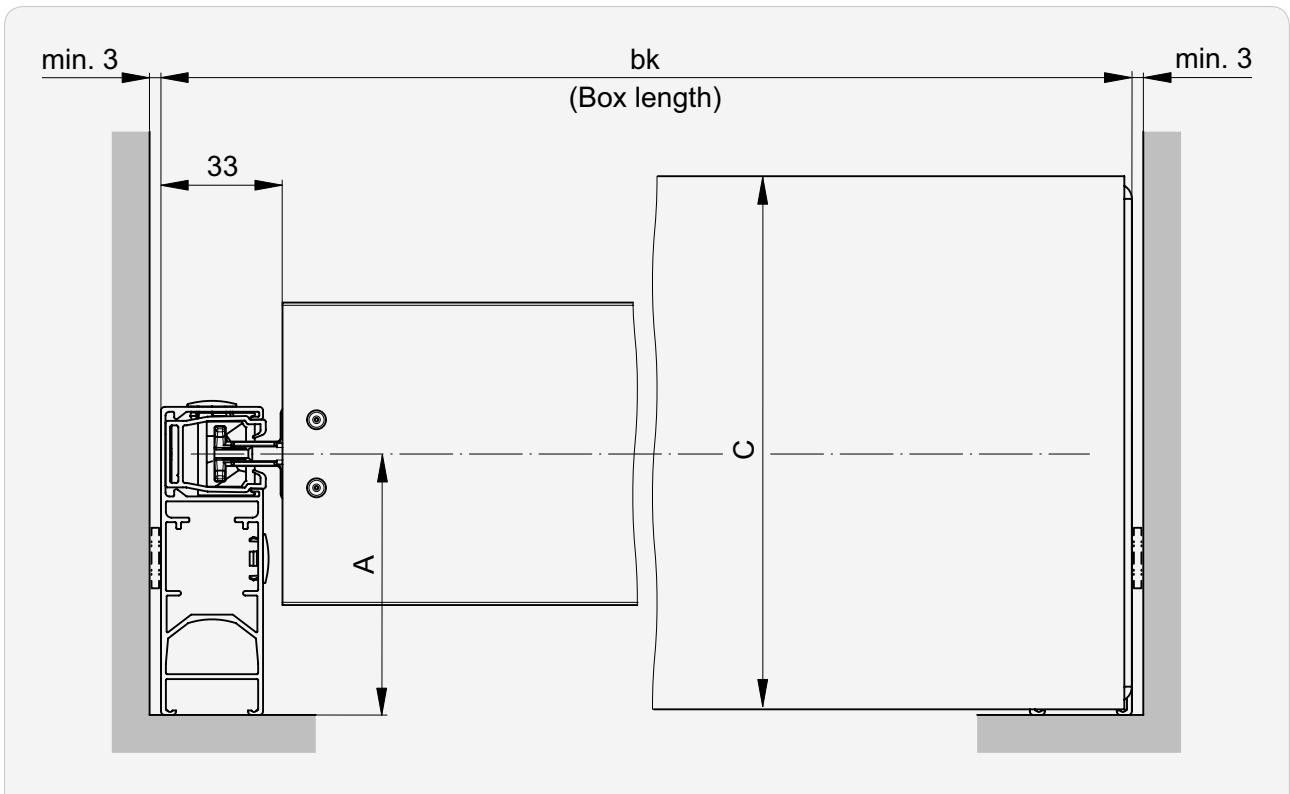

➔ Values for **A** and **C** 307

Vertical connections | Standard motor position

Number of bearings

Solomatic® II 70 System

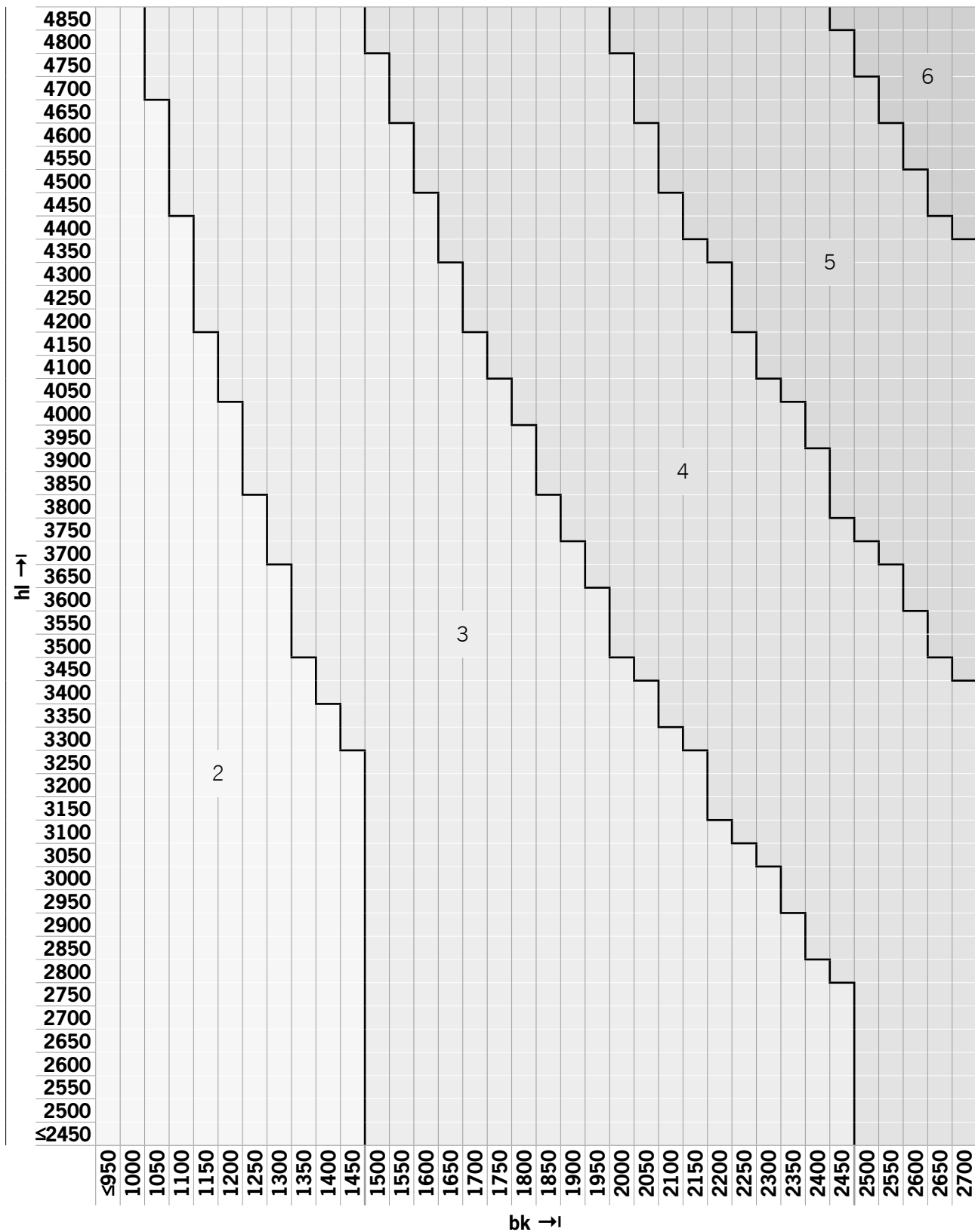

►► Vertical connections | Standard motor position

Number of bearings

Solomatic® II 70 System

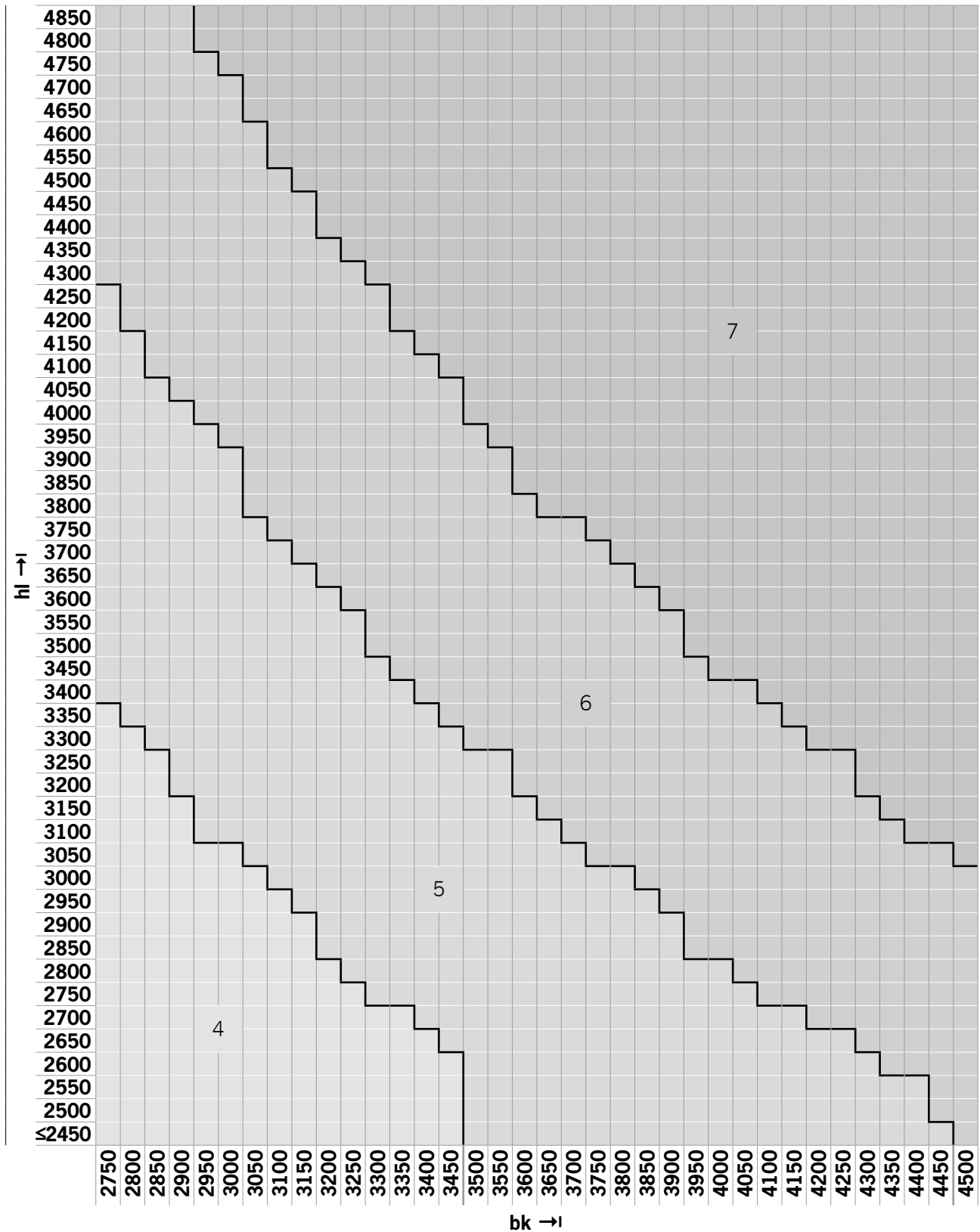

►► Vertical connections | Standard motor position

Number of bearings

Solomatic® II 80 System

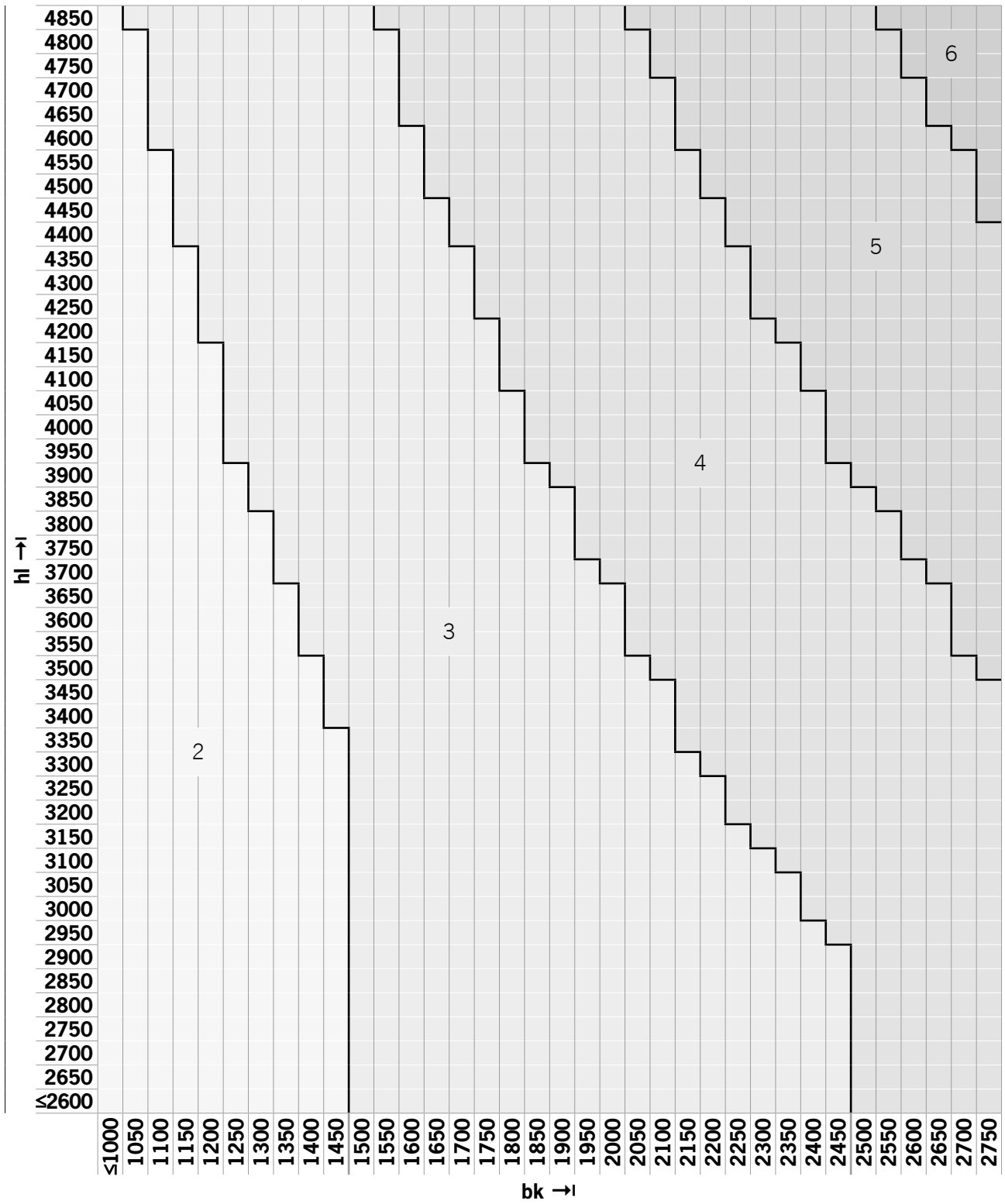

►► Vertical connections | Standard motor position



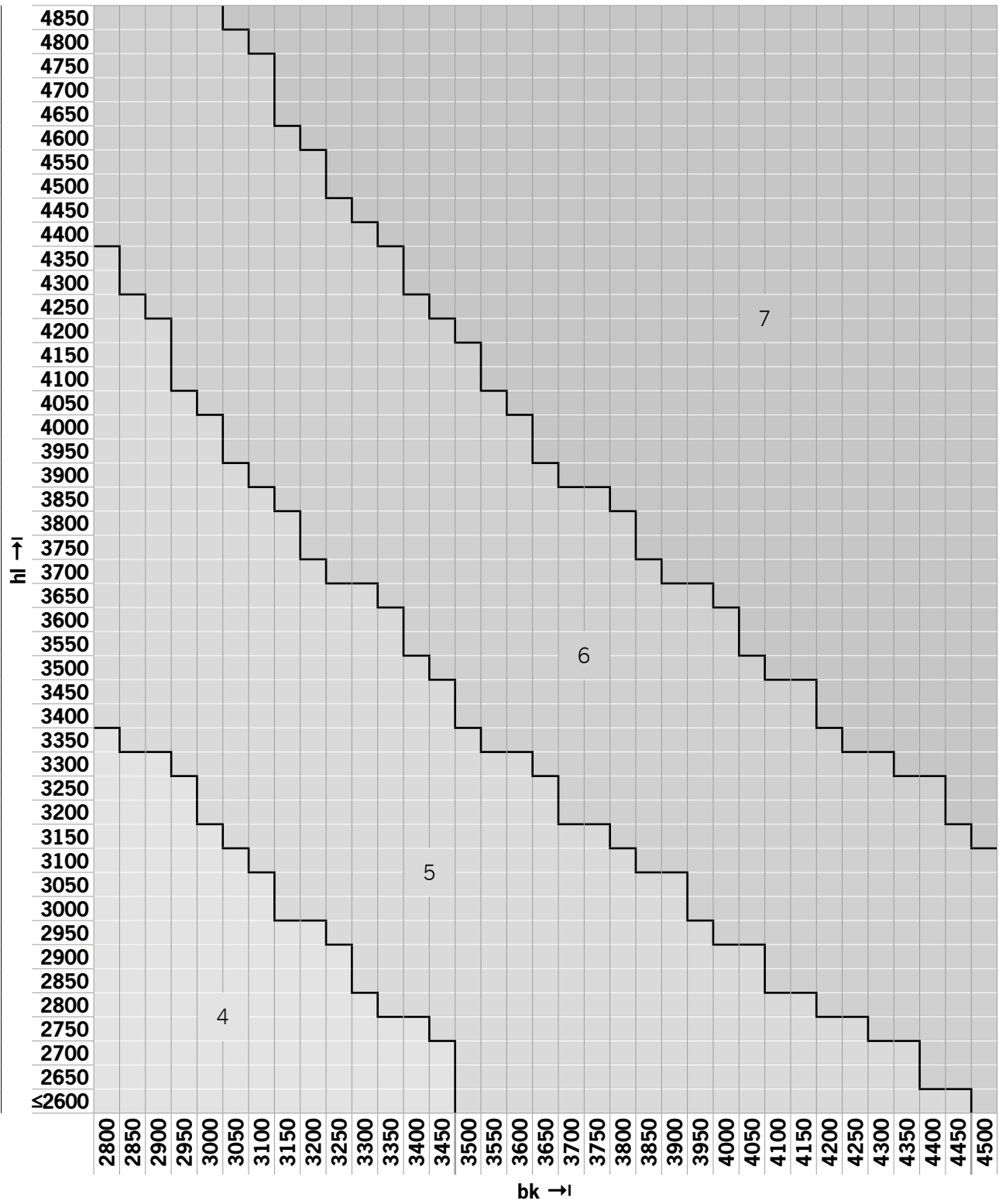

Number of bearings

Solomatic® II 80 System

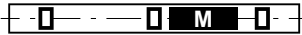

▶▶ Vertical connections | Standard motor position

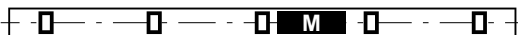
Standard motor position

Number of bearings	Standard motor position
2	
3	
4	
5	
6	
7	

- Bearing
- M Standard motor position

Guide rail installation (principle)

Guides attached (to soffit) | Type A

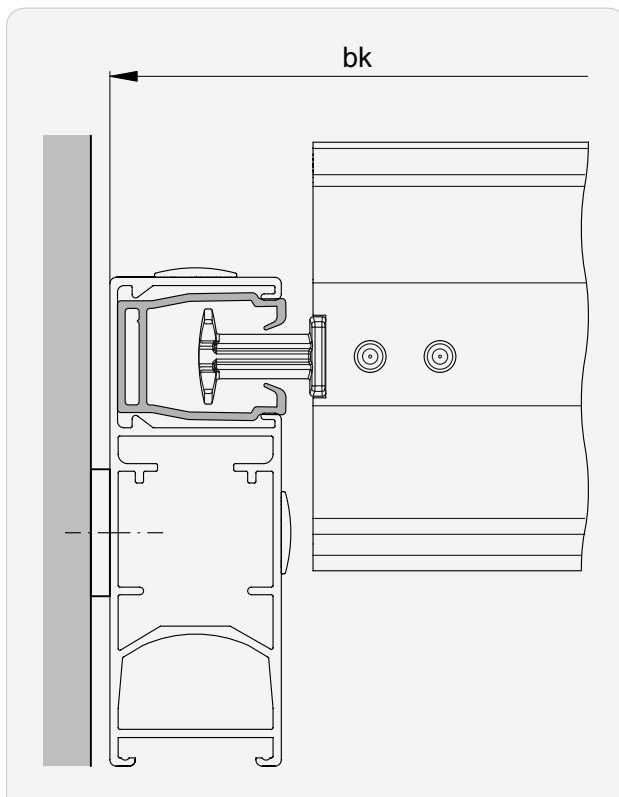

i Observe possible guide rail spacer for **bk**.
Standard: 3 mm

Guide rail fastenings (principle)

Overview

														Type
A	B	Bd	C	Cd	E	F	G	H	Kv	M	T	Tv	V	Wv
●	-	-	-	-	-	-	●	-	-	-	-	-	-	-

● applicable without restrictions

A Soffit installation

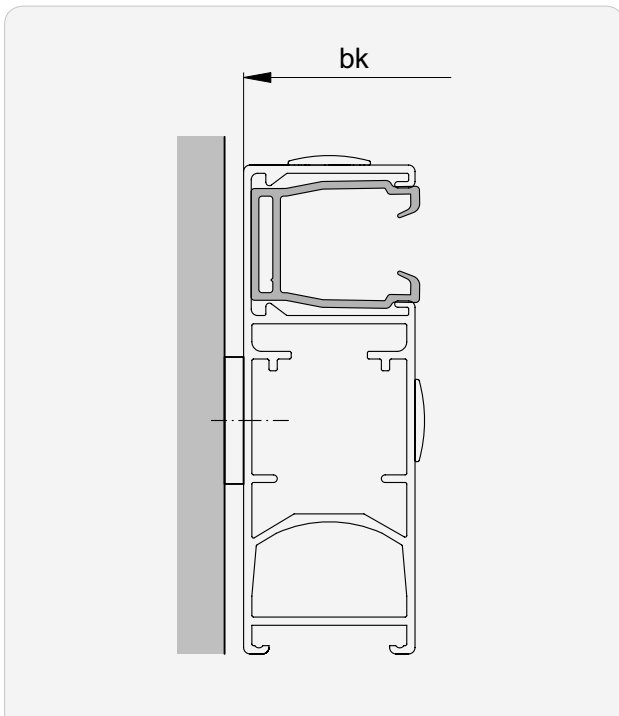

G Facade installation

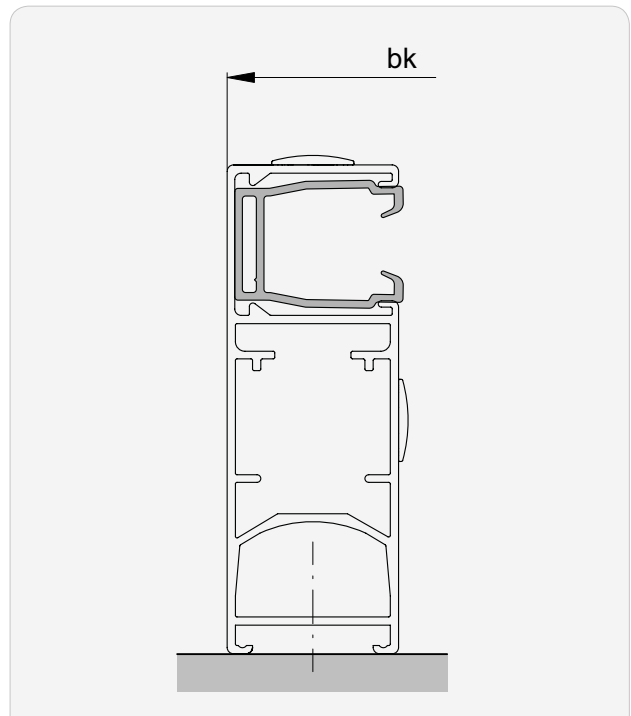

i Observe possible guide rail spacer for **bk**.
Standard: 3 mm

Guide extension and facet

Extension

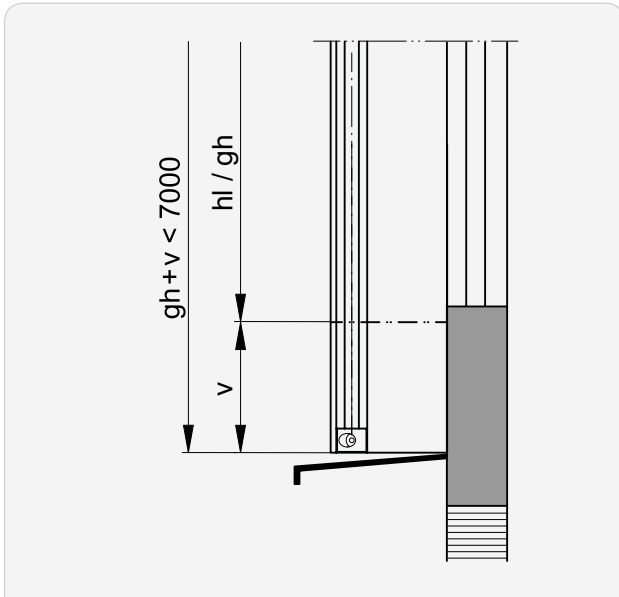

v
-20... 1000

Facet

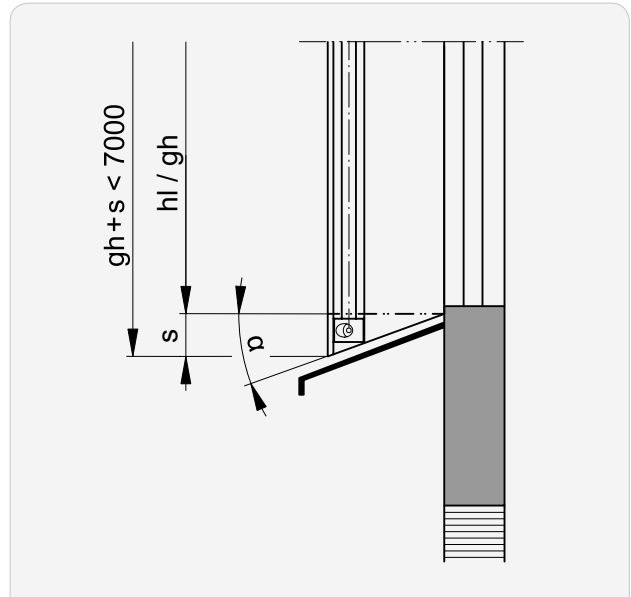

α
5... 50°

Extension and facet

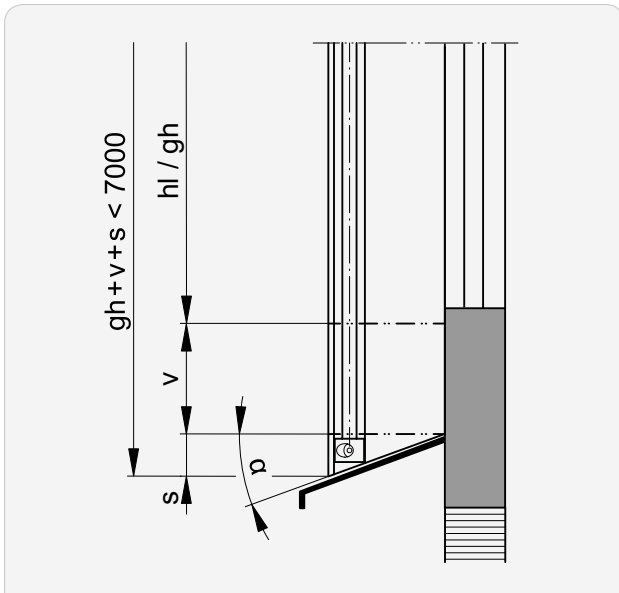

v
0... 1000

α
5... 50°

➔ Value for **s**..... 322

Angling at the guides

Type P | Solomatic® II System Profil

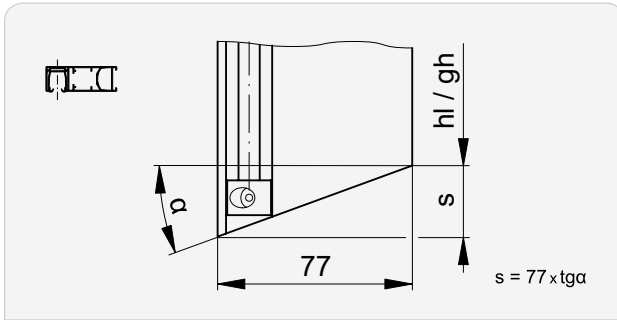

α	s	α	s	α	s	α	s	α	s
5	7	15	21	25	36	35	54	45	77
6	8	16	22	26	38	36	56	46	80
7	9	17	24	27	39	37	58	47	83
8	11	18	25	28	41	38	60	48	86
9	12	19	27	29	43	39	62	49	89
10	14	20	28	30	44	40	65	50	92
11	15	21	30	31	46	41	67		
12	16	22	31	32	48	42	69		
13	18	23	33	33	50	43	72		
14	19	24	34	34	52	44	74		

Type K | Solomatic® II 70 System Box

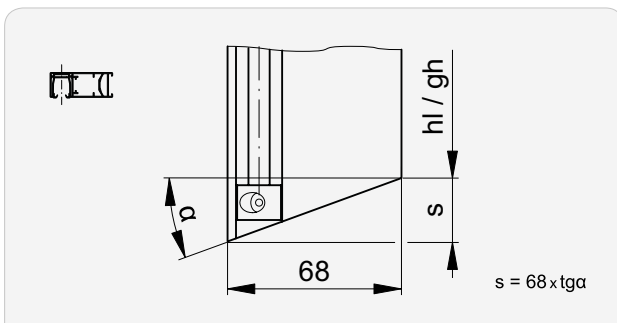

α	s	α	s	α	s	α	s	α	s
5	6	15	18	25	32	35	48	45	68
6	7	16	19	26	33	36	49	46	70
7	8	17	21	27	35	37	51	47	73
8	10	18	22	28	36	38	53	48	76
9	11	19	23	29	38	39	55	49	78
10	12	20	25	30	39	40	57	50	81
11	13	21	26	31	41	41	59		
12	14	22	27	32	42	42	61		
13	16	23	29	33	44	43	63		
14	17	24	30	34	46	44	66		

Type B | Solomatic® II 80 System Box

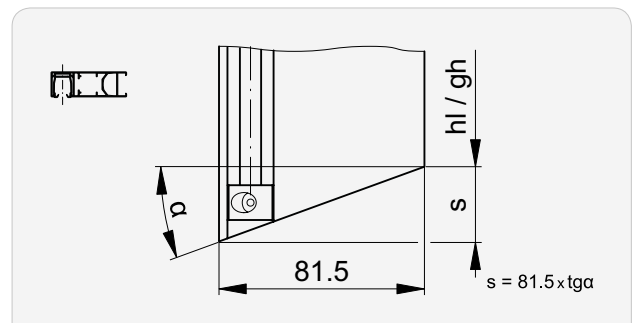

α	s	α	s	α	s	α	s	α	s
5	7	15	22	25	38	35	57	45	82
6	9	16	23	26	40	36	59	46	84
7	10	17	25	27	42	37	61	47	87
8	11	18	26	28	43	38	64	48	91
9	13	19	28	29	45	39	66	49	94
10	14	20	30	30	47	40	68	50	97
11	16	21	31	31	49	41	71		
12	17	22	33	32	51	42	73		
13	19	23	35	33	53	43	76		
14	20	24	36	34	55	44	79		

Fastening points Solomatic® II System Profil

Without extension

Z	AS
≤ 1500	2
1501 ... 2700	3
2701 ... 3900	4
3901 ... 5100	5
> 5100	6

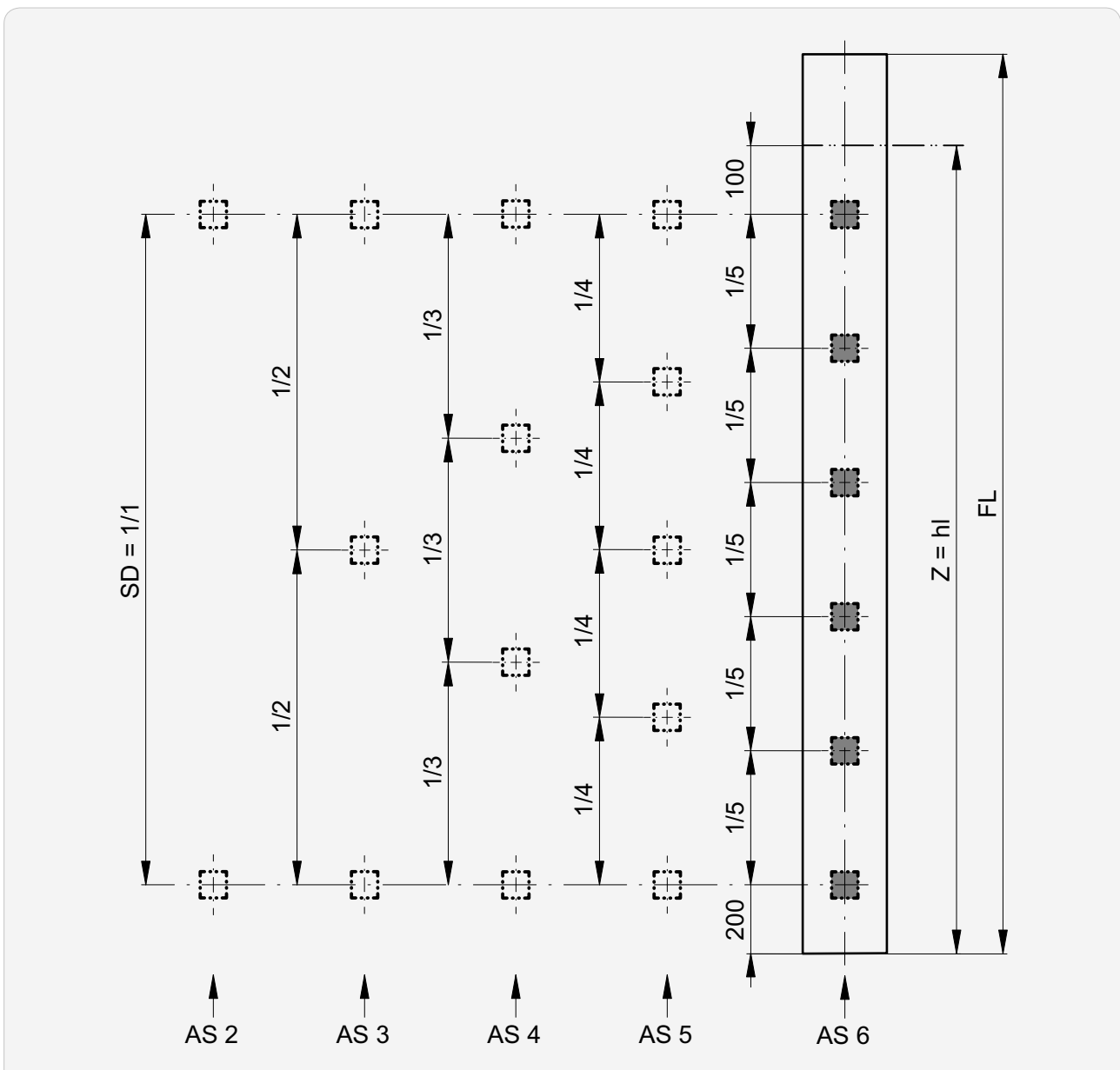

AS Number of slits

SD Slot spacing: max. 1200

[Guide rail fastenings](#) 320

►► Fastening points Solomatic® II System Profil

With guide rail extension

Z	AS
≤ 1500	2
1501 ... 2700	3
2701 ... 3900	4
3901 ... 5100	5
> 5100	6

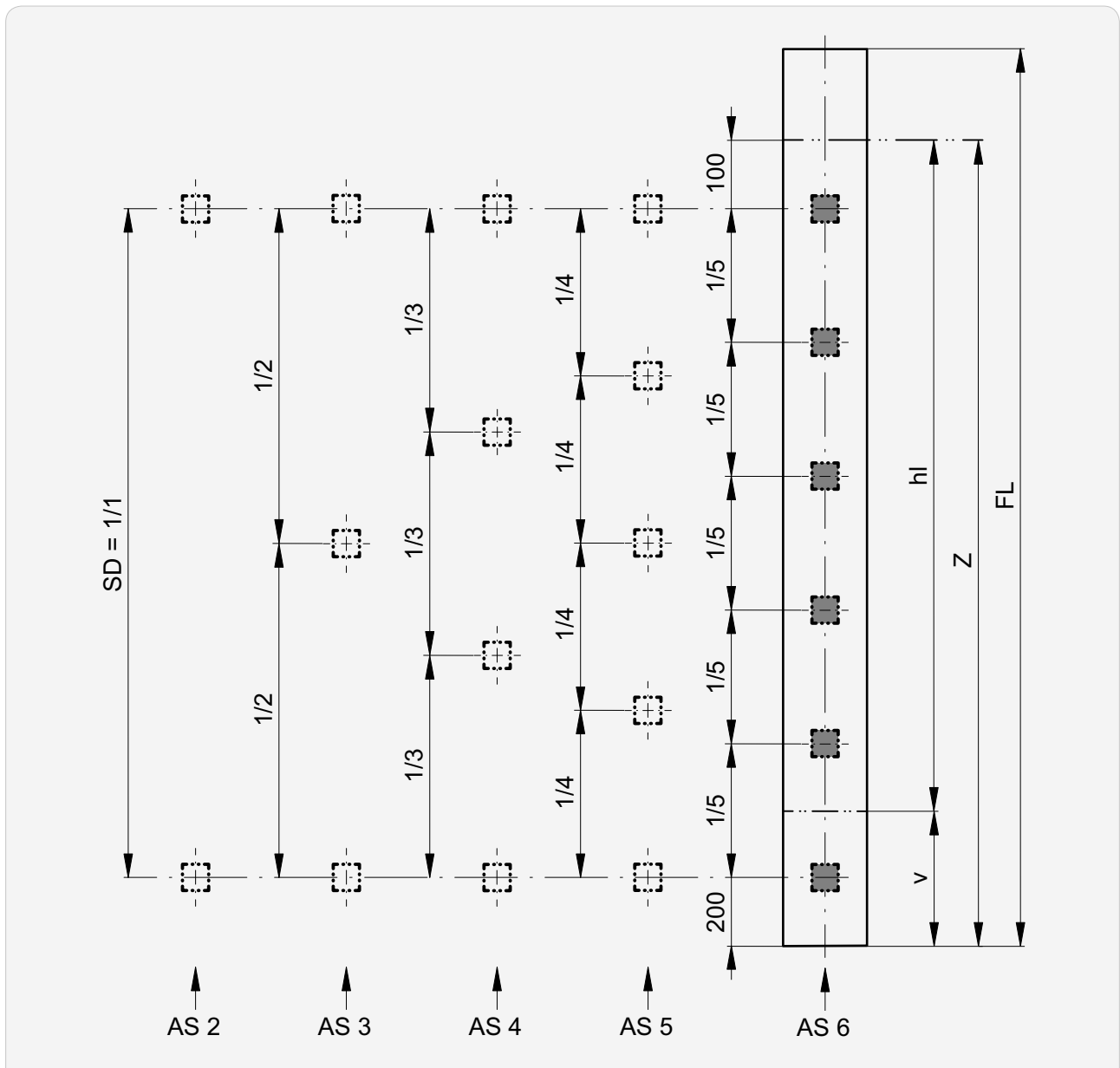

AS Number of slits
SD Slot spacing: max. 1200

v Guide rail extension: max. 1000

►► Fastening points Solomatic® II System Profil

With facet

Z	AS
≤ 1500	2
1501 ... 2700	3
2701 ... 3900	4
3901 ... 5100	5
> 5100	6

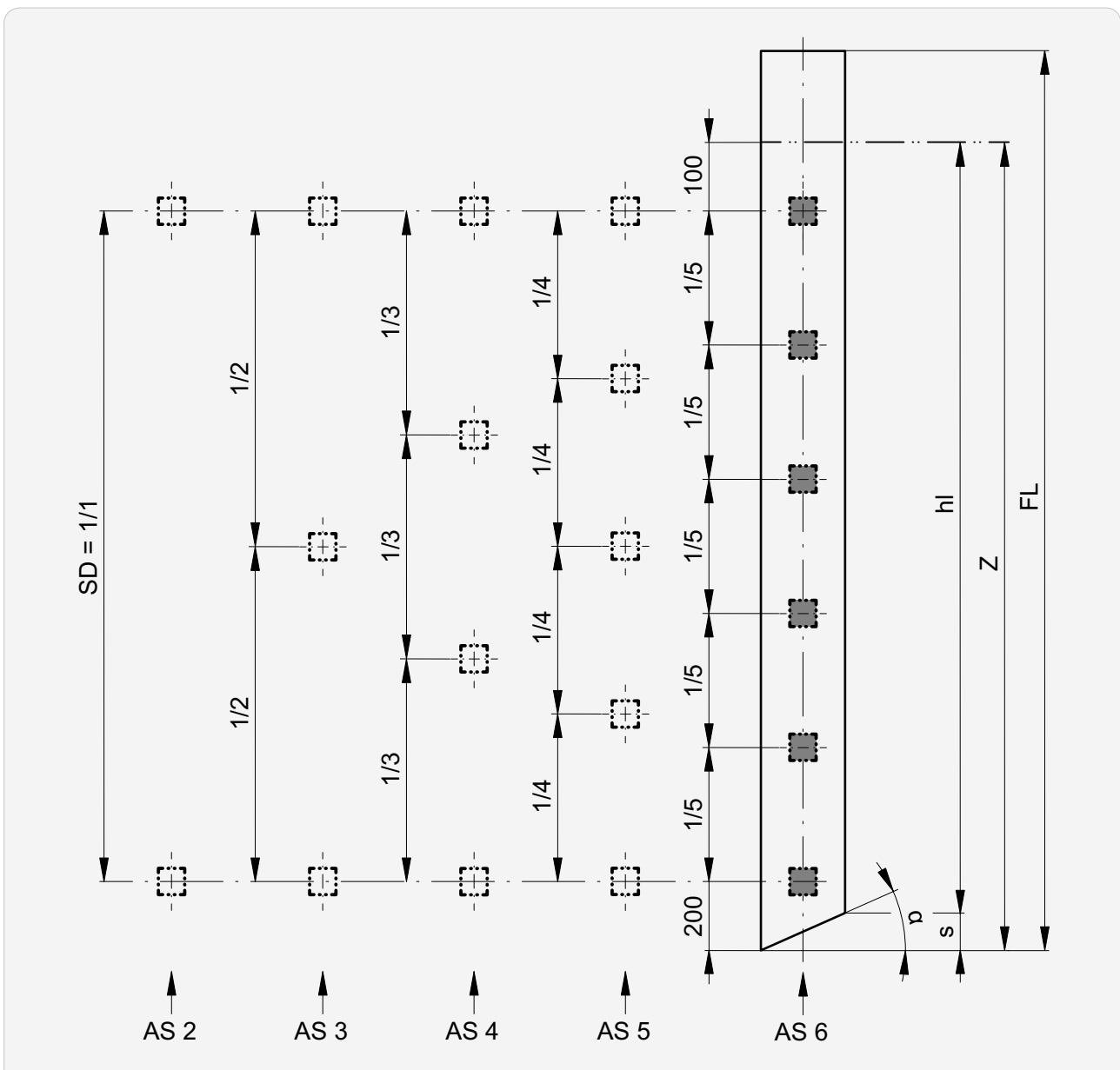

AS Number of slits

SD Slot spacing: max. 1200

s Faceting (guide rail width x tgα)

►► Fastening points Solomatic® II System Profil

With guide rail extension and facet

Z	AS
≤ 1500	2
1501 ... 2700	3
2701 ... 3900	4 </td
3901 ... 5100	5
> 5100	6

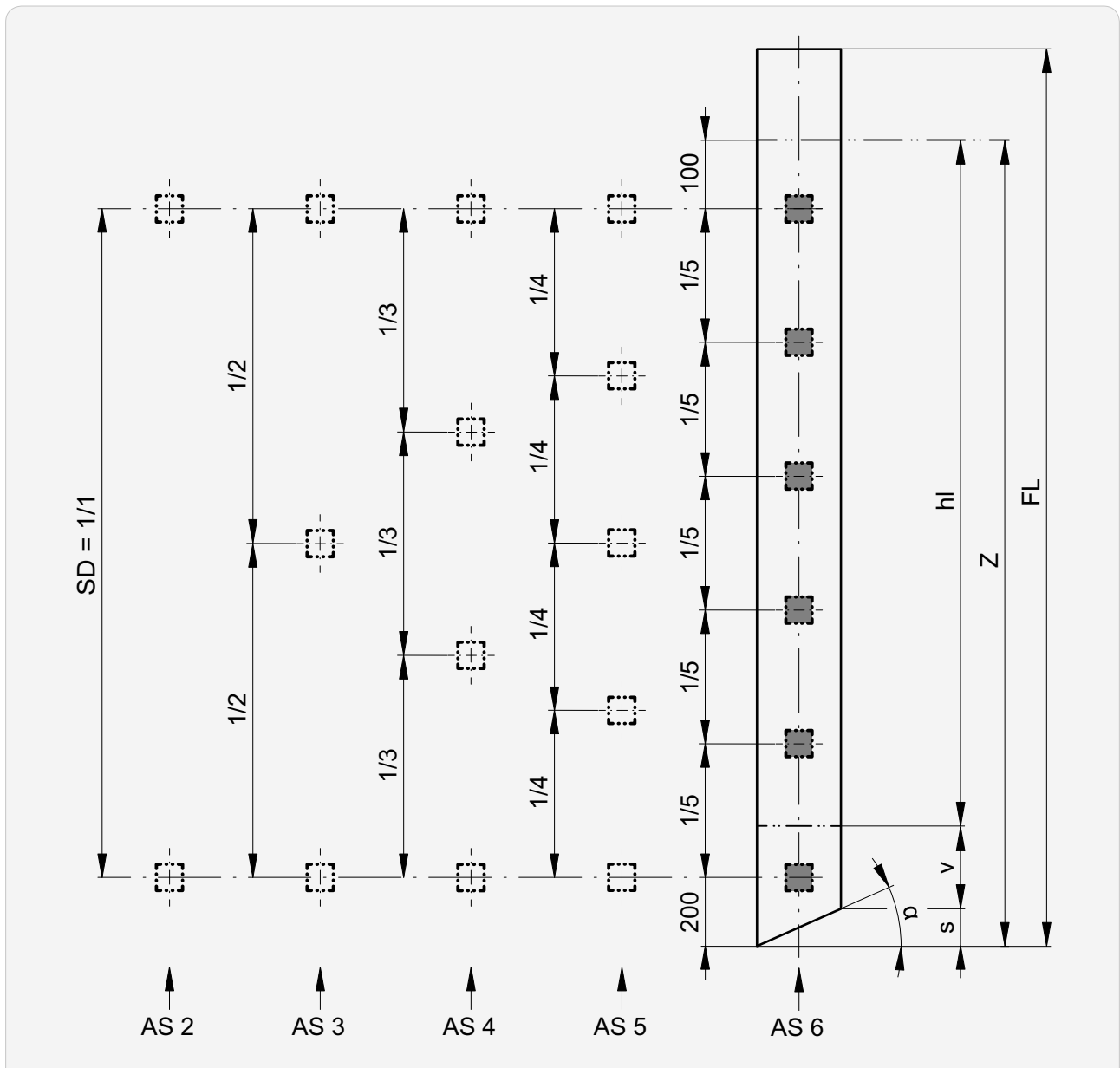

AS Number of slits

s Faceting (guide rail width x tgα)

SD Slot spacing: max. 1200

v Guide rail extension: max. 1000

Fastening points Solomatic® II System Box

Without extension

Z	AS
≤ 1450	2
1451 ... 2450	3
2451 ... 3450	4
> 3450	5

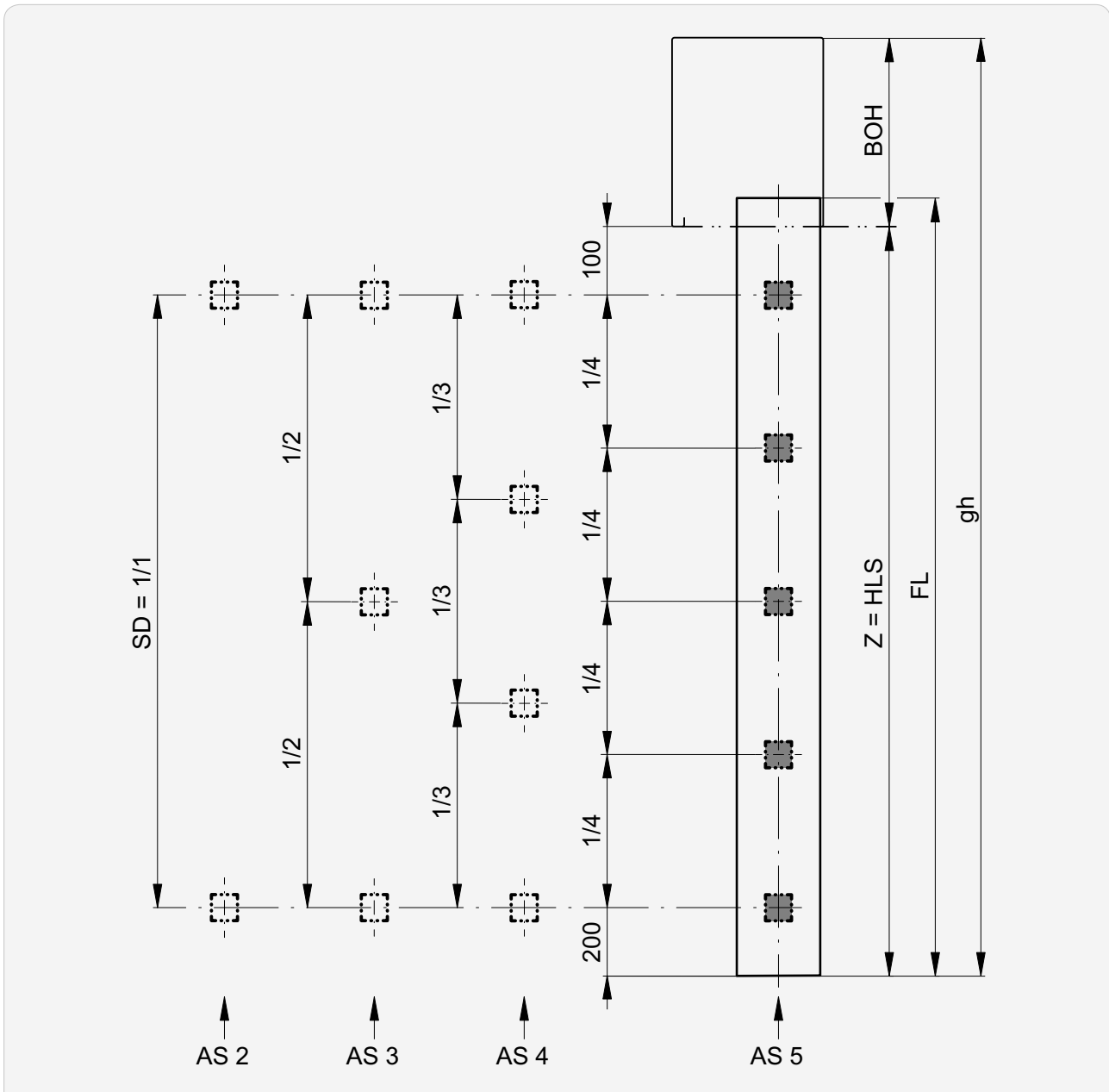

AS Number of slits

BOH Box height

SD Slot spacing: max. 1200

➔ Guide rail fastenings 320

►► Fastening points Solomatic® II System Profil

With guide rail extension

Z	AS
≤ 1450	2
1451 ... 2450	3
2451 ... 3450	4
> 3450	5

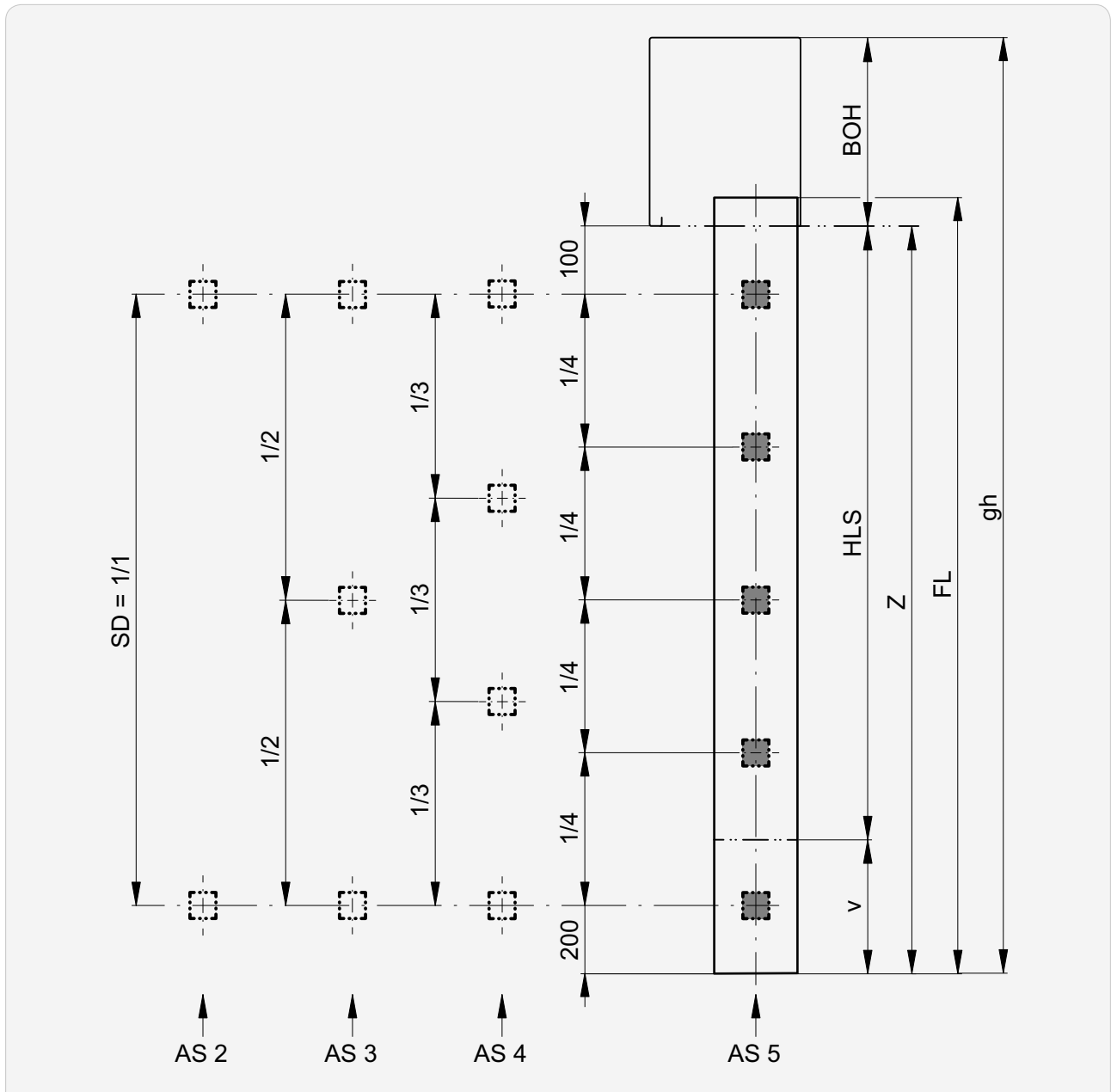

AS Number of slits

BOH Box height

SD Slot spacing: max. 1200

v Guide rail extension: max. 1000

►► Fastening points Solomatic® II System Profil

With facet

Z	AS
≤ 1450	2
1451 ... 2450	3
2451 ... 3450	4
> 3450	5

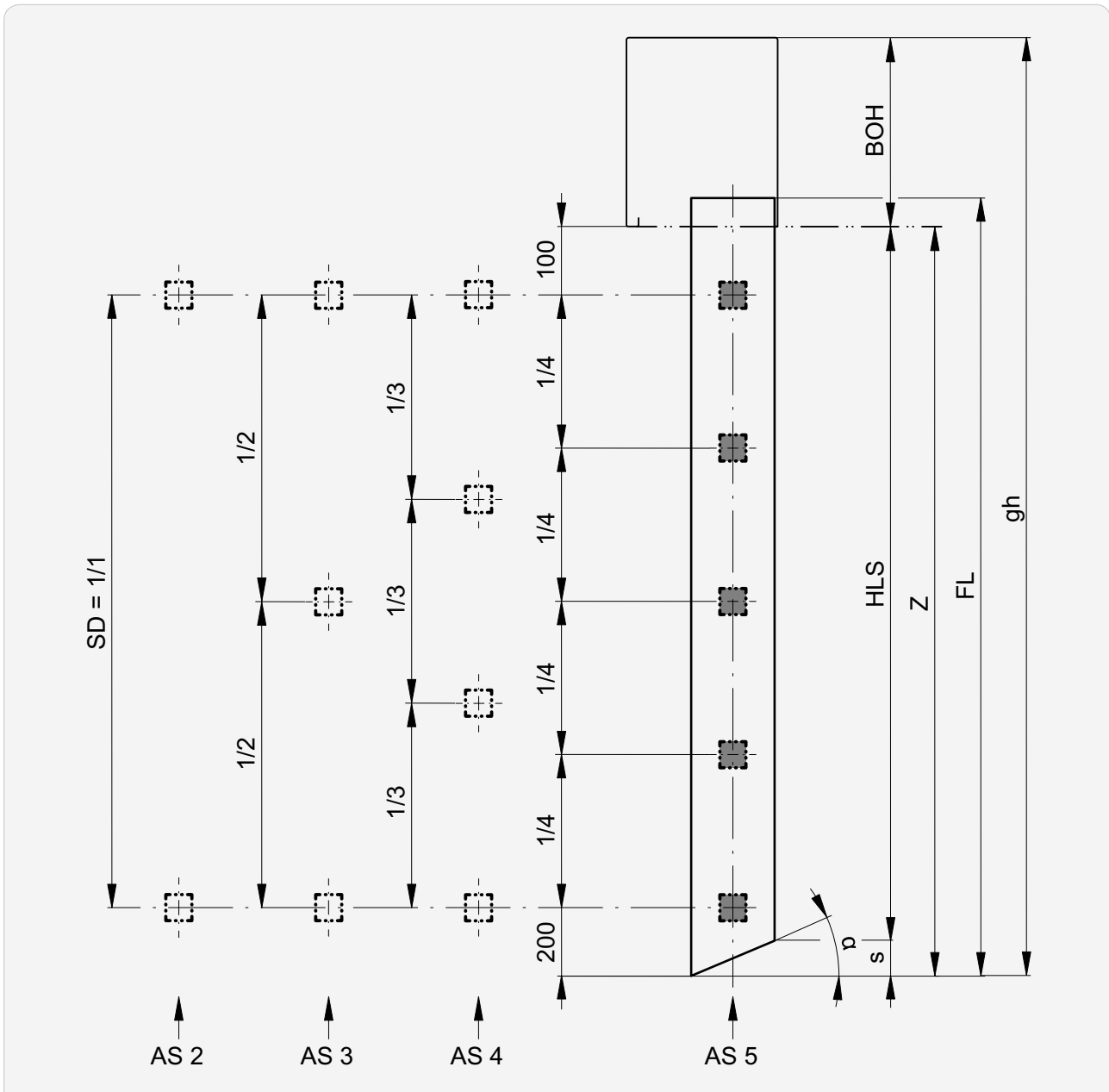

AS Number of slits

BOH Box height

s Faceting (guide rail width x tgα)

SD Slot spacing: max. 1200

►► Fastening points Solomatic® II System Profil

With guide rail extension and facet

Z	AS
≤ 1450	2
1451 ... 2450	3
2451 ... 3450	4
> 3450	5

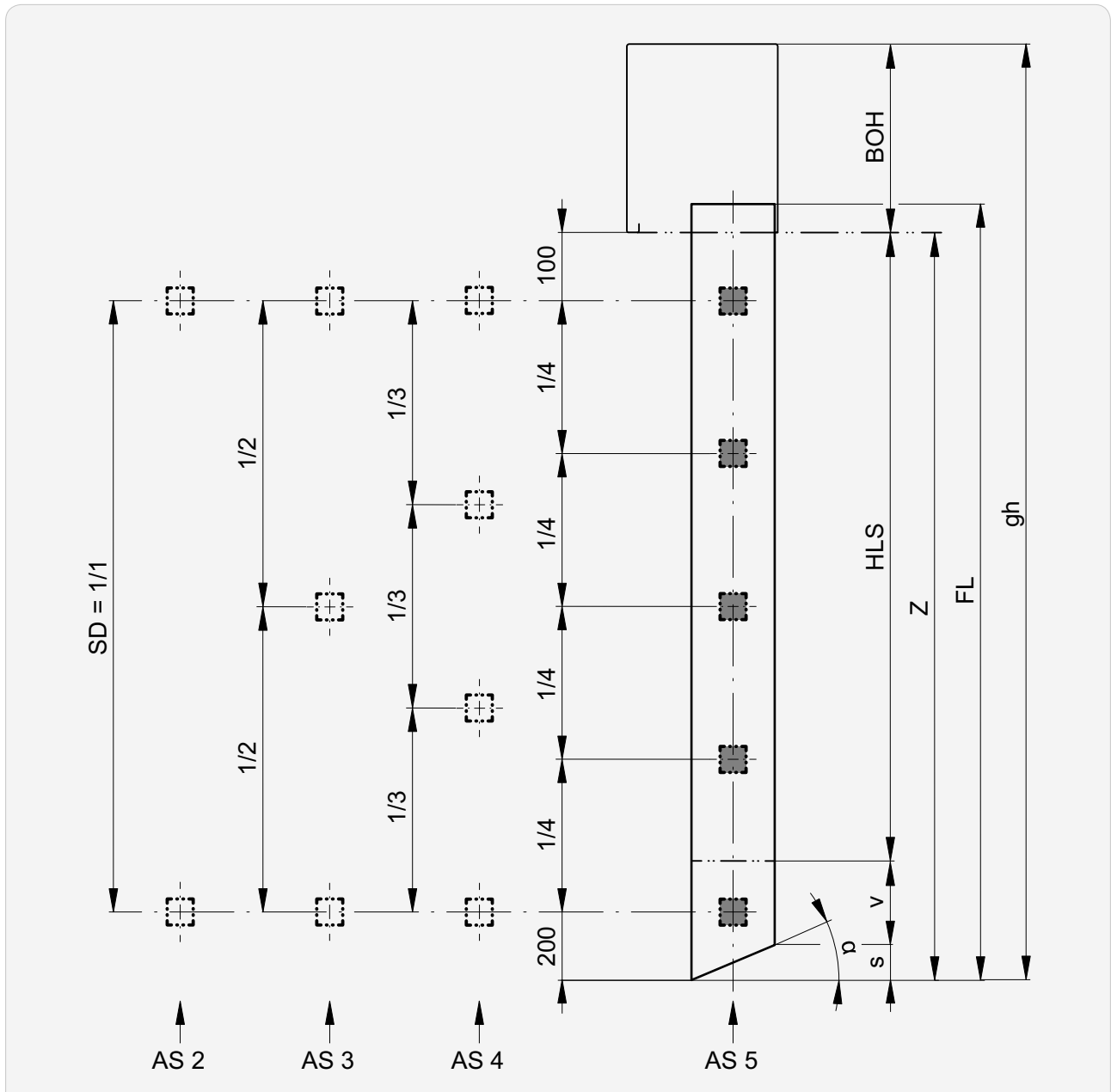

AS Number of slits

BOH Box height

s Faceting (guide rail width x tgα)

SD Slot spacing: max. 1200

v Guide rail extension: max. 1000

Technical data of motors

Performance characteristics

Type	Limit switch		M [Nm]	n [1/min.]	P [W]	I [A]
	Type	Number of				
Standard						
Elero						
ES...	06.01		6		110	0.50
	09.01	mechanical	9	26	170	0.75
EO...	20.01		20		190	1.05
ES...	06.51		6		110	0.50
	09.51	mechanical	9	26	170	0.75
EO...	20.51		20		190	1.05
Option						
Somfy						
	06.01		6		95	0.40
SH...	10.01	mechanical	10	24	110	0.65
	18.01		18		155	1.00
SW...	06.01		6		95	0.40
SI...	10.01	electronic	10	24	110	0.65
SR...	18.01		18		155	1.00
Elero Comfort						
	06.01		6		115	0.50
ECM...	09.01	electronic	9	26	156	0.68
	06.51		6		115	0.50
	09.51		9		156	0.68
	06.01		6		115	0.50
ECB...	09.01	electronic	9	26	156	0.68
	06.51		6		115	0.50
	09.51		9		156	0.68
Geiger AIR						
	06.01		6		93	0.40
GA...	06.10	electronic	10	26	135	0.60
	06.20		20		190	0.85

I Current consumption

M Torque

n Rotational speed

P Power consumption

Annex

Definitions of dimensions	334
Installation base	337

Definitions of dimensions

i Dimensions should always be viewed **from inside to outside**.
 Unspecified dimensions are **defined by the products**.
 Situations designed with **uniform guide profiles**.

bk

For rail guide

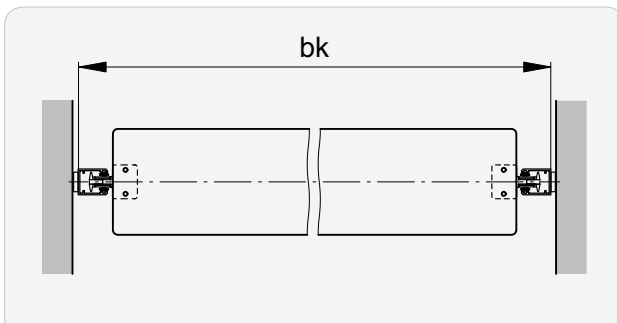

For cable guide

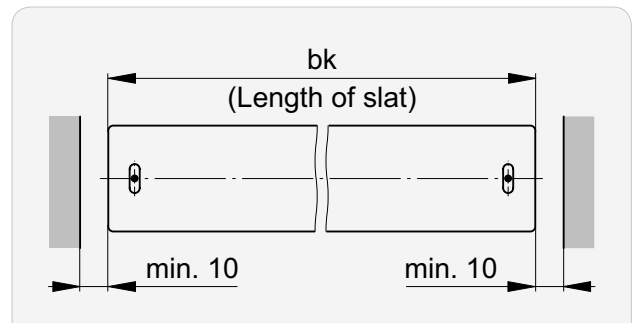

System width (Connected Systems)

For rail guide

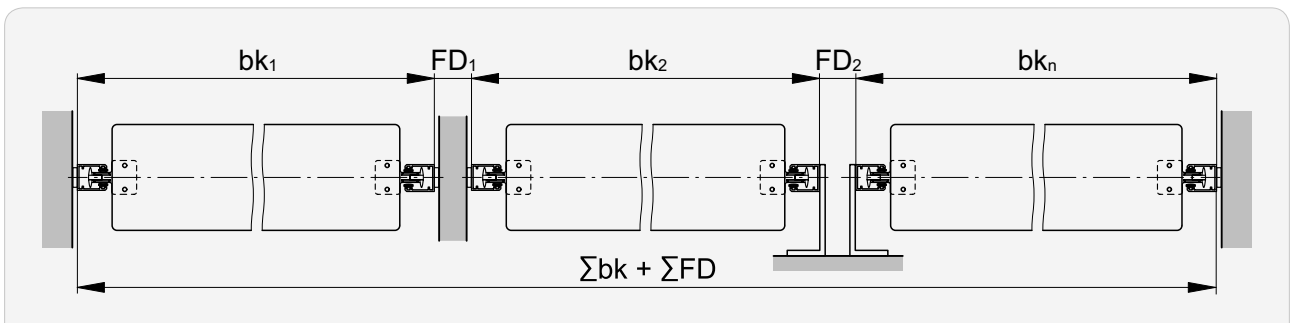

For cable guide

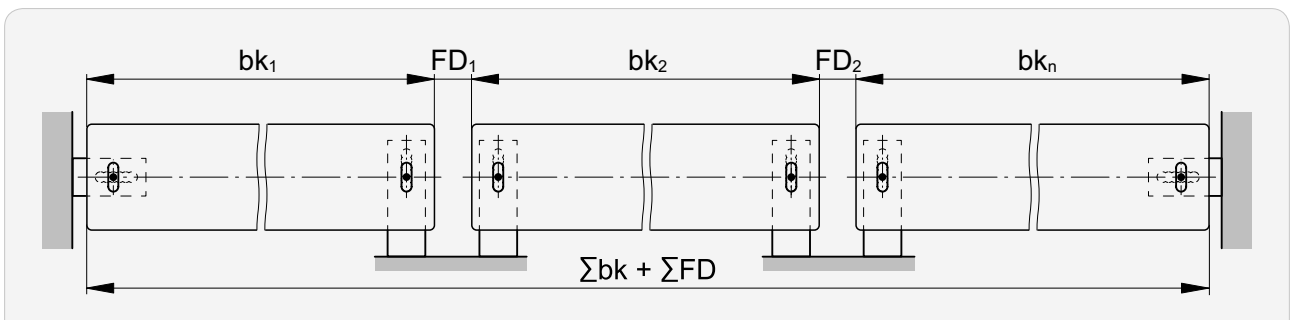

bk Construction width

FD Distance between guides

►► Definitions of dimensions

hl, hs, gh, p

For rail guide

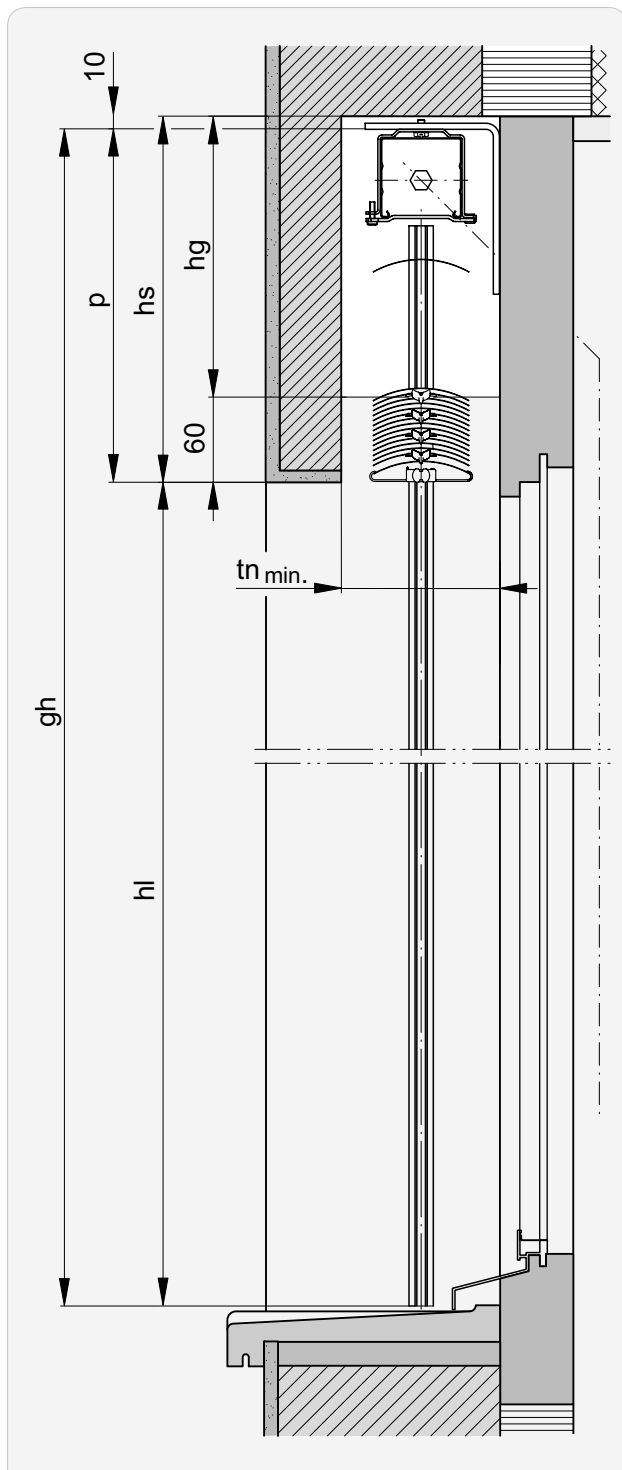

hl, gh at bottom: Bottom edge of guide rail

- gh** Overall height (**hl + p**)
- hg** Height of gearbox recess
- hl** Finished clear height

For cable guide

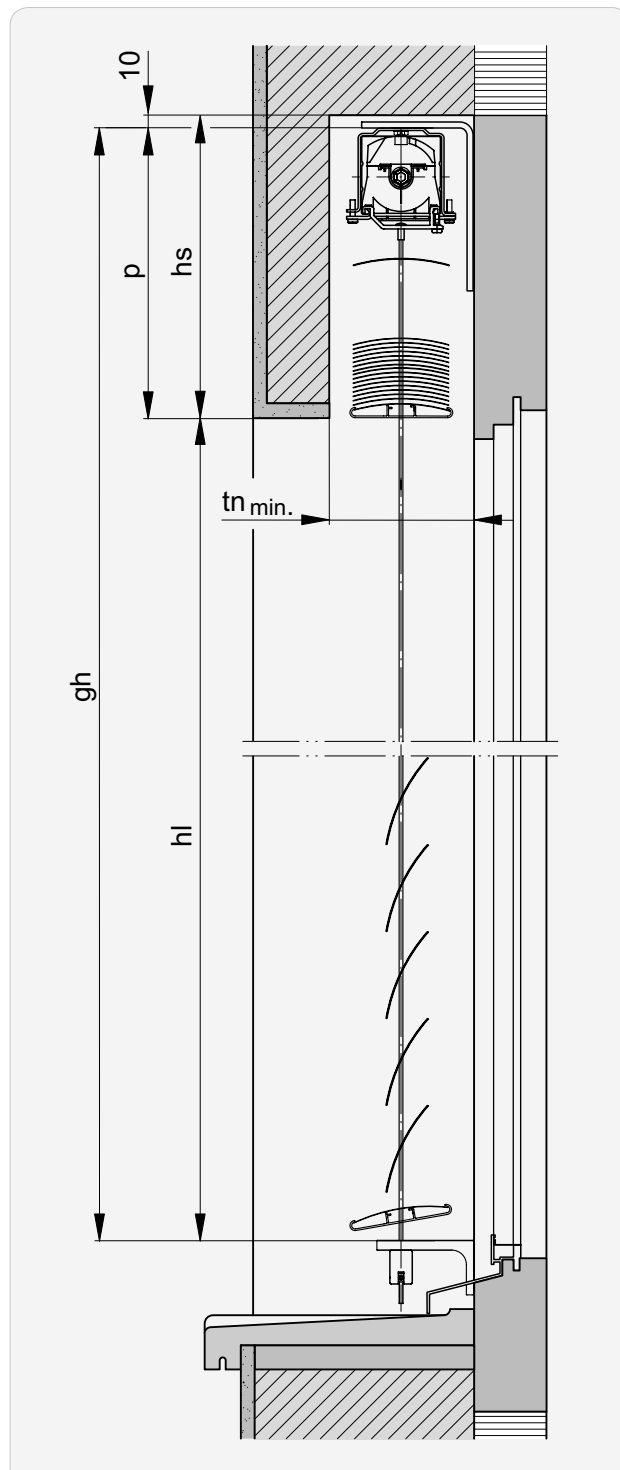

hl, gh at bottom: Top edge of cable fastening

- hs** Header height
- p** Height of package
- tn** Niche depth

►► Definitions of dimensions

Distance between guides FD

For rail guide

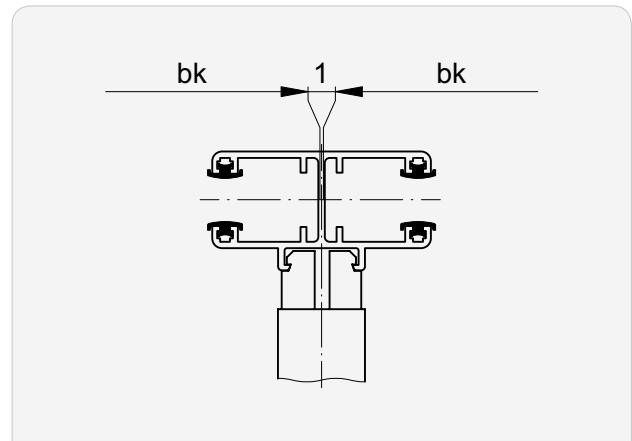
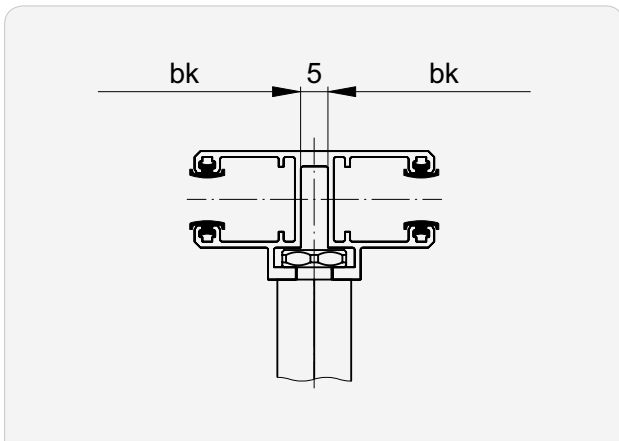
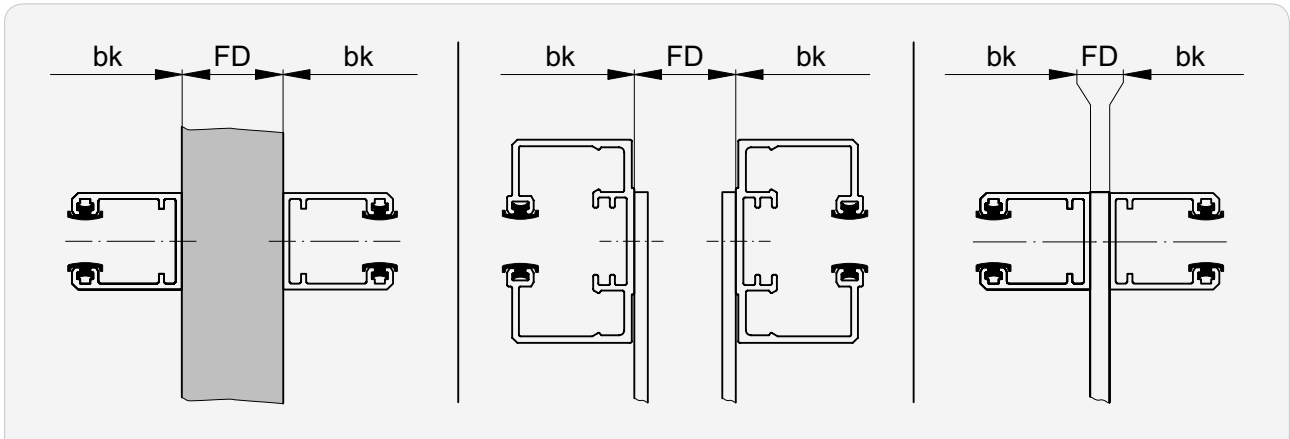

FD Rear edge of guide rails

For cable guide

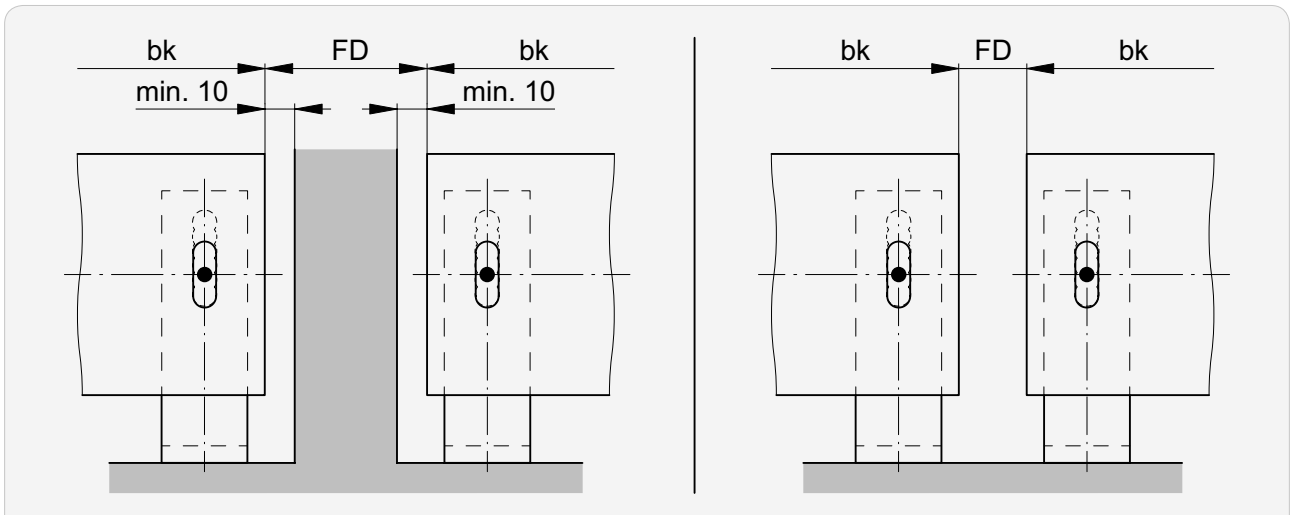

FD Slat end – slat end

For blinds situated directly next to each other:
horizontal distance between the slats at least 15.

Installation base

- 1 Wood
- 2 Stone
- 3 Metal, Aluminum >4 mm, Steel >3 mm
- 4 Sheet metal, Aluminum 2 ... 4 mm, Steel 2 ... 3 mm
- 5 External insulation*
- 6 Plastic
- 7 Chipboard
- 8 Aerated concrete
- 10 Concrete
- 13 Eternit
- 14 Built-in plate
- 15 Sheet metal Al | Cu 2 ... 4 mm
- 16 Insulation EPS 150

* Insulation d: 5 ... 110 mm

Index

A

Additional cables

Aluflex®	
cable guide	230
guide rail	201
Solomatic® II	
cable guide	292
Aluflex®	179
AT	
Aluflex®	189
Grinotex® III Grinotex® III Sinus	39
Lamisol® III	82
Lamisol® III System	127
Lamisol® III Vento	156
Solomatic® II	249
Solomatic® II System	309

BBeginning distance ▶ **AT**

bk (definition)	334
Box base profile	
Aluflex®	193
Solomatic® II	253
Box extensions	
Aluflex®	186
Box fastening	
Aluflex®	193
Solomatic® II	253
Box supports, number of	
Aluflex®	192
Grinotex® III Grinotex® III Sinus	42
Lamisol® III	85
Lamisol® III Vento	159
Solomatic® II	252

C

Cable fastenings

Aluflex®	234
Solomatic® II	298
Cable outlet	
Lamisol® III System	128
Solomatic® II System	310
Connected systems	
Aluflex®	
cable guide	236
guide rail	225
Grinotex® III Grinotex® III Sinus	70

Lamisol® III	117
Metalunic® V Metalunic® V Sinus	28
Solomatic® II	
cable guide	300
guide rail	287
Construction width (definition) ▶ bk (definition)	

D

d-dimension

Aluflex®	197
Grinotex® III Grinotex® III Sinus	45
Lamisol® III	88
Lamisol® III Vento	162
Metalunic® V Metalunic® V Sinus	12
Solomatic® II	257
Darkening	
Grinotex® III	43
Metalunic® V	10
Darkening profile	
Metalunic® V	10
Definitions of dimensions	334
Distance between guides ▶ FD	
Distance between guides (definition) ▶ FD (definition)	
Double lip-seal	
Grinotex® III	43

E

End rails

Aluflex®	188
Grinotex® III Grinotex® III Sinus	38
Lamisol® III	81
Lamisol® III System	126
Lamisol® III Vento	155
Solomatic® II	248
Solomatic® II System	308

F

Fastening points

Aluflex®	221
Grinotex® III Grinotex® III Sinus	65
Lamisol® III	113
Lamisol® III System	141
Lamisol® III Vento	172
Metalunic® V Metalunic® V Sinus	24
Solomatic® II	283
Solomatic® II System	323

FD

Aluflex®	
cable guide	236
guide rail	225
Grinotex® III Grinotex® III Sinus	70
Lamisol® III	117
Metalunic® V Metalunic® V Sinus	28
Solomatic® II	
cable guide	300
guide rail	287
FD (definition)	336
Finished clear height (definition) ▶ hl (definition)	

G

gh (definition)	335
Grinotex® III Grinotex® III Sinus	33
Guide extension	
Aluflex®	215
Grinotex® III Grinotex® III Sinus	59
Lamisol® III	106
Lamisol® III System	139
Lamisol® III Vento	170
Metalunic® V Metalunic® V Sinus	21
Solomatic® II	276
Solomatic® II System	321
Guide facet	
Aluflex®	215
Grinotex® III Grinotex® III Sinus	59
Lamisol® III	106
Lamisol® III System	139
Metalunic® V Metalunic® V Sinus	21
Solomatic® II	276
Solomatic® II System	321
Guide rails	
Aluflex®	196
Grinotex® III Grinotex® III Sinus	44
Lamisol® III	87
Lamisol® III System	129
Lamisol® III Vento	161
Metalunic® V Metalunic® V Sinus	11
Solomatic® II	256
Solomatic® II System	311
Guide rail cut-outs in windowsill area	
Aluflex®	218
Grinotex® III Grinotex® III Sinus	60
Lamisol® III	109
Metalunic® V Metalunic® V Sinus	22
Solomatic® II	279

Guide rail end for suspended guide rails

Aluflex®	219
Lamisol® III	111
Solomatic® II	281
Guide rail fastenings (principle)	
Aluflex®	207
Grinotex® III Grinotex® III Sinus	54
Lamisol® III	98
Lamisol® III System	138
Lamisol® III Vento	167
Metalunic® V Metalunic® V Sinus	16
Solomatic® II	268
Solomatic® II System	320
Guide rail installation (principle)	
Aluflex®	205
Grinotex® III Grinotex® III Sinus	52
Lamisol® III	96
Lamisol® III System	137
Lamisol® III Vento	165
Metalunic® V Metalunic® V Sinus	14
Solomatic® II	266
Solomatic® II System	319

H

Header dimensions

Aluflex®	187
Grinotex® III Grinotex® III Sinus	36 37
Lamisol® III	80
Lamisol® III System	125
Lamisol® III Vento	154
Metalunic® V Metalunic® V Sinus	8
Solomatic® II	247
Solomatic® II System	307

Header height (definition) ▶ **hs (definition)**Height of gearbox recess (definition) ▶ **hg (definition)**Height of package ▶ **Header dimensions**Height of package (definition) ▶ **p (definition)**

hg (definition)	335
hl (definition)	335
Housing fastening	
Aluflex®	190
Grinotex® III Grinotex® III Sinus	40
Lamisol® III	83
Lamisol® III Vento	157
Solomatic® II	250
hs ▶ Header dimensions	
hs (definition)	335

I

Installation base	337
Installation window	
Aluflex®	220
Grinotex® III Grinotex® III Sinus	64
Lamisol® III	112
Lamisol® III Vento	171
Solomatic® II	282

J

Joint-covering profile	
Grinotex® III	43

L

Lamisol® III	75
Lamisol® III System	121
Lamisol® III Vento	151
Limit dimensions	
Aluflex®	180
Grinotex® III Grinotex® III Sinus	34
Lamisol® III	76
Lamisol® III System	122
Lamisol® III Vento	152
Metalunic® V Metalunic® V Sinus	6
Solomatic® II	240
Solomatic® II System	307

M

MBMA	
Aluflex®	
cable guide	229
guide rail	200
Grinotex® III Grinotex® III Sinus	46
Lamisol® III	90
Metalunic® V Metalunic® V Sinus	13
Solomatic® II	
cable guide	291
guide rail	260
Metalunic® V Metalunic® V Sinus	5

O

Opening for connected blinds	
Aluflex®	
cable guide	237
guide rail	226
Grinotex® III Grinotex® III Sinus	71
Lamisol® III	118
Metalunic® V Metalunic® V Sinus	29

Solomatic® II	
cable guide	301
guide rail	288

Overall height (definition) ▶ **gh (definition)****P**

p (definition)	335
Package projection Box	
Aluflex®	186

R

Reflect	
Lamisol® III	86
Lamisol® III Vento	160
Solomatic® II	255

S

SD	
Aluflex®	189
Grinotex® III Grinotex® III Sinus	39
Lamisol® III	82
Lamisol® III System	127
Lamisol® III Vento	156
Solomatic® II	249
Solomatic® II System	309

Sections for crank drive ▶ **MBMA**

Slat profiles	
Aluflex®	188
Grinotex® III Grinotex® III Sinus	38
Lamisol® III	81
Lamisol® III System	126
Lamisol® III Vento	155
Metalunic® V Metalunic® V Sinus	9
Solomatic® II	248
Solomatic® II System	308

Slot spacing ▶ **SD**

Solomatic® II	239
Solomatic® II System	303

Standard motor position

Aluflex®	
cable guide	231
guide rail	202
Grinotex® III Grinotex® III Sinus	47
Lamisol® III	91
Lamisol® III System	132
Lamisol® III Vento	163

Solomatic® II	
cable guide	293
guide rail	261
Solomatic® II System	314
System width (definition)	334

T

Technical data of motors

Aluflex®	194
Grinotex® III Grinotex® III Sinus	72
Lamisol® III	119
Lamisol® III System	149
Lamisol® III Vento	176
Metalunic® V Metalunic® V Sinus	30
Solomatic® II	254
Solomatic® II System	331

tn ▶ **Header dimensions**

tn (definition)	335
-----------------	------------

V

Vertical connections

Aluflex®	
cable guide	231
guide rail	202
Grinotex® III Grinotex® III Sinus	47
Lamisol® III	91
Lamisol® III System	132
Lamisol® III Vento	163
Solomatic® II	
cable guide	293
guide rail	261
Solomatic® II System	314



